

# Model IWS12 with analog or SSI output

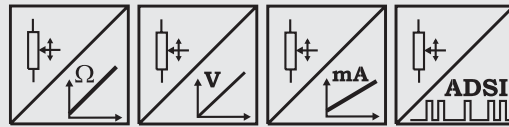

### Sensor for hostile environments

- Protection class IP67
- Measurement ranges: 0 ... 100 mm to 0 ... 3000 mm
- Analog output 0 ... 10 V, 4 ... 20 mA, potentiometer or A/D converted synchronous serial output (SSI)



<b>Specifications</b>	Outputs	Potentiometer: 1 kΩ Voltage: 0...10 V Current: 4...20 mA, 2 or 3 wire Voltage and current output, adjustable A/D converted synchronous serial max. 16 bit (SSI)
	Resolution	Essentially infinite / ADSI16: max. 16 bit full scale
	Material	Aluminium and stainless steel. Cable: stainless steel
	Sensing device	Precision potentiometer
	Connector	Male socket 8 pin (M12 or DIN 45326)
	Linearity	Up to ±0.05 % full scale
	Protection class	IP67 (only when the electrical plug is correctly assembled and connected)
	Weight (approx.)	≤1500 mm: 1 kg; ≥2000 mm: 1.5 kg
	Environmental	
		EMC
	Temperature	Refer to output specification

**Order Code WS12**

**Analog**

**Model Name** WS12 - [ ] - [ ] - [ ] - [ ] - [ ]

**Measurement Range (in mm)**  
100 / 125 / 375 / 500 / 750 / 1000 / 1250 / 1500 / 2000 / 2500 / 3000

**Outputs** (see pages 57 ff.)

R1K = Potentiometer 1 kΩ (other values on request)  
 10V = with 0 ... 10 V Signal Conditioner  
 420A = with 4 ... 20 mA Signal Conditioner (2 wire)  
 420T = with 4 ... 20 mA Signal Conditioner (3 wire)  
 PMU = with 0...10/4...20 mA Signal Conditioner, adjustable  
 ADSI16 = with A/D converted synchronous serial output 16 bit (option: 12, 14 bit)

**Linearity**  
 L10 = ±0.10 %    option:    L05 = ±0,05 %    L25 = ±0.25 %

**Cable fixing**  
 M4 = M4 cable fixing  
 SB0 = Cable clip

**Connection**  
 M12 = 8 pin socket M12  
 D8 = 8 pin socket DIN 45326

Order Code Mating Connector (see accessories p. 82) D8: **CONN-DIN-8F-W** M12: **CONN-M12-8F-G**

**Order Example: WS12 - 2500 - 10V - L10 - M4 - M12**

# Model IWS12 with analog or SSI output

Cable Forces typical at 20 °C	Range	Maximum Pull-out Force	Minimum Pull-in Force
	[mm]	[N]	[N]
	100	5.2	2.8
	125	4.6	2.5
	375	7.5	3.7
	500	5.9	2.6
	750	7.5	3.3
	100	5.5	2.4
	1250	4.8	2.1
	1500	10.4	6.4
	2000	8.1	5.0
	2500	6.7	4.0
	3000	6.2	3.0

## Outline drawing

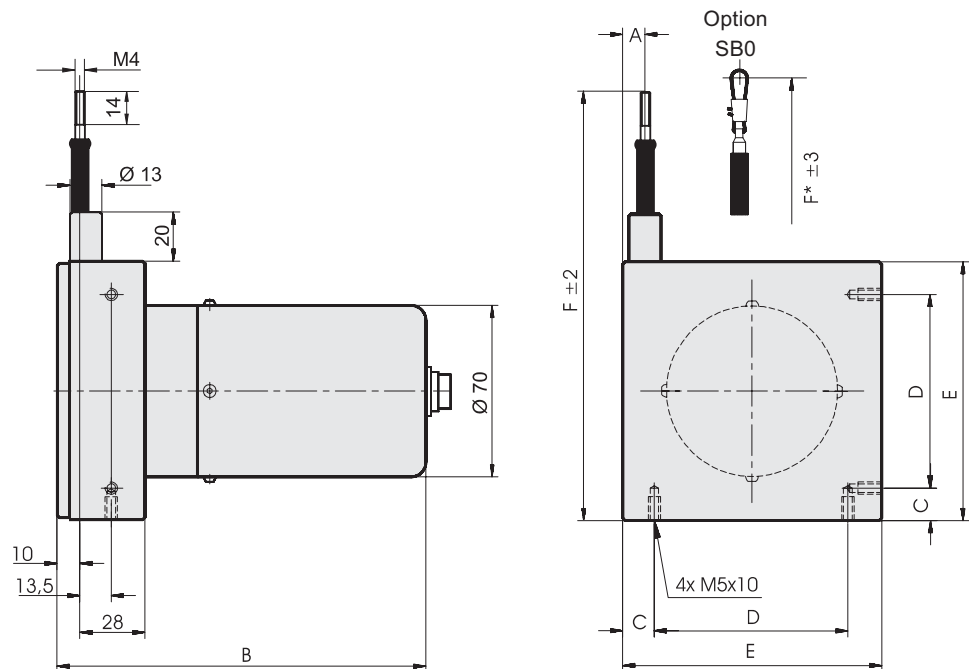

Dimensions informative only.  
For guaranteed dimensions consult factory

Dimensions	Range	A	B (ADSI16)	C...E	F (F*)
	[mm]				
	100; 500; 1000	18,5	112 (137)	C=14, D=43, E=71	141 (149)
	125; 1250	15,0	112 (137)		
	1500	11,0	127 (152)		
	2000	22,0	127 (152)	C=15, D=79, E=109, F=182±3	179 (187)
	2500	13,5	127 (152)		
	3000	9,5	127 (152)		

# Model IWS12 with incremental encoder output



## Sensor for hostile environments

- Protection class IP67
- Measurement ranges:  
0 ... 1250 mm to 0 ... 3000 mm
- Incremental encoder output



Specifications	Outputs	Incremental encoder output for reliable data transmission. The output is compatible with TTL and HTL.
Resolution	5 or 10 pulses per mm (1/40 mm with external edge counting mode)	
Material	Aluminium and stainless steel. Cable: stainless steel	
Sensing device	Incremental encoder	
Connector	Male socket 8 pin (M12 or DIN 45326)	
Linearity	±0.05 % full scale	
Protection Class	IP67 (only when the electrical plug is correctly assembled and connected)	
Weight	Up to 1500 mm: 1 kg approx. 2000 mm and greater: 1.5 kg approx.	
Environmental		
EMC	Refer to output specification	
Temperature	Refer to output specification	

## Order Code IWS12 Incremental

Model Name	IWS12 - [ ] - [ ] - [ ] - [ ] - [ ]
<b>Measurement Range (in mm)</b>	1250 (all smaller ranges included) / 1500 / 2000 / 2500 / 3000
<b>Pulses per mm</b>	10 = 10 Pulses per mm (1250, 1500 mm) 5 = 5 Pulses per mm (2000, 2500, 3000 mm) Other numbers of pulses on request
<b>Output</b> (see page 60)	IE24LI = Incremental output TTL compatible inverted (up to 1250 mm range only) IE24HI = Incremental output HTL compatible inverted (up to 1250 mm range only) PP530 = Incremental output TTL and HTL compatible
<b>Cable fixing</b>	M4 = M4 cable fixing SB0 = cable clip
<b>Connection</b>	M12 = 8 pin socket M12 D8 = 8 pin socket DIN 45326

Order Code Mating Connector (see accessories p. 82) D8: **CONN-DIN-8F-W** M12: **CONN-M12-8F-G**

Order Example: IWS12 - 1500 - 10 - PP530 - M4 - M12

# Model IWS12 with incremental encoder output

Cable Forces typical at 20 °C	Range [mm]	Max. Pull-out Force [N]	Min. Pull-in Force [N]
	1250	6.6	2.7
	1500	10.6	6.5
	2000	5.7	4.1
	2500	5.7	4.1
	3000	5.8	4.0

## Outline drawing

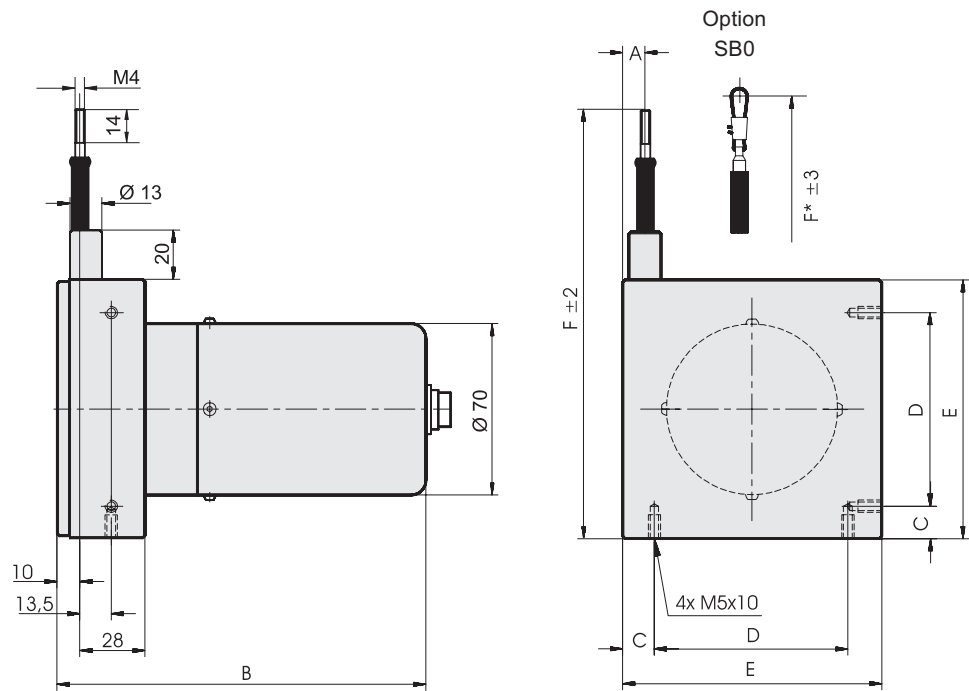

Dimensions informative only.  
For guaranteed dimensions consult factory

Dimensions	Range [mm]	A	B	C	D	E	F (F*)
	1250	18,5	137	14	43	71	141 (149)
	1500	11	152	14	43	71	141 (149)
	2000	9,5	152	15	79	109	179 (187)
	2500	9,5	152	15	79	109	179 (187)
	3000	9,5	152	15	79	109	179 (187)

# Output Specifications

## R1K and 10V for IWS position sensors

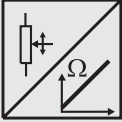
<b>Voltage divider R1K</b> Potentiometer 	Excitation Voltage	32 VDC max. at 1 kΩ (input power 1 W max.)
	Potentiometer Impedance	1 kΩ ±10%
	Thermal coefficient	±25 x 10 <sup>-6</sup> / °C full scale
	Sensitivity	Depends on measurement range, individual sensitivity of sensor specified on label
	Voltage Divider Utilization Range	Approx. 3% ... 97% of full range
	Operating Temperature	-20 ... +85 °C

### Signal diagram

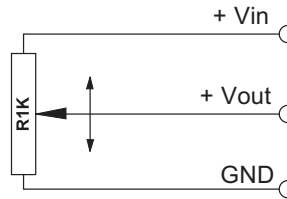

Note: The potentiometer must be connected as a voltage divider. The input impedance of the following processing circuit should be 10 MΩ min.

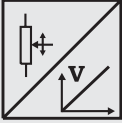
<b>Signal conditioner 10V</b> Voltage output 	Excitation Voltage	+18 ... +27 V DC non stabilized
	Excitation Current	20 mA max.
	Output Voltage	0 ... +10 V DC
	Output Current	2 mA max.
	Output Load	> 5 kΩ
	Stability (Temperature)	±50 x 10 <sup>-6</sup> / °C full scale
	Protection	Reverse polarity, short circuit
	Output Noise	0,5 mV <sub>RMS</sub>
	Operating Temperature	-20 ... +85 °C
	EMC	According to EN 61326:2004

### Signal diagram

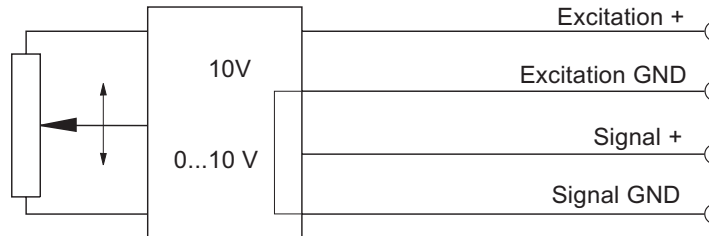

Signal Wiring	Output signals		Cable color	Connector pin no.
	R1K	10V		
+ Vin		Excitation +	White	1
GND		Excitation GND	Brown	2
+ Vout		Signal +	Green	3
		Signal GND	Yellow	4

### Connection

#### Mating Connector

View to solder terminals

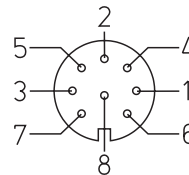

CONN-DIN-8F-W

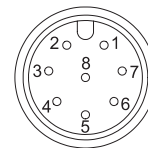

CONN-M12-8F-G

# Output Specifications

## 420A and 420T for IWS position sensors

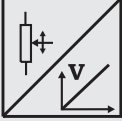
<b>Signal conditioner</b> <b>420A</b> Current output (2 wire) 	Excitation Voltage	+12 ... 27 VDC non stabilized, measured at the sensor terminals
	Excitation Current	35 mA max.
	Output Current	4 ... 20 mA equivalent to 0 ... 100% range
	Stability (Temperature)	$\pm 100 \times 10^{-6} / ^\circ\text{C}$ full scale
	Protection	Reverse polarity, short circuit
	Output Noise	0.5 mV <sub>RMS</sub>
	Operating Temperature	-20 ... +85 °C
	EMC	According to EN 61326:2004

### Signal Diagram

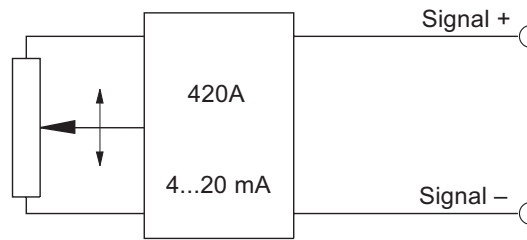

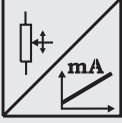
<b>Signal Conditioner</b> <b>420T</b> Current output (3 wire) 	Excitation Voltage	+18...+27 V DC non stabilized
	Excitation Current	40 mA max.
	Load Resistor	350 Ω max.
	Output Current	4 ... 20 mA equivalent to 0 ... 100% range
	Stability (Temperature)	$\pm 50 \times 10^{-6} / ^\circ\text{C}$ full scale
	Protection	Reverse polarity, short circuit
	Output Noise	0.5 mV <sub>RMS</sub>
	Operating Temperature	-20 ... +85 °C
	EMC	According to EN 61326:2004

### Signal diagram

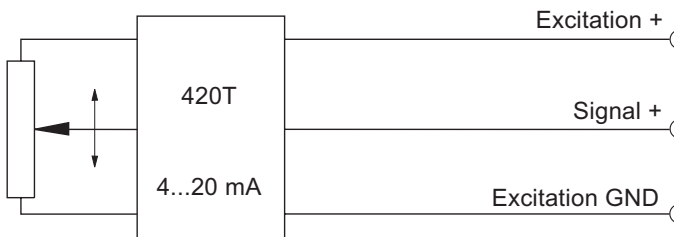

Signal Wiring	Output signals		Cable color	Connector pin no.
	420A	420T		
Signal +		Excitation +	White	1
Signal -		Excitation GND	Brown	2
		Signal +	Green	3

### Connection

Mating Connector

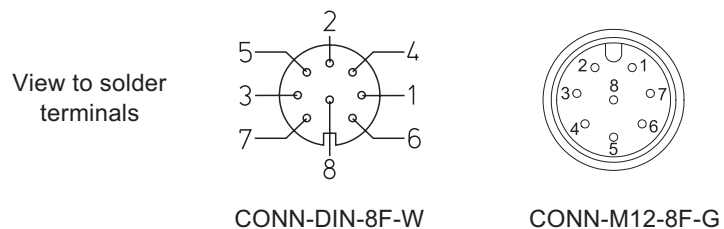

# Output Specification

## PMU for IWS position sensors

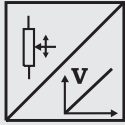
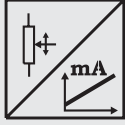
<b>Signal Conditioner PMU, adjustable</b> Voltage output and current output (3 wire)  	Excitation voltage	+18 ... 27 V DC
	Excitation current	50 mA max.
	Voltage output	0 ... 10 V
	Output current	10 mA max.
	Output load	1 kΩ min.
	Current output	4 ... 20 mA (3 wire)
	Load resistor	500 Ω max.
	Adjustment	
	Activation of offset and gain adjust	Connect with excitation GND (0 V)
	Scalable range	90 % max. full scale
	Stability (Temperature)	$\pm 50 \times 10^{-6}$ / °C full scale
	Protection	Reverse polarity, short circuit
	Output noise	1 mV <sub>eff</sub>
Operating temperature	-20 ... +85 °C	
EMC	According to EN 61326:2004	

### Signal diagram

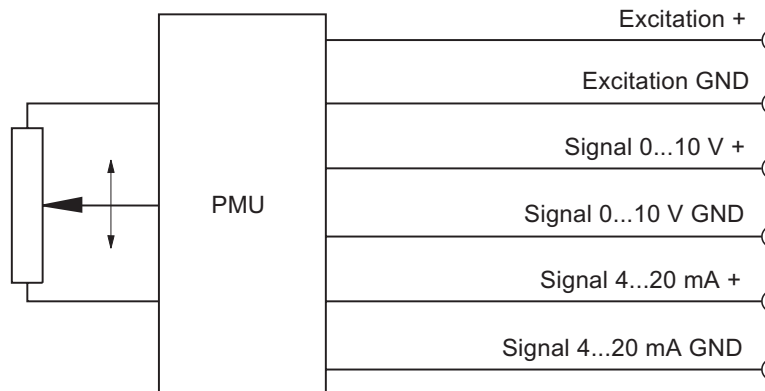

Signal wiring	Output signals	Connector pin no.
	Excitation +	1
	Excitation GND	2
	Signal 0...10 V +	3
	Signal 0...10 V GND	4
	Signal 4...20 mA +	5
	Signal 4...20 mA GND	6
	Offset	7
	Gain	8

### Connection

Mating Connector

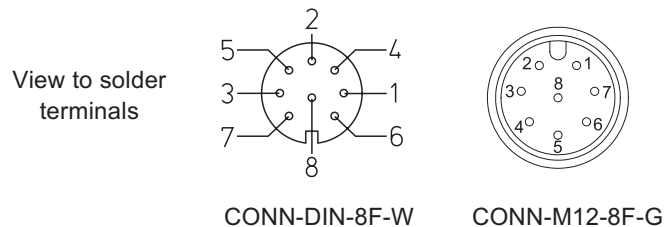

# Output Specification

## ADSI16 for IWS position sensors

- Resolution 16 bit, data transmission synchronous serial/SSI
- Optional available with 12 bit (ADSI) or 14 bit (ADSI14) resolution
- No loss of data at power-down
- Easy to connect to PLC's with SSI input circuit

### Description

The sensing device of the ADSI is a precision potentiometer. The position information is given by an analog/digital converter output serialized as a data word. Data transmission takes place by means of the signals CLOCK and DATA. The processing unit (PLC, Micro-computer) sends pulse sequences which clock the data transmission with the required transfer rate. With the first falling edge of a pulse sequence the position of the sensor is recorded and stored. The following rising edges control the bit-by-bit A/D conversion, encoding and output of the data word. After a delay time the next new position information will be transmitted.

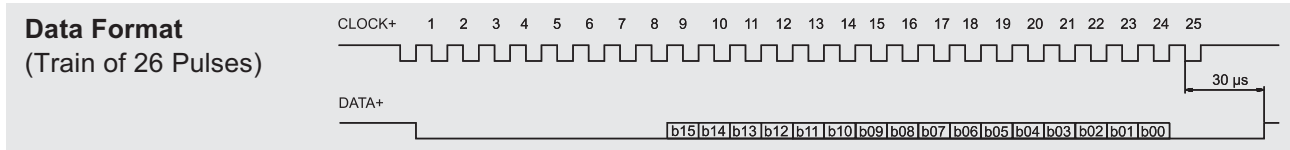

<b>Signal Conditioner</b> <b>ADSI</b> A/D converted synchronous serial 	Output	EIA RS-422, RS-485, short-circuit proof
	Excitation voltage	11 ... 27 VDC
	Excitation current	200 mA max.
	Clock frequency	70 ... 500 kHz
	Code	Gray code, continuous progression
	Delay between pulse trains	T=30 µs min.
	Resolution	16 bit (65536 counts) full scale; optional 12 bit or 14 bit
	Stability (temperature)	±50 x 10 <sup>-6</sup> / °C full scale
	Operation temperature	-20 ... +85 °C
	EMC	According to EN 61326:2004

### Recommended Processing Input Circuit

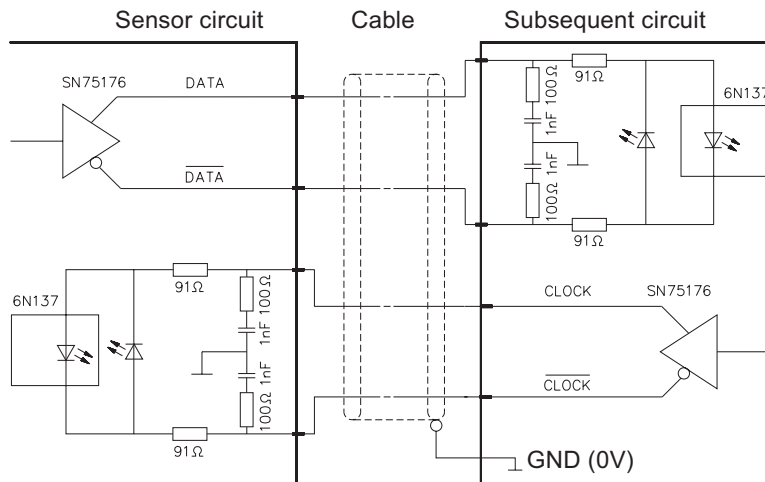

<b>Transmission rate</b>	<b>Cable length</b>	<b>Baud rate</b>
	< 50 m	< 300 kHz
	< 100 m	< 100 kHz

### Note:

Extension of the cable length will reduce the maximum transmission rate. The signals CLOCK/CLOCK and DATA/DATA must be connected in a twisted pair cable, shielded per pair and common.

<b>Signal Wiring</b>	<b>Signal names</b>	<b>Connector pin no.</b>
	Excitation +	1
	Excitation GND (0V)	2
	CLOCK	3
	CLOCK	4
	DATA	5
	DATA	6
Screen	not connected	

Mating connector: view to solder terminals

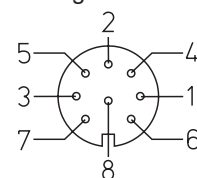

CONN-DIN-8F-W

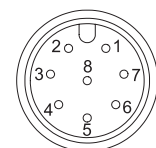

CONN-M12-8F-G



# Output Specifications

## IE24LI and IE24HI for IWS position sensors

IE24LI and IE24HI incremental	IE24LI		IE24HI
	Excitation voltage	5 V DC $\pm 10\%$	
Excitation current	100 mA max.		
Output frequency	200 kHz		
Output	Push-pull and inverted signals		
Output current	10 mA max.		
Output voltage	Depending on the excitation voltage		
Stability (temperature)	$\pm 20 \times 10^{-6} / ^\circ\text{C}$ f.s. (sensor mechanism)		
Operation temperature	-20 ... +85 $^\circ\text{C}$		
Protection	Short circuit		
EMC	According to EN 61326:2004		

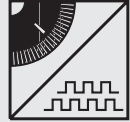

### Output signals

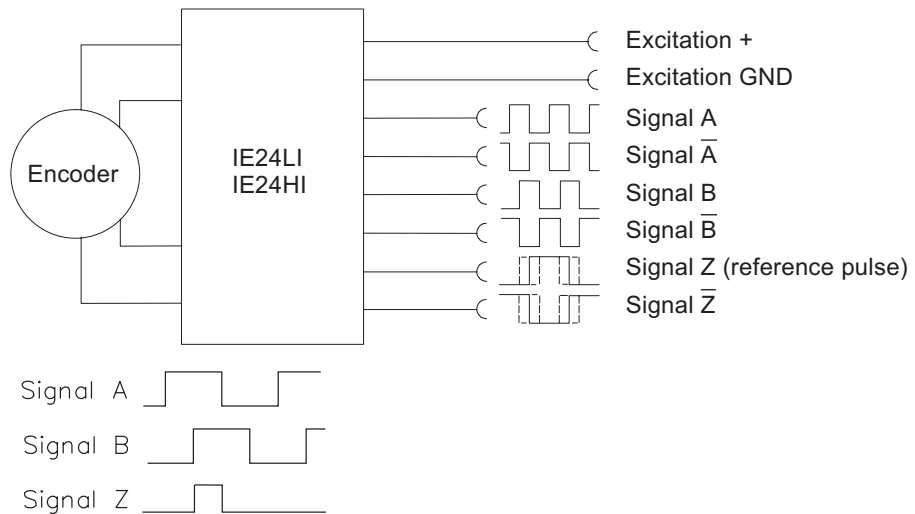

### Output circuit and recommended processing input circuit

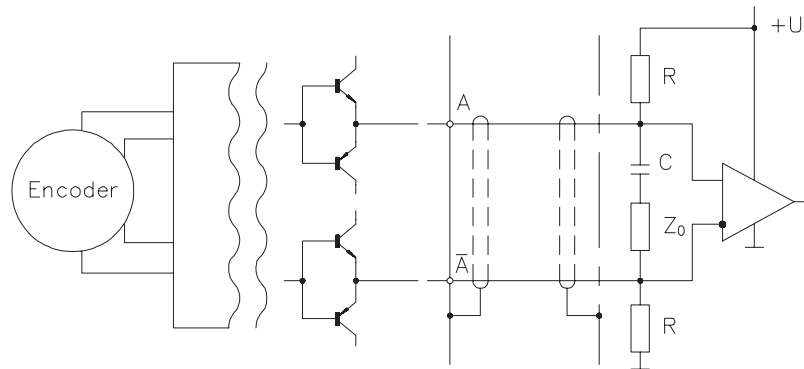

Signal wiring	Output signals	Cable color	Connector pin no.
	Excitation +	Brown	1
	Excitation GND	White	2
	Signal B (A + 90°)	Grey	3
	Signal A	Green	4
	Signal B-bar	Pink	5
	Signal A-bar	Yellow	6
	Signal Z (reference pulse)	Blue	7
	Signal Z-bar	Red	8

### Connection

Mating connector

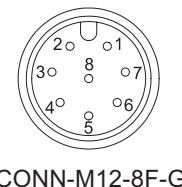
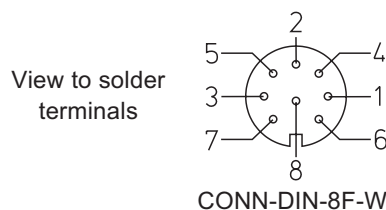

# Output Specification PP530 for IWS position sensors

<b>Signal Conditioner PP530</b> Incremental 	Excitation Voltage	+5 ... +30 VDC
	Excitation Current	200 mA max.
	Output Frequency	200 kHz max.
	Output	Linedriver, Push-Pull, CMOS, TTL and HTL compatible
	Output Current	30 mA max., short circuit protection
	Output Voltage	Depends on the excitation voltage (e.g. to obtain TTL-signals the excitation must be 5 V.) Compatible to EIA RS-422/RS-485
	Stability (Temperature)	$\pm 20 \times 10^{-6}$ / K full scale (sensor mechanism)
	Operation Temperature	-10 ... +70 °C
	Storage Temperature	-30 ... +80 °C
	Transition Time Positive Edge	250 ns
	Transition Time Negative Edge	250 ns
	Protection	Reverse polarity, short circuit
	EMC	According to EN61326:2004

## Signal Diagram

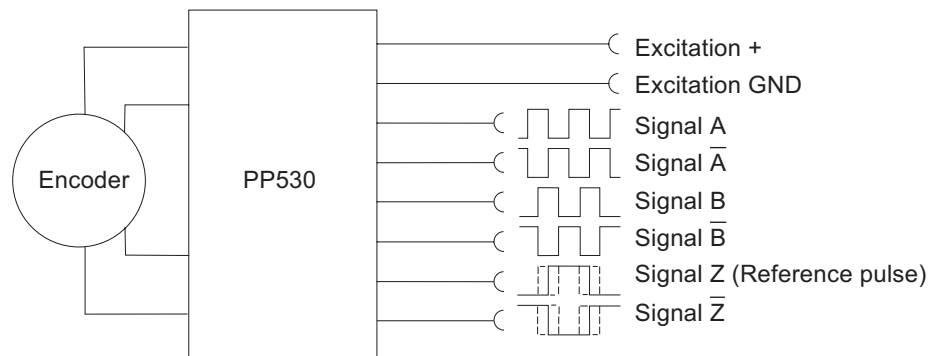

## Recommended Processing Circuit

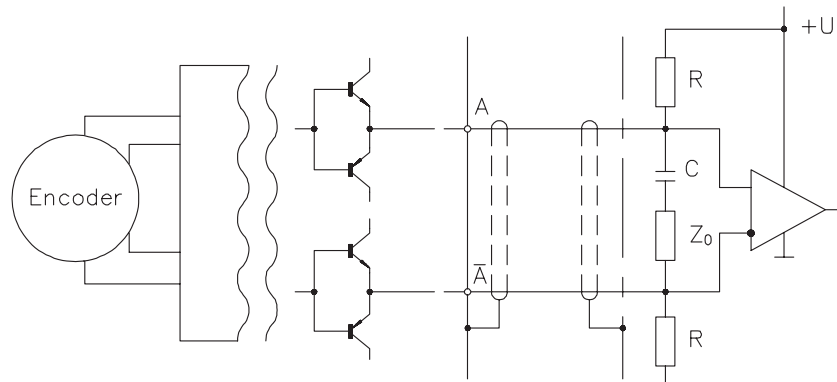

Signal Levels	Excitation	Level	$I_a \leq 5 \text{ mA}$	$I_a \leq 25 \text{ mA}$	$-I_a \leq 5 \text{ mA}$	$-I_a \leq 25 \text{ mA}$
	5 V	$U_{aHigh}$	$>4.2 \text{ V}$	$>4.2 \text{ V}$	$>4.1 \text{ V}$	$>3.8 \text{ V}$
5 V	$U_{aLow}$	$<0.5 \text{ V}$	$<1.2 \text{ V}$	$<0.4 \text{ V}$	$<0.4 \text{ V}$	
24 V	$U_{aHigh}$	$>23.5 \text{ V}$	$>23.5 \text{ V}$	$>23.5 \text{ V}$	$>22.5 \text{ V}$	
24 V	$U_{aLow}$	$<0.5 \text{ V}$	$<1.2 \text{ V}$	$<0.4 \text{ V}$	$<0.4 \text{ V}$	

Signal Wiring / Connection	Output signals	Connector CONN-DIN-8F
	Excitation +	1
Excitation GND (0V)	2	
Signal B (A + 90°)	3	
Signal A	4	
Signal B-bar	5	
Signal A-bar	6	
Signal Z (reference pulse)	7	
Signal Z-bar	8	

Mating connector  
View to solder terminals

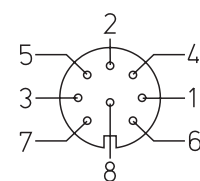

CONN-DIN-8F-W