

Pressure switch, high adjustability of switch differential For the process industry Model PSM-700, with robust aluminium case



for further approvals see
page 3

Applications

- Pumps for process applications (e.g. water treatment, water supply and distribution)
- Industrial hydraulics (e.g. pressure control, oil pressure monitoring and overpressure protection in process lines)
- Discharge control for automatic sprinkler systems
- Compressor controls in pneumatic applications

Special features

- Switch differential adjustable within a wide range of up to 60 % of the setting range to realise flexible on/off controls
- Robust aluminium case
- Switch point repeatability of $\leq 0.5\%$ for reliable switching
- High-quality micro switches with long service life
- Up to 2 possible positions for electrical connection



Fig. left: With adjustable switch differential
Fig. right: With fixed switch differential

Description

The model PSM-700 mechanical pressure switch has been designed for control and monitoring applications. The measuring element is a fully welded bellow made of stainless steel 316L. This corrosion-resistant pressure switch is suitable for a broad range of media used in the process industry.

The case consists of a high-grade aluminium alloy with which the pressure switch can withstand the harsh operating conditions of the process industry.

The model PSM-700 is equipped with UL listed micro switches to ensure high endurance with durable operation and long service life.

The model PSM-700 has a high switch point repeatability of $\leq 0.5\%$, which enables reliable switching. Adjustable switch differential to a wide range of up to 60 % of the setting range to realise flexible on/off controls. This wide setting range is often needed for the on/off control mode of cyclic applications.

The switch point can be specified on site. With the available tamper proofing, unauthorised adjustment of the switch point can be prevented.

Specifications

Design

BS 6134:1991

Case

Aluminium (EN AC-44100)

Sealing: EPDM

With blow-out device on the left side

Tamper proofing (option)

Prevents unauthorised adjustment of the switch point.

Ingress protection per IEC/EN 60529

IP66

Permissible temperature ranges

Ambient: -10 ... +60 °C [+14 ... +140 °F]

Medium: ■ -30 ... +115 °C [-22 ... +239 °F]

■ -30 ... +150 °C [-22 ... +302 °F] ¹⁾

Storage: -50 ... +60 °C [-58 ... +140 °F]

Switching function

■ 1 x SPDT (single pole double throw)

■ 1 x DPDT (double pole double throw)

1 or 2 micro switches, contacts silver-plated

The DPDT function is realised with 2 simultaneously triggering SPDT micro switches within 2 % of the setting range.

Switch differential

■ Fixed

■ Adjustable up to 60% of the setting range

The exact value/value range of the switch differential is dependent on the above-selected version and the setting range (see table "Setting range" on page 3)

Switch point repeatability

≤ 0.5 % of span

Switch point setting

■ Factory default setting (see table "setting range" on page 3)

■ Factory-set to customer specification. The switch point and the switching direction need to be specified (e.g. switch point: 5 bar, rising).

Subsequent setting of the switch point on site is made using the adjustment screw, which is fastened to the switch. For optimal performance we suggest to adjust the switch point between 15 % and 70 % of the setting range.

¹⁾ only selectable for contact version: F2, A1, A2

Electrical connection

■ 1 x on the left side for 1 x SPDT version

■ 1 x on the left side and 1 x from above for 1 x DPDT version or 1 x SPDT version (option)

Thread of electrical connection

■ ½ NPT female

■ M20 x 1.5 female

■ ¾ NPT via adapter

Cable gland

■ Without

■ Polyamide

■ Stainless steel

Cable connection using internal terminal block, protective conductor connection using internal and external screw. Maximum grounding cable cross-section 4 mm²

Electrical safety

Safety class I per IEC 61010-1:2010 (case grounded with protective conductor), overvoltage category II, pollution degree 2

Measuring element

Bellow, stainless steel 316L

Process connection

316L stainless steel, lower mount

■ ¼ NPT female per ANSI B1.20.1

■ G ½ male per ISO 228/1

■ G ¼ male per ISO 228/1

Mounting

■ Direct mounting

■ Panel mounting

■ Mounting fixture for wall mounting from stainless steel

■ Mounting bracket for 2" pipe mounting and U-bolts from stainless steel

Weight

Approx. 1.0 ... 1.5 kg, depending on setting range

Process connection

Thread per ANSI B1.20.1

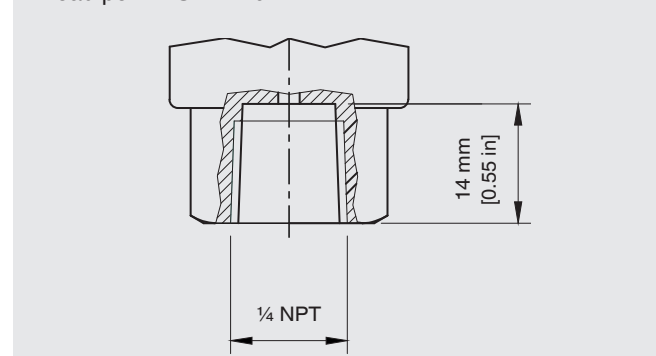

Contact version

Code	Switch differential	Switch type	Electrical rating AC				Electrical rating DC					
			Resistive load		Inductive load		Resistive load			Inductive load		
			125 V	250 V	125 V	250 V	30 V	125 V	250 V	30 V	125 V	250 V
F1	Fixed	SPDT	10 A	10 A	10 A	10 A	2 A	0.4 A	0.2 A	1 A	0.03 A	0.02 A
F2		DPDT	-	15 A	-	10 A	10 A	0.6 A	0.3 A	10 A	0.6 A	0.3 A
A1	Adjustable	SPDT	-	15 A	-	10 A	10 A	0.6 A	0.3 A	10 A	0.6 A	0.3 A
A2		DPDT	-	15 A	-	10 A	10 A	0.6 A	0.3 A	10 A	0.6 A	0.3 A

Setting range

Unit	Setting range	Switch point with factory default setting ¹⁾	Maximum operating pressure	Proof pressure ²⁾	Fixed switch differential ³⁾ SPDT	Fixed switch differential ³⁾ DPDT	Adjustable switch differential ³⁾
bar	-1 ... 1.5 ⁴⁾	0.25	5	20	≤ 0.1	≤ 0.23	0.23 ... 0.9
	0.2 ... 1.6	0.9	2.5	10	≤ 0.06	≤ 0.24	0.24 ... 0.95
	0.4 ... 4	2.2	9	36	≤ 0.16	≤ 0.6	0.6 ... 2.4
	0.7 ... 7	3.85	18	72	≤ 0.28	≤ 1.1	1.1 ... 4
	1 ... 10	5.5	18	72	≤ 0.4	≤ 1.5	1.5 ... 6
	1.6 ... 16	8.8	25	100	≤ 0.64	≤ 2.4	2.5 ... 9.5
	4 ... 25	14.5	36	144	≤ 1	≤ 3.75	3.8 ... 15
	7 ... 35	21	50	200	≤ 1.4	≤ 5.25	5.5 ... 20
psi	-15 ... 21 ⁴⁾	3	72	288	≤ 1.45	≤ 3.3	3.3 ... 13
	3 ... 23	13	36	144	≤ 0.95	≤ 3.5	3.5 ... 13.5
	5.8 ... 58	32	130	520	≤ 2.4	≤ 8.7	8.7 ... 34
	10 ... 100	55	260	1,040	≤ 4.1	≤ 15.5	15.5 ... 60
	15 ... 145	80	260	1,040	≤ 5.1	≤ 22	22 ... 85
	23 ... 230	126.5	360	1,440	≤ 9.5	≤ 35	35 ... 139
	60 ... 360	210	520	2,080	≤ 14.5	≤ 54.5	55 ... 215
	100 ... 500	300	720	2,880	≤ 20.5	≤ 76.5	76.5 ... 300



1) In the absence of customer specification, the switch point will be preset on falling pressure to the specified value

2) Maximum pressure that the sensor element can withstand without suffering any permanent damage. The instrument might have to be calibrated afterwards.

3) The difference between the switch point and the reset point is also known as switch hysteresis

4) Only available with process connection ¼ NPT female

Approvals

Logo	Description	Country
	EU declaration of conformity ■ Low voltage directive ■ RoHS directive	European Union
	EAC (option) Low voltage directive	Eurasian Economic Community

Certificates (option)

- 2.2 test report per EN 10204
- 3.1 inspection certificate per EN 10204

Approvals and certificates, see website

Dimensions in mm [in]

Model PSM-700, fixed switch differential

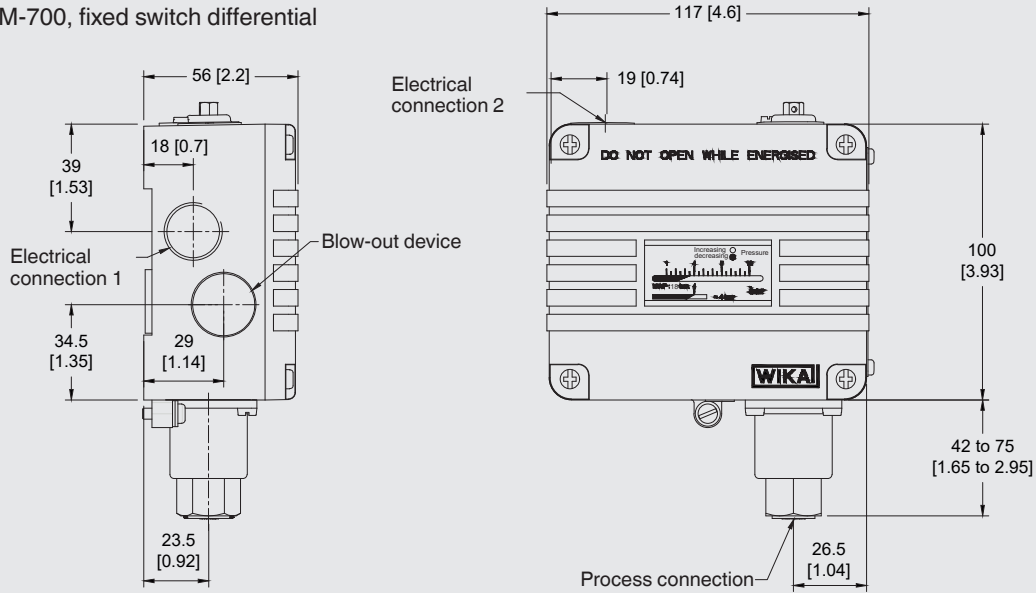

Model PSM-700, adjustable switch differential

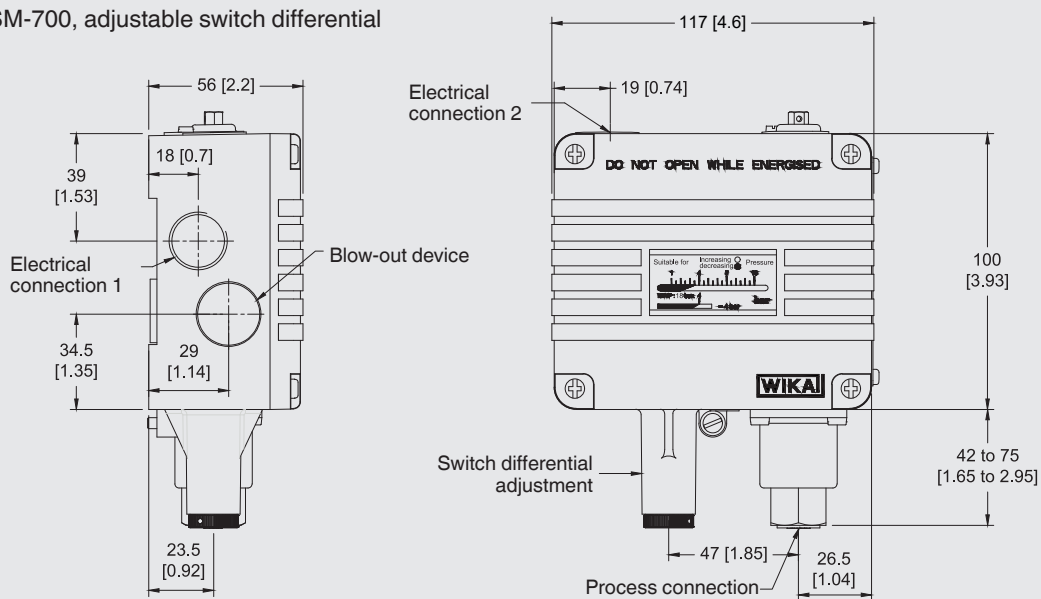

For panel mounting

2 x through bores, suitable for M4 screws, accessible after removal of the case cover

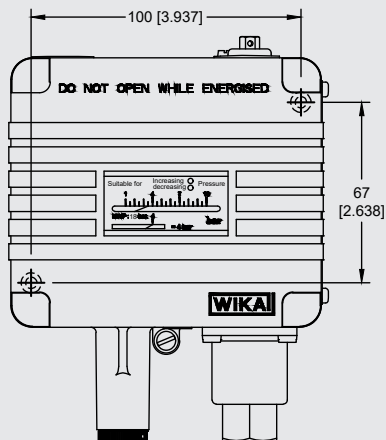

Mounting

Direct mounting

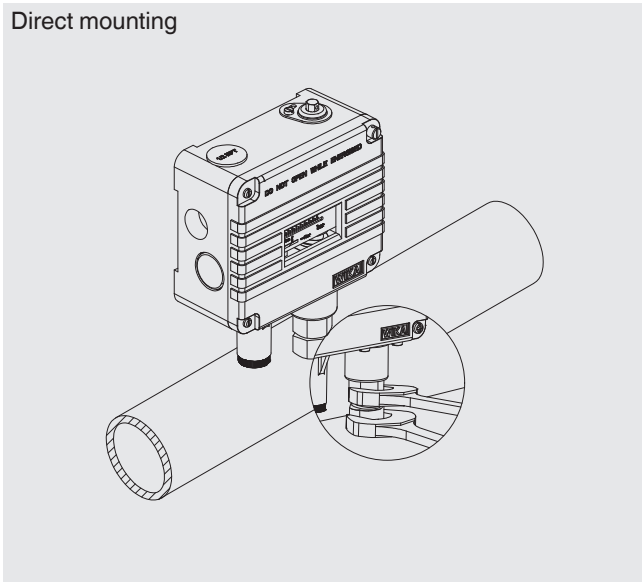

Panel mounting

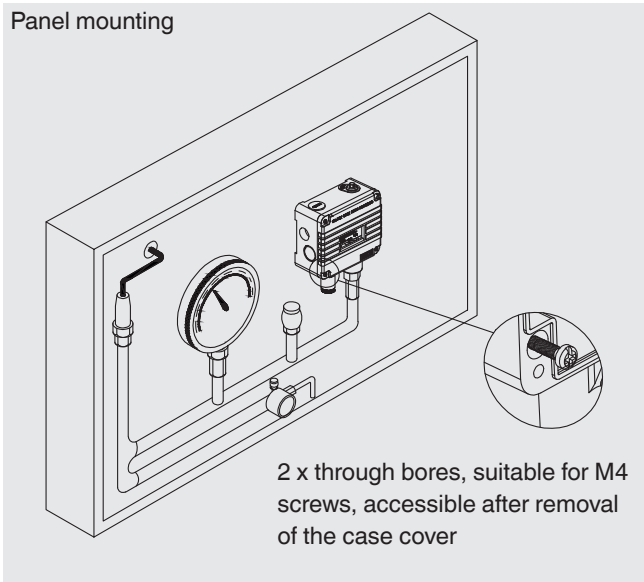

Wall mounting

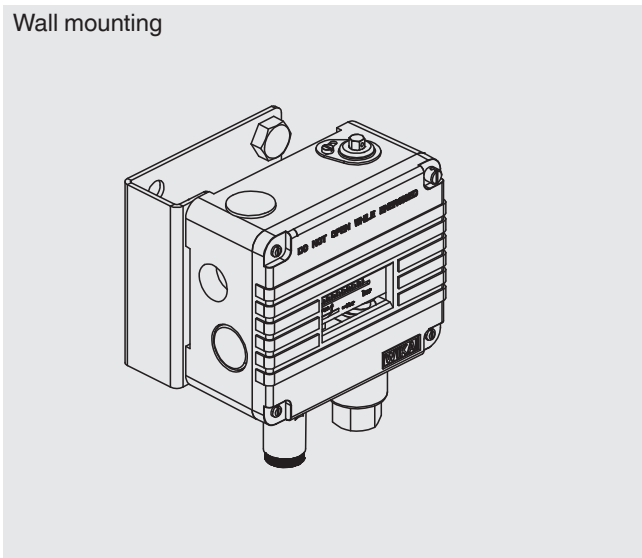

2" pipe mounting

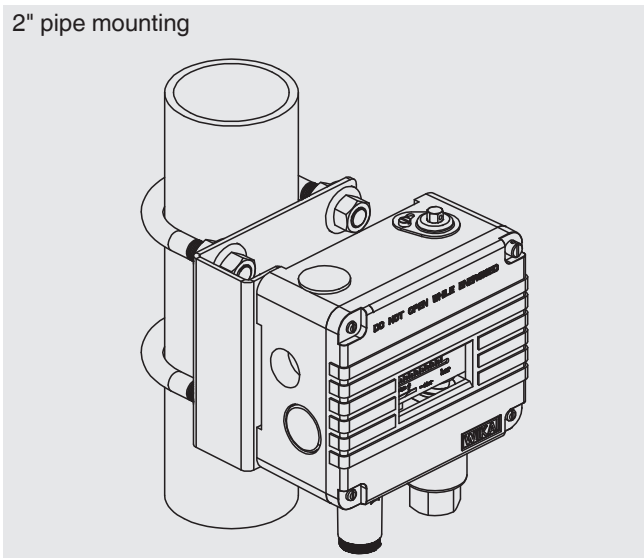

Ordering information

Model / Contact version / Electrical connection / Setting range / Switch point setting

© 01/2019 WIKA Alexander Wiegand SE & Co. KG, all rights reserved.
The specifications given in this document represent the state of engineering at the time of publishing.
We reserve the right to make modifications to the specifications and materials.