



**Transmitter
SITRANS P300**
with HART communication

pressure
measurement

SIEMENS

Pressure measurement technology

Transmitter SITRANS P300 with HART communication

Operating Instructions

| | |
|---------------------------------------|-----------|
| <u>Introduction</u> | 1 |
| <u>General safety instructions</u> | 2 |
| <u>Description</u> | 3 |
| <u>Installation</u> | 4 |
| <u>Connecting</u> | 5 |
| <u>Operation</u> | 6 |
| <u>Operating functions via HART</u> | 7 |
| <u>Commissioning</u> | 8 |
| <u>Specifications</u> | 9 |
| <u>Dimension drawings</u> | 10 |
| <u>Appendix</u> | A |
| <u>List of Abbreviations/Acronyms</u> | B |

Safety Guidelines

This manual contains notices you have to observe in order to ensure your personal safety, as well as to prevent damage to property. The notices referring to your personal safety are highlighted in the manual by a safety alert symbol, notices referring to property damage only have no safety alert symbol. These notices shown below are graded according to the degree of danger.



Danger

indicates that death or severe personal injury **will** result if proper precautions are not taken.



Warning

indicates that death or severe personal injury **may** result if proper precautions are not taken.



Caution

with a safety alert symbol, indicates that minor personal injury can result if proper precautions are not taken.

Caution

without a safety alert symbol, indicates that property damage can result if proper precautions are not taken.

Notice

indicates that an unintended result or situation can occur if the corresponding information is not taken into account.

If more than one degree of danger is present, the warning notice representing the highest degree of danger will be used. A notice warning of injury to persons with a safety alert symbol may also include a warning relating to property damage.

Qualified Personnel

The device/system may only be set up and used in conjunction with this documentation. Commissioning and operation of a device/system may only be performed by **qualified personnel**. Within the context of the safety notes in this documentation qualified persons are defined as persons who are authorized to commission, ground and label devices, systems and circuits in accordance with established safety practices and standards.

Prescribed Usage

Note the following:



Warning

This device may only be used for the applications described in the catalog or the technical description and only in connection with devices or components from other manufacturers which have been approved or recommended by Siemens. Correct, reliable operation of the product requires proper transport, storage, positioning and assembly as well as careful operation and maintenance.

Trademarks

All names identified by ® are registered trademarks of the Siemens AG. The remaining trademarks in this publication may be trademarks whose use by third parties for their own purposes could violate the rights of the owner.

Copyright Siemens AG 2005. All rights reserved.

The distribution and duplication of this document or the utilization and transmission of its contents are not permitted without express written permission. Offenders will be liable for damages. All rights, including rights created by patent grant or registration of a utility model or design, are reserved.

Disclaimer of Liability

We have reviewed the contents of this publication to ensure consistency with the hardware and software described. Since variance cannot be precluded entirely, we cannot guarantee full consistency. However, the information in this publication is reviewed regularly and any necessary corrections are included in subsequent editions.

Siemens AG
Automation and Drives
Postfach 4848, 90327 Nuremberg, Germany

Siemens AG 2005
Technical data subject to change

Table of contents

| | | |
|----------|---|------------|
| 1 | Introduction | 1-1 |
| 1.1 | Purpose of this documentation | 1-1 |
| 1.2 | Change history | 1-1 |
| 1.3 | Further information..... | 1-1 |
| 2 | General safety instructions | 2-1 |
| 2.1 | General information | 2-1 |
| 2.2 | Correct usage..... | 2-1 |
| 2.3 | Laws and directives | 2-1 |
| 2.4 | Measures | 2-2 |
| 2.5 | Qualified Personnel..... | 2-3 |
| 3 | Description | 3-1 |
| 3.1 | System configuration | 3-1 |
| 3.2 | Applications..... | 3-2 |
| 3.3 | Operation | 3-3 |
| 3.4 | Structure..... | 3-3 |
| 3.5 | Structure of the nameplate..... | 3-5 |
| 3.6 | Mode of operation | 3-5 |
| 3.6.1 | Overview of mode of operation | 3-5 |
| 3.6.2 | Operation of the electronics | 3-6 |
| 3.6.3 | Measuring cell operation | 3-7 |
| 4 | Installation | 4-1 |
| 4.1 | Safety information for installation..... | 4-1 |
| 4.2 | Installing gauge and absolute pressure versions..... | 4-3 |
| 4.2.1 | Information for installing gauge and absolute pressure versions | 4-3 |
| 4.2.2 | Installation for gauge and absolute pressure | 4-4 |
| 4.3 | Installation for level version..... | 4-5 |
| 4.3.1 | Information for installing level version..... | 4-5 |
| 4.3.2 | Installation for level | 4-6 |
| 5 | Connecting | 5-1 |
| 5.1 | Connection safety information | 5-1 |
| 5.2 | Connecting the transmitter | 5-2 |
| 6 | Operation | 6-1 |
| 6.1 | Overview of operation | 6-1 |
| 6.2 | Safety information for operation..... | 6-2 |

| | | |
|----------|---|------------|
| 6.3 | Information on operation | 6-3 |
| 6.4 | Digital display | 6-4 |
| 6.4.1 | Elements of the digital display | 6-4 |
| 6.4.2 | Units display | 6-5 |
| 6.4.3 | Error display | 6-6 |
| 6.4.4 | Mode display | 6-7 |
| 6.4.5 | Status display | 6-7 |
| 6.4.6 | Overflow range | 6-8 |
| 6.5 | Local operation | 6-9 |
| 6.5.1 | Local control elements | 6-9 |
| 6.5.2 | Local operation without digital display | 6-11 |
| 6.5.3 | Operating via keys | 6-12 |
| 6.5.4 | Zero point/limit point | 6-13 |
| 6.5.4.1 | The difference between setting and adjusting | 6-13 |
| 6.5.4.2 | Setting/adjusting zero point | 6-17 |
| 6.5.4.3 | Setting/adjusting limit point | 6-18 |
| 6.5.5 | Setting/adjusting electrical damping | 6-19 |
| 6.5.6 | Blind zero point/limit point | 6-21 |
| 6.5.6.1 | Difference between set/adjust and blind set/adjust | 6-21 |
| 6.5.6.2 | Blind setting the zero point | 6-22 |
| 6.5.6.3 | Blind setting the limit point | 6-23 |
| 6.5.6.4 | Blind adjusting zero point | 6-24 |
| 6.5.6.5 | Blind adjusting limit point | 6-25 |
| 6.5.7 | Zero point calibration | 6-25 |
| 6.5.8 | Current sensor | 6-26 |
| 6.5.9 | Output current in case of fault | 6-27 |
| 6.5.10 | Locking keys | 6-29 |
| 6.5.11 | Releasing key or function lock | 6-30 |
| 6.5.12 | Characteristic curve | 6-30 |
| 6.5.13 | Inset point of the root extraction characteristic curve | 6-31 |
| 6.5.14 | Measured value display | 6-32 |
| 6.5.15 | Unit | 6-33 |
| 7 | Operating functions via HART | 7-1 |
| 7.1 | Operating functions via HART communication | 7-1 |
| 7.2 | Process tag data | 7-2 |
| 7.3 | Measurement | 7-2 |
| 7.4 | Selecting the measurement type | 7-2 |
| 7.4.1 | Measurement type selector | 7-2 |
| 7.4.2 | Overview of measurement types | 7-3 |
| 7.4.3 | Variable mapper | 7-4 |
| 7.4.4 | Measurement type "Pressure" | 7-4 |
| 7.4.5 | Customized characteristic curve | 7-5 |
| 7.4.6 | Measurement type "Level" | 7-6 |
| 7.4.7 | Measurement type "User" | 7-8 |
| 7.4.8 | Measured value status | 7-10 |
| 7.4.9 | Analog output block | 7-13 |
| 7.4.10 | Scaling of the digital display value | 7-15 |
| 7.5 | Setting zero point and limit point | 7-16 |
| 7.6 | Blind setting of zero point and limit point | 7-17 |
| 7.7 | Zero point calibration (position correction) | 7-17 |
| 7.8 | Electrical damping | 7-18 |

| | | |
|-----------|---|-------------|
| 7.9 | Fast response mode | 7-18 |
| 7.10 | Current sensor | 7-18 |
| 7.11 | Fault current | 7-18 |
| 7.12 | Setting the current limits | 7-19 |
| 7.13 | Key lock and write protection | 7-20 |
| 7.14 | Measured value display | 7-21 |
| 7.15 | Selection of the physical unit | 7-22 |
| 7.16 | Bar graph | 7-22 |
| 7.17 | Sensor trim | 7-22 |
| 7.17.1 | Sensor trim | 7-22 |
| 7.17.2 | Trimming of the sensor trim point | 7-23 |
| 7.18 | Current sensor trim | 7-24 |
| 7.19 | Factory calibration | 7-25 |
| 7.20 | Static configuration data | 7-26 |
| 7.21 | Diagnostic functions | 7-27 |
| 7.21.1 | Overview | 7-27 |
| 7.21.2 | Operating hours counter | 7-28 |
| 7.21.3 | Calibration timer and service timer | 7-28 |
| 7.21.4 | Min/max pointer | 7-29 |
| 7.21.5 | Limit modules | 7-30 |
| 7.21.5.1 | Overview of limit modules | 7-30 |
| 7.21.5.2 | Monitoring of current saturation | 7-30 |
| 7.22 | Simulation | 7-32 |
| 7.22.1 | Overview of simulation | 7-32 |
| 7.22.2 | Simulation with a ramp function | 7-33 |
| 7.22.3 | Simulation as fixed value | 7-33 |
| 7.23 | Limit monitor | 7-34 |
| 8 | Commissioning | 8-1 |
| 8.1 | Safety instructions for commissioning | 8-1 |
| 8.2 | Instructions for commissioning | 8-2 |
| 8.3 | Introduction to commissioning | 8-2 |
| 8.4 | Commissioning with steam or liquid | 8-3 |
| 8.5 | Commissioning for gases | 8-4 |
| 9 | Specifications | 9-1 |
| 9.1 | SITRANS P300 gauge pressure / absolute pressure | 9-1 |
| 9.2 | SITRANS P300 gauge pressure / absolute pressure (flush-mounted) | 9-5 |
| 10 | Dimension drawings | 10-1 |
| 10.1 | SITRANS P300 gauge pressure / absolute pressure | 10-1 |
| 10.2 | SITRANS P300 gauge pressure / absolute pressure (flush-mounted) | 10-2 |
| 10.3 | Flanges as per EN and ASME | 10-3 |
| 10.4 | F&B and pharma flange | 10-4 |
| 10.5 | Bioconnect/Biocontrol | 10-5 |

Table of contents

| | | |
|----------|--|------------|
| 10.6 | PMC Style | 10-7 |
| A | Appendix..... | A-1 |
| A.1 | Overview of HART operating structure | A-1 |
| A.2 | Certifications | A-5 |
| A.3 | Pressure equipment directive..... | A-5 |
| B | List of Abbreviations/Acronyms..... | B-1 |
| B.1 | Pressure transmitter abbreviations | B-1 |
| | Index | |

Tables

| | | |
|------------|---|------|
| Table 6-1 | Operating functions | 6-2 |
| Table 6-2 | Message as ticker | 6-5 |
| Table 6-3 | Meaning of the arrow displays | 6-7 |
| Table 6-4 | Operating functions via keys | 6-10 |
| Table 6-5 | Meaning of the lock modes | 6-29 |
| Table 6-6 | Measurement type / Device variables display..... | 6-32 |
| Table 6-7 | Unit for pressure measured value display..... | 6-33 |
| Table 6-8 | Unit for volumes measured value display | 6-34 |
| Table 6-9 | Unit for mass measured value display | 6-34 |
| Table 6-10 | Unit for level measured value display | 6-34 |
| Table 6-11 | Unit for temperature measured value display | 6-35 |
| Table 7-1 | Events which result in a change of status..... | 7-12 |
| Table 7-2 | Meaning of the HART lock modes | 7-20 |
| Table 7-3 | Parameter of the limit monitor | 7-34 |
| Table 7-4 | Parameters of the event counter..... | 7-35 |
| Table B-1 | Variables | B-1 |
| Table B-2 | Units | B-1 |
| Table B-3 | Other abbreviations | B-1 |

Introduction

1.1 Purpose of this documentation

These instructions contain all the information you need for commissioning and using the transmitter.

It is aimed both at persons mechanically installing the device, connecting it electronically, configuring the parameters and commissioning it as well as service and maintenance engineers.

1.2 Change history

Currently released versions of these instructions:

| Edition | Comment | Firmware identifier, nameplate | System integration | Installation path for PDM |
|---------|---------------|--------------------------------|----------------------------------|---------------------------|
| 03/2005 | First edition | FW: 11.03.06 | PDM V 6.00; Dev. R.1 DD Rev.1 | SITRANS P300 |
| 06/2005 | 02 | FW: 11.03.06 | PDM V 6.00; Dev. R.1 DD Rev.1 | SITRANS P300 |

1.3 Further information

Information

The contents of these instructions shall not become part of or modify any prior or existing agreement, commitment or relationship. All commitments on the part of Siemens AG are contained in the respective sales contract which also contains the complete and solely applicable warranty conditions. Any statements contained herein do not create new warranties or modify the existing warranty.

The content reflects the technical status for printing. We reserve the right to make technical changes in the course of further development.

References

If there are references to further information on an aspect described here, these will always be found at the end of a chapter under "See also".

Offices

If you need more information or have particular problems which are not covered sufficiently by the operating instructions, contact your local Siemens office. You will find your local Siemens office on the Internet under:

www.siemens.de/prozessinstrumentierung

Click on "Contact" and select your closest town.

Product information on the Internet

The operating instructions are a constituent part of the enclosed CD "sitrans p TRANSMITTERS" (order number A5E00090345) and is available on the Internet at:

www.siemens.de/sitransp

Click on "More Info" and "-> Operating instructions and manuals".

On the enclosed CD, you will find an extract of the catalog FI 01 "Field devices for process automation" with the current order data. The entire FI 01 catalog is also available at the above Web address.

General safety instructions

2.1 General information

This device left the factory free from safety problems. In order to maintain this status and to ensure safe operation of the device, please observe the safety information and warnings contained in these instructions.

2.2 Correct usage

The device may only be used for the purposes specified in these instructions.

Insofar as they are not expressly stated in these instructions, all changes to the device are the sole responsibility of the user.

2.3 Laws and directives

The regulations of the test certification valid in your country are to be observed.

Electrical connection in hazardous zones with explosive atmospheres

The national directives and laws for hazardous areas valid in your country must be observed for electrical connection. For example, in Germany these are:

- Operational safety regulations
- Directive for the installation of electrical systems in hazardous areas DIN EN 60079-14 (previously VDE 0165, T1)

2.4 Measures

For the sake of safety, the following precautions must be observed:



Warning

Type of protection "pressure-proof encapsulation"

Devices with "pressure-proof encapsulation" protection may only be opened when off circuit.

"Intrinsically safe" protection type

"Intrinsically-safe" devices lose their certification as soon as they are operated on circuits which do not correspond with the test certification valid in their country.

Protection type "limited energy" nL (zone 2)

Devices with "limited energy" may be connected and disconnected while in operation.

Protection type "non-sparking" nA (zone 2)

Devices with "non-sparking" protection may only be connected and disconnected when off circuit.



Warning

Exposure to aggressive and hazardous media

The device can be operated both at high pressure and with aggressive and hazardous media. Therefore, improper use of this device may lead to serious injury and or considerable damage to property. Above all, it must be noted when the device was in use and is to be exchanged.



Caution

Electrostatic Sensitive Devices (ESD)

This device contains electrostatic sensitive devices. Electrostatic sensitive devices may be destroyed by voltages that are undetectable to a human. Voltages of this kind occur as soon as a component or an assembly is touched by a person who is not grounded against static electricity. The damage to a module as a result of overvoltage cannot usually be detected immediately. It may only become apparent after a long period of operation.

2.5 Qualified Personnel

"Qualified personnel" means those who are familiar with the installation, mounting, commissioning and operation of the product. They must have the following, appropriate qualifications for their activities:

- Training or instruction/authorization in operating and maintaining devices and systems according to the safety regulations for electrical circuits, high pressures and aggressive as well as hazardous media.
- For explosion-proof devices: Training or instruction/authorization in carrying out work on electrical circuits for hazardous systems.
- Training and instruction in maintenance and use of adequate safety equipment according to safety regulations.
- Should be trained in first aid.

Description

3.1 System configuration

Overview

The pressure transmitter can be used in a number of system configurations:

- as a stand-alone version, supplied with the necessary auxiliary power
- as part of a complex system environment, e.g. SIMATIC S7

System communication

Communication is via the HART protocol, using:

- HART communicator with at least 4 MB available memory
- PC with HART modem, on which appropriate software is available, e.g. SIMATIC PDM
- Control system which is able to communicate via the HART protocol, e.g. SIMATIC S7 with ET 200M

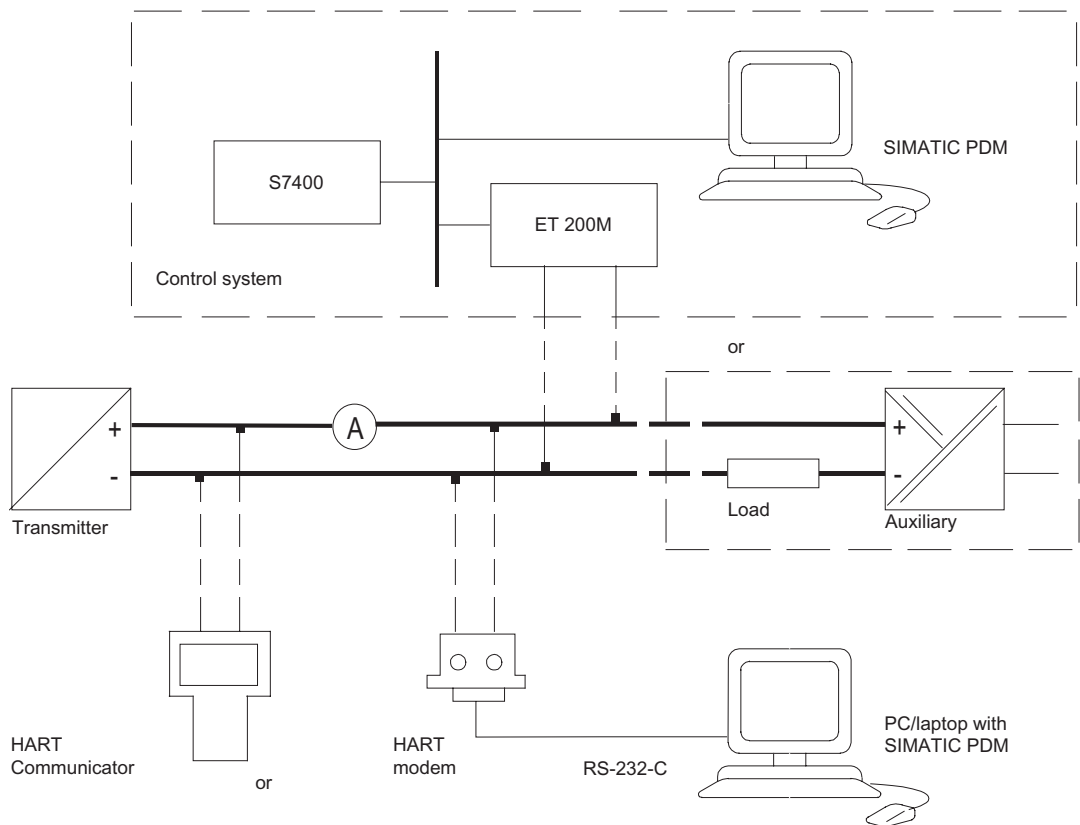

Figure 3-1 Possible system configurations

3.2 Applications

Overview

The pressure transmitter is available in the gauge pressure and absolute pressure versions. The output signal is a load-independent direct current of 4 to 20 mA which is linearly proportional to the input pressure. The pressure transmitter measures aggressive, non-aggressive and hazardous gases, vapors and liquids.

It can be used for the following measurement types:

- Gauge pressure
- Absolute pressure

With appropriate parameter settings, it can also be used for the following additional measurement types:

- Level
- Volume
- Mass

The "intrinsically-safe" EEx version of the transmitter can be installed in hazardous areas (zone 1). The devices have an EC type examination certificate and comply with the appropriate harmonized European CENELEC standards .

Gauge pressure

This version measures aggressive, non-aggressive and hazardous gases, vapors and liquids.

The smallest measuring span is 8 mbar g, the largest 400 bar g.

Level

With appropriate parameter settings, the gauge pressure version measures the level of aggressive, non-aggressive and hazardous liquids.

The level can be measured in an open container.

The parts in contact with the measured medium are made of various materials, depending on corrosion resistance requirements.

Absolute pressure

This version measures the absolute pressure of aggressive, non-aggressive and hazardous gases, vapors and liquids.

The smallest measuring span is 8 mbar a, the largest 30 bar a.

3.3 Operation

Overview

You can operate the basic settings of the pressure transmitter using the buttons on the device. The entire range of settings can be operated via HART communication.

3.4 Structure

Overview

The device comprises:

- Electronics
- Housing
- Measuring cell

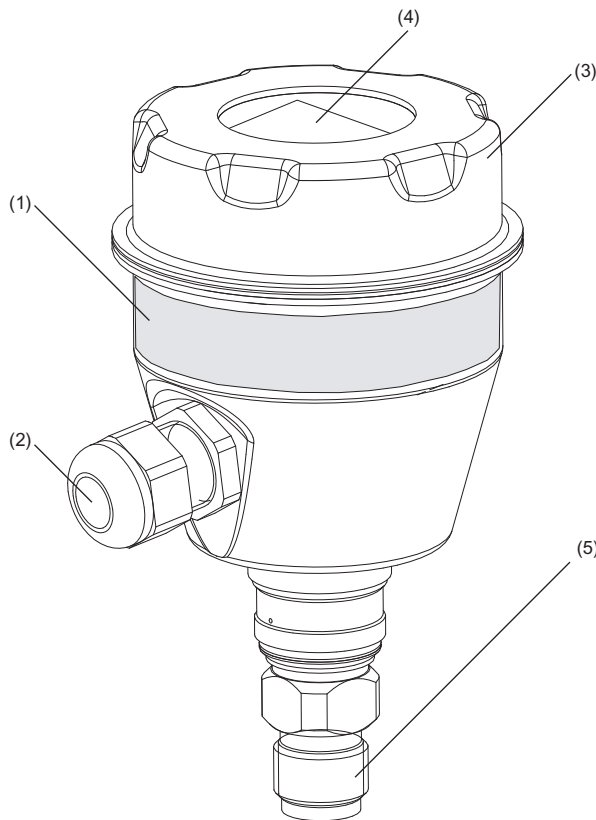

Figure 3-2 Perspective view of the P300

- | | |
|---------------------|------------------------|
| (1) Nameplate | (4) Digital display |
| (2) Cable gland | (5) Process connection |
| (3) Screwable cover | |

The housing has a screwable cover, with or without an inspection window depending on the version. The electrical cable compartment, the buttons for operation of the device and, depending on the version, the digital display are located under this cover. The connections for the auxiliary power U_H and the shield are in the cable compartment. The cable gland is on the side of the housing. The measuring cell with the process connection (5) is located on the underside of the housing. Depending on the version of the device, the measuring cell with the process connection may differ from the one shown in the diagram.

See also

Safety information for installation (Page 4-1)

3.5 Structure of the nameplate

Overview

The nameplate which bears the order number and other important information such as design or technical details is found on the housing.

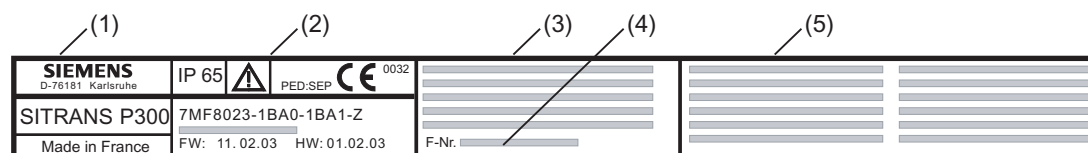

Figure 3-3 Nameplate

- | | | | |
|-----|--------------------------|-----|---------------------------|
| (1) | Product name/manufacture | (4) | Serial number |
| (2) | Product information | (5) | Certification information |
| (3) | Specifications | | |

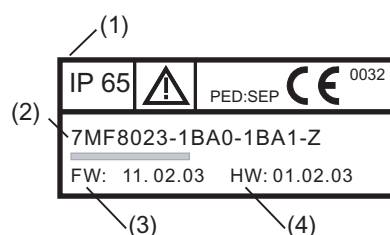

Figure 3-4 Product information

- | | | | |
|-----|----------------------|-----|----------|
| (1) | Degree of protection | (3) | Firmware |
| (2) | Order no. | (4) | Hardware |

3.6 Mode of operation

3.6.1 Overview of mode of operation

This chapter describes how the transmitter works.

First the electronics are described, then the physical principle of the sensors which are used with the various device versions for the individual measurement types.

3.6.2 Operation of the electronics

Description

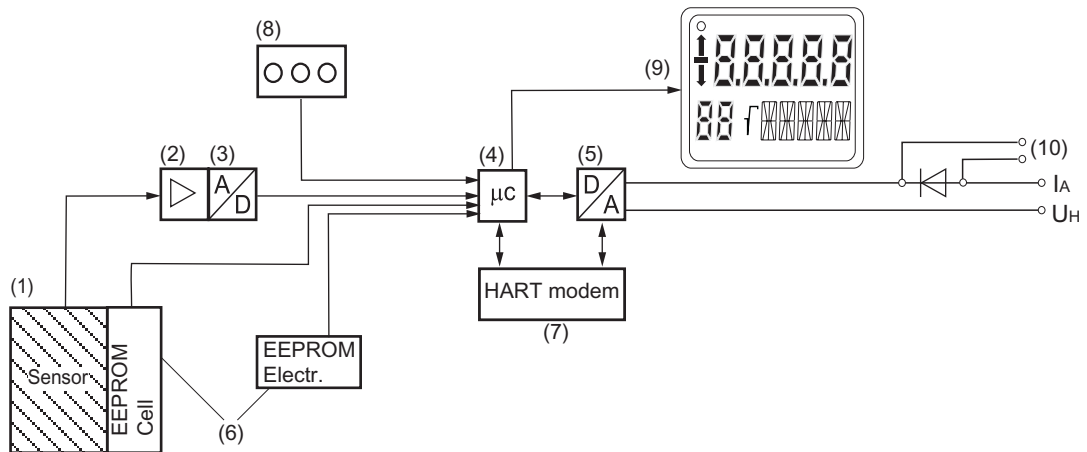

Figure 3-5 Operation of the electronics with HART communication

- (1) Measuring cell sensor
- (2) Measuring amplifier
- (3) Analog-to-digital converter
- (4) Microcontroller
- (5) Digital-to-analog converter
- (6) Each with a non-volatile memory in the measuring cell and in the electronics
- (7) HART modem
- (8) Buttons (local operation)
- (9) Digital display
- (10) Connection for external ammeter
- I_A Output current
- U_H Auxiliary power

The input pressure is converted into an electrical signal by the sensor (1). This signal is amplified by the measuring amplifier (2) and digitized in an analog to digital converter (3). The digital signal is analyzed in a microcontroller (4) and corrected with regard to linearity and thermal characteristics. It is then converted in a digital to analog converter (5) into the output current of 4 to 20 mA. A diode circuit provides reverse voltage protection. You can make an uninterrupted current measurement with a low resistance ammeter at the connection (10). The data specific to the measuring cell, the electronic data and parameter settings are stored in two non-volatile memories (6). The first memory is linked with the measuring cell, the second with the electronics.

The buttons (8) can be used to call up individual functions, called modes. If you have a device with a digital display (9), you can track the mode settings and other messages on it. The basic mode settings can be changed with a computer via the HART modem (7).

3.6.3 Measuring cell operation

In the following sections, the process variable to be measured is called general input pressure.

Overview

The following modes of operation are described:

- Gauge pressure
- Absolute pressure

The following process connections are available, for example:

- G $\frac{1}{2}$
- $\frac{1}{2}$ -14 NPT
- Front-flush membrane:
 - F&B and pharma flange
 - Bioconnect/Biocontrol



Caution

If the measurement signal fails because of sensor breakage, the seal diaphragm may also be destroyed.

In the worst case, the process medium escapes at the process connection in devices for gauge pressure with a span of ≤ 63 bar.

Measuring cell for gauge pressure

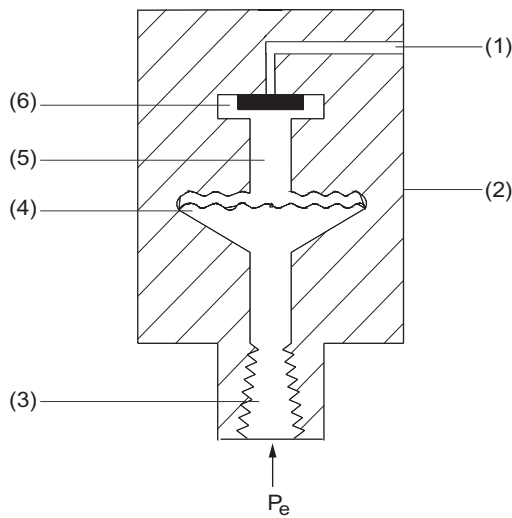

Figure 3-6 Function chart of measuring cell for gauge pressure

- (1) Reference pressure
- (2) Measuring cell
- (3) Process connection
- (4) Separating diaphragm
- (5) Fill liquid
- (6) Gauge pressure sensor
- p_e Input pressure

The input pressure (p_e) is transferred to the gauge pressure sensor (6) via the seal diaphragm (4) and the fill liquid (5), displacing its measuring diaphragm. The displacement changes the resistance value of the four piezo resistors in the measuring diaphragm in a bridge circuit. The change in the resistance causes a bridge output voltage proportional to the input pressure.

The transmitters with spans ≤ 63 bar measure the input pressure against atmosphere, those with spans ≥ 160 bar against vacuum.

Measuring cell for absolute pressure

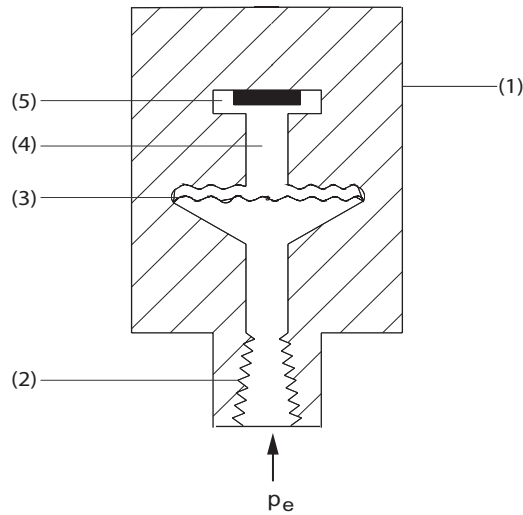

Figure 3-7 Function chart of measuring cell for absolute pressure

- (1) Measuring cell
- (2) Process connection
- (3) Separating diaphragm
- (4) Fill liquid
- (5) Absolute pressure sensor
- p_e Input pressure

The input pressure (p_e) is transferred to the absolute pressure sensor (6) via the seal diaphragm (3) and the fill liquid (4), displacing its measuring diaphragm. The displacement changes the resistance value of the four piezo resistors in the measuring diaphragm in a bridge circuit. The change in the resistance causes a bridge output voltage proportional to the input pressure.

Measuring cell for gauge pressure, front-flush membrane

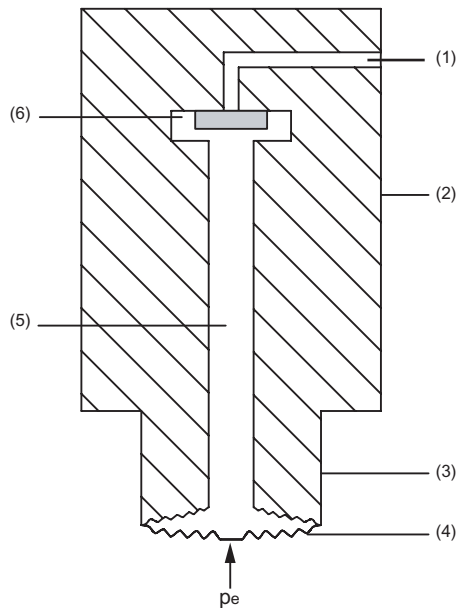

Figure 3-8 Function chart of measuring cell for gauge pressure (front-flush)

- (1) Reference pressure
- (2) Measuring cell
- (3) Process connection
- (4) Separating diaphragm
- (5) Fill liquid
- (6) Gauge pressure sensor
- p_e Input pressure

The input pressure (p_e) is transferred to the gauge pressure sensor (6) via the seal diaphragm (4) and the fill liquid (5), displacing its measuring diaphragm. The displacement changes the resistance value of the four piezo resistors in the measuring diaphragm in a bridge circuit. The change in the resistance causes a bridge output voltage proportional to the input pressure.

Transmitters with spans ≤ 63 bar measure the input pressure against atmosphere, those with spans ≥ 160 bar against vacuum.

Measuring cell for absolute pressure, front-flush membrane

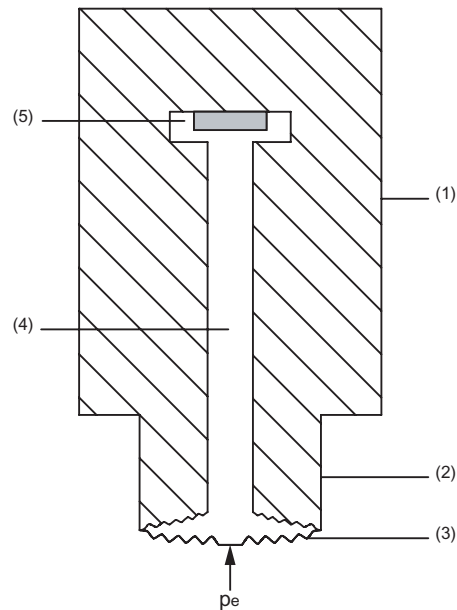

Figure 3-9 Function chart of measuring cell for absolute pressure (front-flush)

- (1) Measuring cell
- (2) Process connection
- (3) Separating diaphragm
- (4) Fill liquid
- (5) Absolute pressure sensor
- p_e Input pressure

The input pressure (p_e) is transferred to the absolute pressure sensor (6) via the seal diaphragm (3) and the fill liquid (4), displacing its measuring diaphragm. The displacement changes the resistance value of the four piezo resistors in the measuring diaphragm in a bridge circuit. The change in the resistance causes a bridge output voltage proportional to the input pressure.

Description

3.6 Mode of operation

Installation

4.1 Safety information for installation

Requirement

The SITRANS P300 transmitter can be installed in different application areas.

Depending on the area of application and the system configuration, there may be differences in the installation.



Warning

Protection against incorrect use of the measuring device

Take particular care to ensure that the selected materials for the wetted parts are suitable for the process media used.

Ignoring this safety measure may cause bodily and life-threatening injury and damage the environment.



Caution

Contact protection is required for surface temperatures $> 70\text{ °C}$.

The shock protection must be designed in such a way that, if there is a buildup of heat, the maximum permitted ambient temperature at the device is not exceeded.

The permissible ambient temperature can be found in the specifications.

Caution

The device may only be used within the measuring range, overload pressure limits and voltage limits dependent on the protection type specified on the nameplate.

Notice

External loads may not be allowed to affect the transmitter as this may result in an incorrect measured value or even destruction of the device. In the worst case scenario, the process medium will escape.



Warning

"Intrinsically-safe" protection type

Information for operating the intrinsically-safe version in hazardous areas:

Operation is only permissible in certified intrinsically-safe circuits. The transmitter corresponds to category 1/2 and may be installed in Zone 0.

The EC type examination certificate applies to installation of the device in the walls of containers and pipes in which explosive gas/air or vapor/air mixtures occur only under atmospheric conditions (Pressure: 0.8 bar to 1.1 bar; Temperature: -20 °C to +60 °C). The permitted range of the ambient temperature is to be found in the specifications or, for explosion-proof devices, in the EC type examination certificate.

The operator may use the device under non-atmospheric conditions outside the limits specified in the EC type examination certificate (or the certification applicable in the country of use) at the operator's own risk if safety measures which may be necessary in accordance with use conditions (explosive mixture) have been taken. The limit values specified in the general specifications are to be complied with in all cases.

Additional information for zone 0

Additional requirements apply for installation in zone 0:

The installation must be sufficiently tight (IP67 according to EN 60 529). For instance, an industry standard (e.g. DIN, NPT) threaded connector is suitable.

When operating with intrinsically safe power supplies in category "EEX ia", explosion safety does not depend on the chemical stability of the isolation membrane.

When operating in Zone 0 with intrinsically safe power supplies in category "EEx ib", a regular leakage test must be performed to test the seal of the isolation membrane of the transmitter. Under these operating conditions, the transmitter may only be used for such combustible gases and liquids for which the seal diaphragm is sufficiently resistant to chemicals and corrosion.

4.2 Installing gauge and absolute pressure versions

4.2.1 Information for installing gauge and absolute pressure versions

Requirements

The installation location is to be as follows:

- Easily accessible
- As close as possible to the measuring point
- Vibration-free
- Within the permitted ambient temperature values

Note

Protect the transmitter against:

- Direct heat radiation
 - Rapid temperature fluctuations
 - Heavy contamination
 - Mechanical damage
-

Notice

Compare the desired operating data with the data on the nameplate.

Notice

The housing may only be opened for maintenance, local operation or to make electrical connections.

Installation configuration

The transmitter may in principle be configured above or below the pressure tapping point. The recommended configuration depends on the medium.

Installation configuration for gases

Install the transmitter above the pressure tapping point.

4.2 Installing gauge and absolute pressure versions

Lay the pressure tubing with a constant gradient to the pressure tapping point, so that any condensate produced can drain in the main line and thereby avoid corruption of the measured values.

Installation configuration for vapor and liquid

Install the transmitter below the pressure tapping point.

Lay the pressure tubing with a constant gradient to the pressure tapping point so that any gas pockets can escape in the main line.

See also

Introduction to commissioning (Page 8-2)

4.2.2 Installation for gauge and absolute pressure

Notice

When installing the process connection of the pressure transmitter, do not turn it on the housing.

Procedure

To install the transmitter for pressure or absolute pressure, proceed as follows:
Attach the transmitter to the process connection with an appropriate tool.

See also

Introduction to commissioning (Page 8-2)

4.3 Installation for level version

4.3.1 Information for installing level version

Requirement

The installation location is to be as follows:

- Easily accessible
- As close as possible to the measuring point
- Vibration-free
- Within the permitted ambient temperature values

Note

Protect the transmitter against:

- Direct heat radiation
 - Rapid temperature fluctuations
 - Heavy contamination
 - Mechanical damage
-

Notice

Compare the desired operating data with the data on the nameplate.

Notice

The housing may only be opened for maintenance, local operation or to make electrical connections.

Installation configuration

The transmitter can only be used in non-pressurized vessels for level.

Installation height

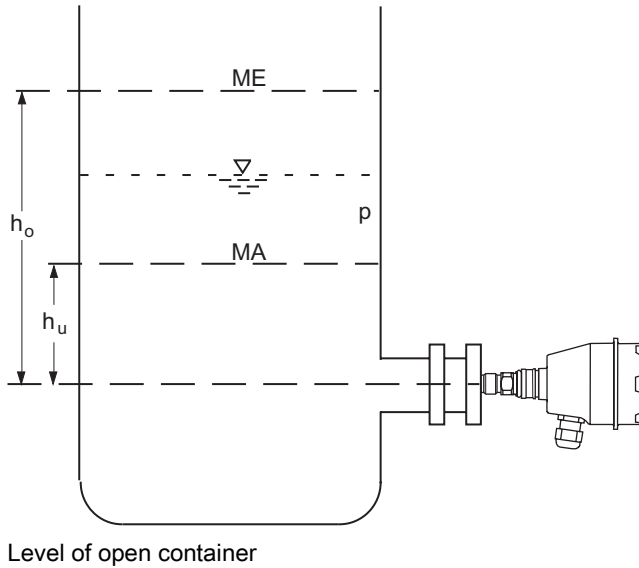

Formula:
 Zero point: $p_{MA} = \rho \cdot g \cdot H_u$
 Zero point: $p_{ME} = \rho \cdot g \cdot H_o$

| | | | |
|-------|-------------|-----------------|---|
| MA | Zero point | Δp_{MA} | Limit point to be adjusted |
| ME | Limit point | Δp_{ME} | Limit point to be adjusted |
| p | Pressure | ρ | Density of the measured medium in the container |
| h_u | Zero point | g | Local gravitational acceleration |
| h_o | Limit point | | |

Note

Select the height of the container flange for recording of the transmitter (*measuring point*) such that the lowest level to be measured is always over the flange or at its upper edge.

4.3.2 Installation for level

Note

Seals are required for the installation.
 Seals are not included in the delivery.

Procedure

To install the transmitter for level, proceed as follows:

1. Attach the seal to the container's mating flange.

Ensure that the seal is centrally positioned and that it does not restrict the movement of the flange's seal diaphragm in any way as otherwise the tightness of the process connection is not guaranteed.

2. Screw on the transmitter's flange.
3. Observe the installation position.

Connecting

5.1 Connection safety information



Warning
Fixed installation

Devices to be operated in hazardous areas should be connected with fixed cable installation. This is not necessary with intrinsically safe devices or devices with "nL" – "limited energy" protection.



Warning
Tightness

Use cable with a cable diameter of 7 to 12 mm for the IP65 or IP68 protection rating.



Warning

Observe the provisions of the test certification valid for your country.

When making electrical connections, observe the national statutes and provisions for hazardous areas valid for your countries.

In Germany these are, for example:

- Operational safety regulations
- Directive for the installation of electrical systems in hazardous areas DIN EN 60079-14 (previously VDE 0165, T1)

If auxiliary power is required, check that it corresponds with that on the nameplate and with the test certification valid for your country.

Note

To improve the reliability:

- Install the signal cable separately from cables with voltages > 60 V.
- Use cable with twisted strands.
- Stay away from large electrical systems.
- Use shielded cable to guarantee the full specification according to HART.
- Connect a load of at least 230 ohms into the signal circuit in order to guarantee fault-free HART communication. When using supply isolation for SMART transmitters, for example: Siemens 7NG4021 a load is already installed in the device.

5.2 Connecting the transmitter

Requirement

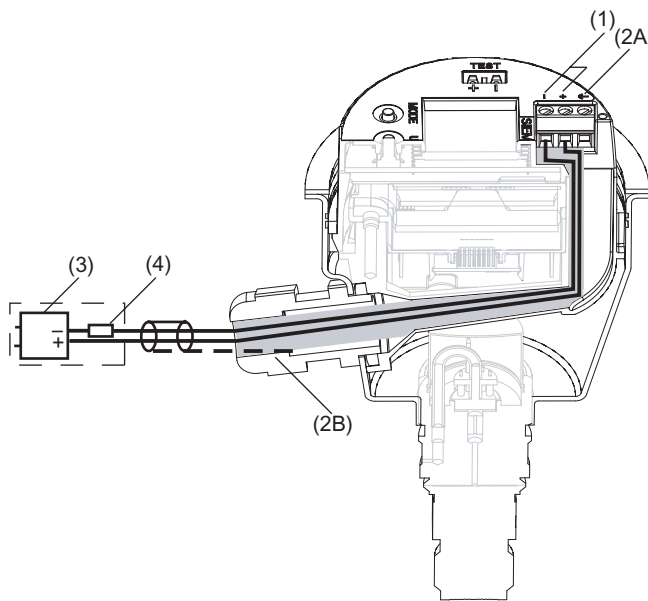

Figure 5-1 Connecting

- | | | | |
|------|---|-----|-----------------------|
| (1) | Supply terminals | (3) | Auxiliary power U_H |
| (2A) | Shield support with plastic cable gland | (4) | Load |
| (2B) | Shield on cable gland | | |

Note

The following values can be set for the load:

- 230 to 1100 Ω for the HART communicator
- 230 to 500 Ω for the HART modem

Procedure

To connect the transmitter, proceed as follows:

1. Strip approx. 14 cm of the cable.
2. Unscrew the cover of the electrical cable compartment.
3. Insert the cable set via the cable gland through a guide channel.
The guide channel connects the cable gland with the cable compartment.
4. Connect the strands to the supply terminals (1) "+" and "-".
Observe the polarity when doing this.
5. If you have a stainless steel cable gland, place the shield on the cable gland (2B).
If you have a plastic steel cable gland, place the shield on the shield support (2A). The shield support is electrically connected with the housing.
6. Screw the cover back into place.

Operation

6.1 Overview of operation

Introduction

The following description provides an overview of the operating functions which can be executed with the pressure transmitter and the safety information which is to be observed when doing so. As the transmitter can be operated on site and via HART communication, first the local operation and then the operating functions via HART will be described.

If there are references to further information on an aspect described here, these will always be found at the end of a chapter under "See also"

Overview

Contents:

- Safety information for operation
- Information on operation
- Digital display
- Local operation

Overview of operating functions

You can operate the basic settings of the pressure transmitter using the buttons on the device. The entire range of settings can be operated via HART communication.

The following table describes the basic operating functions offered by a device with a digital display. The basic variables of the device are highlighted in bold.

Table 6-1 Operating functions

| Function | With buttons | With HART |
|--|--------------|---|
| Zero point | yes | yes |
| Limit point | yes | yes |
| Electrical damping | yes | yes |
| Blind setting of zero point | yes | yes |
| Blind adjusting of limit point | yes | yes |
| Zero point trim (position correction) | yes | yes |
| Current sensor | yes | yes |
| Fault current | yes | yes |
| Keyboard lock and write protection | yes | yes, except for overriding write protection |
| Unit | yes | yes |
| User-specific characteristic | no | yes |
| Diagnostics function | no | yes |
| Measurement type | no | yes |

Further operating functions are accessible via HART for special applications.

If the device does not have a digital display, you can only operate a limited selection on the device. However, the selection of functions available via HART is not affected by this.

See also

Operating functions via HART communication (Page 7-1)

Local control elements (Page 6-9)

6.2 Safety information for operation

Notice

If you have set the basic functions of the pressure transmitter as user defined, the display and measurement output terminal can be adjusted such that the true process pressure is not reproduced.

The basic variables should therefore be checked prior to commissioning.

6.3 Information on operation

Introduction

The following rules apply to the operation of the pressure transmitter:

- The device always counts successively upward from the lowest displayed point.

If you hold the button down for a longer period, it counts to the next highest displayed point. This process allows for a rough adjustment over a wide range. For fine adjustment, use the <UP> or <DOWN> button again. Press the button again.

Violations of the measured value limits are displayed on the digital display with ↑ or ↓.

- To operate the device via the keyboard, the button lock must be released.
- If you operate the transmitter locally, write access via HART is not possible during this time.

However, it is possible to read data, e.g. measured values, at any time.

Note

If more than 2 minutes has passed since the last button was pressed, the setting is automatically saved and the device automatically returns to the measured value display.

6.4 Digital display

6.4.1 Elements of the digital display

Structure

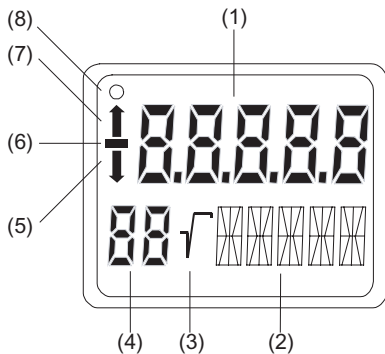

Figure 6-1 Structure of the digital display

- | | |
|----------------------|-------------------------------|
| (1) Measured value | (5) Violation of lower limit |
| (2) Unit/bar graph | (6) Symbol for measured value |
| (3) Root display | (7) Violation of higher limit |
| (4) Mode/button lock | (8) Communication display |

Description

The digital display is used for the local display of the measured value (1) with:

- Unit (2)
- Mode (4)
- Symbol (6)
- Status (5) and (7)

The measured value (1) display displays the following, depending on the customer setting:

- The current emitted by the transmitter
- The percentage measurement value of the adjusted measurement type, e.g. level, relative to the adjusted measurement range.
- The measurement value in a physical unit which can be selected

The displays Violation of lower limit (5) and Violation of upper limit (7) are also referred to as statuses as they have meanings dependent on the settings.

If the communication display (8) flashes, this indicates active communication with, for example, a HART communicator.

6.4.2 Units display

Description

The unit display comprises five 14-segment fields for displaying the unit as a percentage value, physical unit or current value. Alternately to the unit, a bar graph can be displayed which represents the percentage measurement value in the range from 0 to 100%. In the default setting, the function which represents the bar graph is switched off.

Display

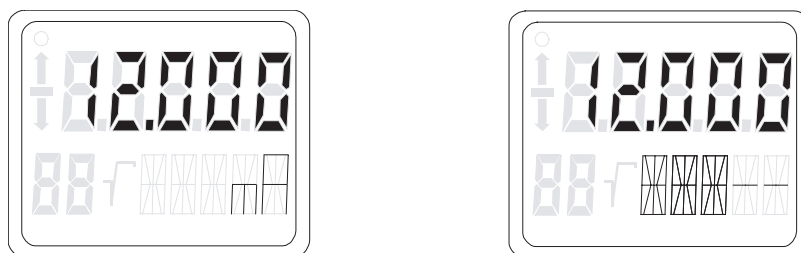

Figure 6-2 Examples for current and bar graph measured value display.

The following messages may appear as a ticker in the bottom line of the digital display. They have no influence on the current output.

Table 6-2 Message as ticker

| Ticker | Meaning |
|----------------------|--|
| "DIAGNOSTIC WARNING" | Is always displayed if: <ul style="list-style-type: none"> • An event configured by the user is to be signaled with a warning. e.g.: <ul style="list-style-type: none"> – Limit reached – Event counter for limit values exceeded – Calibration time expired – Current saturation reached <ul style="list-style-type: none"> • The status of one of the device variables changes to "UNCERTAIN". |
| "SIMULATION" | Is always displayed when the simulation of a pressure value or temperature value is active. |

See also

Measured value status (Page 7-10)

6.4.3 Error display

Description

If hardware faults, software errors or diagnostic alarms occur in the transmitter, the message "Error" appears in the measured value display.

A ticker appears in the lower line of the digital display indicating the type of error. This diagnostic information is also available via HART communication.

Display

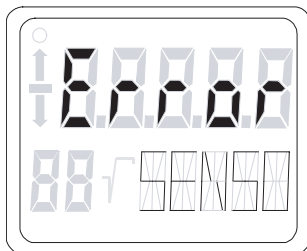

Figure 6-3 Example of error message

The following messages may appear as a ticker in the bottom line of the digital display.

| Ticker | Meaning |
|---------------------------|---|
| "HARDWARE FIRMWARE ALARM" | Contains hardware faults such as: <ul style="list-style-type: none"> • incorrect checksum • incorrect EEPROM data • defective EEPROM • RAM fault • ROM fault • inconsistent data • EEPROMs not initialized |
| "DIAGNOSTIC ALARM" | Is always displayed if <ul style="list-style-type: none"> • an event configured by the user is to be signaled with an alarm. For example: <ul style="list-style-type: none"> – Limit reached – Event counter for limit values exceeded – Calibration time expired – Current saturation reached <ul style="list-style-type: none"> • the status of one of the device variables is "BAD". |
| "SENSOR BREAK" | Appears when there is a sensor break. |

See also

Measured value status (Page 7-10)

6.4.4 Mode display

Description

The selected active mode is shown in the mode display.

Display

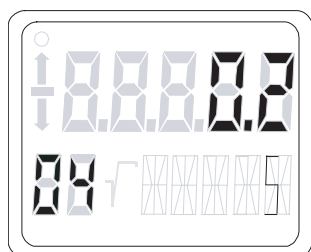

Figure 6-4 Example for mode display

In the example, a damping of 0.2 seconds was set in mode 4.

6.4.5 Status display

Description

The arrows of the status display have a different meaning depending on the mode setting. The table below shows the meanings of the arrows in the respective functions.

Meaning

Table 6-3 Meaning of the arrow displays

| Function | Mode | Display↑ | Display↓ |
|----------------------------|------|---|---|
| Adjusting zero point | 2 | exceeds of the upper current limit | exceeds of the lower current limit |
| Adjusting limit point | 3 | exceeds of the upper current limit | exceeds of the lower current limit |
| Adjusting damping | 4 | exceeds of the upper damping value only for device type pressure | exceeds of the lower damping value only for device type pressure |
| Blind adjusting zero point | 5 | exceeds of the upper sensor limit | exceeds of the lower sensor limit |

| Function | Mode | Display↑ | Display↓ |
|-----------------------------|------------|--|--|
| Blind adjusting limit point | 6 | exceeds of the upper sensor limit | exceeds of the lower sensor limit |
| Position correction | 7 | exceeds of the max. span by more than 5% of the upper current limit | exceeds of the lower current limit |
| Keyboard operation | 2, 3, 5, 6 | when the span to be adjusted is larger than the maximum span | when the span to be adjusted is smaller than the minimum span |
| Normal operation | | Current exceeds the upper saturation limit Pressure exceeds the upper sensor limit. | Current falls below the lower saturation limit Pressure falls below the lower sensor limit. |

6.4.6 Overflow range

Description

The output signal is divided into defined ranges:

- Measuring range
- Saturation limits
- Fault current

The transmitter emits the output current according to the device variables selected as primary variable (PV). The operating range of the current lies between 4 mA and 20 mA.

Meaning

When the measurement limits are exceeded or not reached, the measured values are correctly displayed in the overflow range.

A ticker is displayed in the lower line of the digital display showing the message UNDER or OVER with respect to the selected unit. The possible overflow range can be adjusted via HART communication. If either of the overflow limits are violated, the output current remain constant. Violations of the measured value limits are displayed on the digital display with ↑ or ↓.

Note

The setting of the overflow range and the fault current range can be freely selected via HART communication.

Reference

NAMUR recommendation NE43 of 18.01.94

"Standardization of the signal level for the failure information from digital transmitters with an analog output signal".

See also

Fault current (Page 7-18)

Setting the current limits (Page 7-19)

6.5 Local operation

6.5.1 Local control elements

Introduction

The transmitter can be operated on site with the keys (buttons). Selectable modes can be used to choose and execute the functions described in the table. The number of functions is limited if the device does not have a digital display.

Control elements

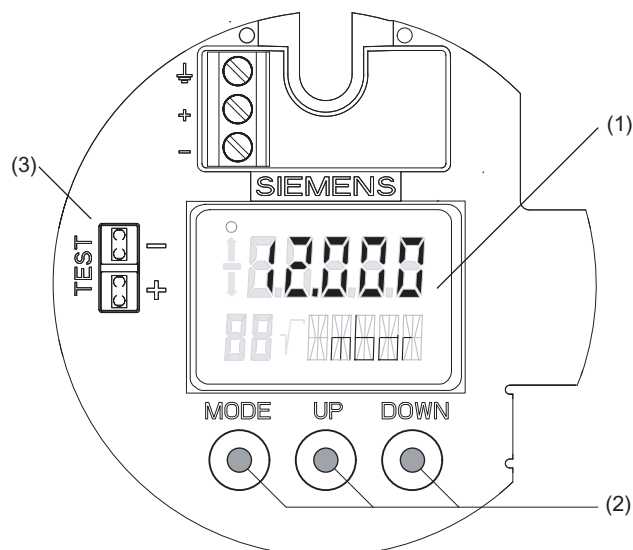

Figure 6-5 Position of keys and digital display

- (1) Digital display
- (3) Test connector

- (2) Keys

Operating functions

Notice

Zero point calibration

For absolute pressure transmitters, the zero point is at vacuum.

A zero point calibration with transmitters which do not measure absolute pressure leads to faulty settings.

Table 6-4 Operating functions via keys

| Function | Mode | Key function | | | Display, explanations |
|---|------------------------------|--|------------------------|--|--|
| | <MODE> | <UP> | <DOWN> | <UP> and <DOWN> | |
| Measured value | The modes are selected here. | | | | The current measured value is displayed as you have adjusted it in the "Measured value display, mode 13" function. |
| Zero point (only with "Pressure" measurement type) | 2 | Current higher | Current lower | Set to 4 mA | Output current in mA |
| Limit point (only with "Pressure" measurement type) | 3 | Current higher | Current lower | Set to 20 mA | Output current in mA |
| Electrical damping | 4 | Damping higher | Damping lower | Set to 0 | Time constant T63 in seconds Adjustment range: 0.0 s to 100.0 s |
| Zero point in so-called blind adjustment | 5 | Pressure higher | Pressure lower | Setting zero point to 0 | Zero point in the selected pressure unit |
| Limit point in so-called blind adjustment | 6 | Pressure higher | Pressure lower | Setting limit point to upper measuring limit | Limit point in the selected pressure unit |
| Zero point calibration (position correction) | 7 | Correction value higher | Correction value lower | Performing | Pressurizing transmitter for gauge pressure or level Evacuating transmitter for absolute pressure (< 0.1% of the span). (Zero point remains unaffected) Measured value in pressure unit |
| Current sensor | 8 | Current higher | Current lower | Switching on | constant output current in mA "3.6"; "4", "12", "20" or "22.8" Switch off with the <MODE> key. |
| Output current in case of fault | 9 | Switching between lower fault current and upper fault current. | | lower fault current | selected output current possible: Fault current limits adjusted by user |

| Function | Mode | Key function | | | Display, explanations | |
|--|--------|--|--|-----------------|---|--|
| | <MODE> | <UP> | <DOWN> | <UP> and <DOWN> | | |
| Key lock or function lock | 10 | Switching between the five functions | – | 0 | None | |
| | | | | LA | all locked | |
| | | | | LO | all locked except for zero point | |
| | | | | LS | all locked except for zero point and limit point | |
| | | | | L | Write protection Operation via HART not possible. | |
| Characteristic curve (not relevant for gauge and absolute pressure) | 11 | Select "lin" in case another adjustment was made. | linear | lin | linear | |
| Inset point of the root extracting characteristic curve (not relevant for gauge and absolute pressure) | 12 | | – | | If you have reached this mode, you have presumably not selected "lin" in mode 11. Select "lin". | |
| Measured value display | 13 | Select from three options. | – | | <ul style="list-style-type: none"> • Display type (input value) • Output current in mA • Measured value in % | |
| Unit | 14 | Select from the table for measured values display. | In each case the first value from the table of the physical unit | | Physical unit | |

See also

Operating functions via HART communication (Page 7-1)
Overview of operation (Page 6-1)

6.5.2 Local operation without digital display

Introduction

Devices with a cover without an inspection window are supplied without digital display and with key lock. If the device does not have a digital display or key lock, limited operation via the keys is still possible depending on the lock mode.

Setting/adjusting zero point/limit point without digital display

You can set or adjust the zero and limit points without a digital display. Further modes can no longer be selected.

The same requirements and mathematical correlations apply as for operation with a digital display.

6.5.3 Operating via keys

Introduction

This overview provides you with most important safety information required to operate the pressure transmitter. The overview also instructs you how to adjust the operating functions on site.

Requirement



Warning

Intrinsically-safe circuits

With intrinsically-safe circuits, use only certified ammeters appropriate for the transmitter.

Specific test certificates

If the transmitter is used as category 1/2 equipment, observe the EC type examination certificate or the certification valid for you country.

Note

The housing should be cleaned to prevent dirt and moisture entering the device.

To operate the device via the keys, the key lock must be released.

Procedure

The device is set to measured value display by default.

To adjust the operating functions, proceed as follows:

1. Unscrew the cover.
2. Press the <MODE> key until the desired mode is displayed.
3. Press the <UP> or <DOWN> key until the desired value is displayed.
4. Press the <MODE> key.

This saves the values and the device then jumps to the next mode.

5. Screw the cover back into place.

Note

If more than 2 minutes has passed since the last key was pressed, the setting is automatically saved and the device automatically returns to the measured value display.

See also

Releasing key or function lock (Page 6-30)

6.5.4 Zero point/limit point

6.5.4.1 The difference between setting and adjusting

Introduction

With the "Pressure" measurement type, you set or adjust the zero point and limit point with the keys. Modes 2 and 3 are used for this. Rising and falling characteristic curves can be realized with appropriate use of the keys. If the transmitter is not using the "Pressure" measurement type, this mode is skipped in local operation.

Difference

The difference between setting and adjusting lies in the calculation.

Setting with reference pressure

Requirement

Two reference pressures p_{r1} and p_{r2} are available. The reference pressures are initialized by the process or generated by a pressure sensor.

With setting, a desired zero point or limit point is allocated to the standard current values (4 mA or 20 mA) After setting, the span specified on the nameplate may no longer correspond with the adjustment.

Depending on the model and measuring range, a maximum downscaling of 1:100 can be achieved (span ratio = r, turn down).

Note

Setting the zero point does not change the span. Setting the limit point does not change the zero point.

The zero point should therefore be set first, then the limit point.

The correlation between the measured pressure and the output current generated is linear. The following formula can be used to calculate the output current.

$$I = \frac{p - MA}{ME - MA} * 16 \text{ mA} + 4 \text{ mA}$$

Figure 6-6 Current calculation formula for setting

| | | | |
|----|----------------|----------------------|-----------------|
| I | Output current | MA _{actual} | Old zero point |
| p | Pressure | ME _{actual} | Old limit point |
| MA | Zero point | MA _{target} | New zero point |
| ME | Limit point | ME _{target} | New limit point |

Example of setting with reference pressure

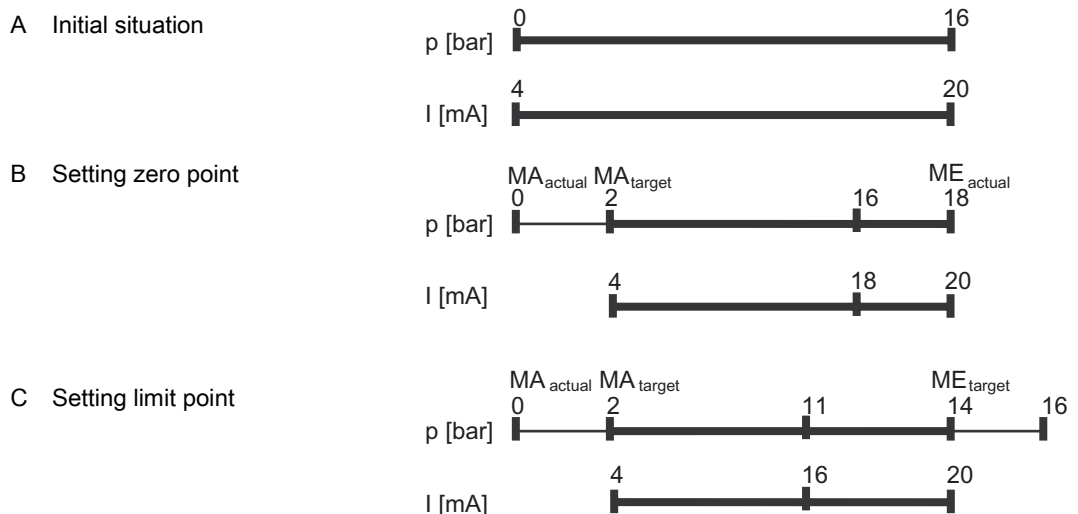

Explanations for the example of setting with reference pressure

- A The measuring range is from 0 to 16 bar. You are changing the zero point from 0 to 2 bar and the limit point from 16 to 14 bar. The span is then 12 bar.
- B 2 bar process pressure is created.
Use the <MODE> key to switch the transmitter to mode 2. To set the zero point, press the keys <UP> and <DOWN> simultaneously for 2 seconds.
If there is 2 bar input pressure, the transmitter produces an output current of 4 mA.
- C 14 bar process pressure is created.
Use the <MODE> key to switch the transmitter to mode 3. To set the limit point, press the keys <UP> and <DOWN> simultaneously for 2 seconds.
If there is 14 bar input pressure, the transmitter produces an output current of 20 mA.
- D The output current can be calculated for any input pressure using the "current calculation formula for setting".

Note

If the preset measuring limits are exceeded or fallen below by more than 20% during setting, the setting function is not carried out and the old value is retained.

With a marked elevation of the zero point, the limit point must therefore previously be reduced such that it still lies within the permitted range after elevation of the zero point. This setting function is only possible with the "Pressure" measurement type.

Adjusting with reference pressure

Requirement:

The reference pressure, the adjusted zero point and adjusted limit point are known.

With adjusting, a zero point or limit point can be allocated to a desired current value with the aid of a reference pressure. This function is particularly suitable when the required pressures for zero point and limit point are not available. After adjustment, the span specified on the nameplate may no longer correspond with the setting.

Using the formulae below, the current to be set for the desired zero point and limit point can be calculated.

To calculate the output currents when setting the zero point or limit point, the reference pressure must be selected so that a value between 4 and 20 mA results for the current.

$$I_{MA} = \frac{p_{ref} - MA_{target}}{ME_{actual} - MA_{actual}} * 16 \text{ mA} + 4 \text{ mA}$$

$$I_{ME} = \frac{p_{ref} - MA_{target}}{ME_{target} - MA_{target}} * 16 \text{ mA} + 4 \text{ mA}$$

Figure 6-7 Current calculation formula for setting with reference pressure

| | | | |
|------------------|--|----------------------|-----------------|
| I | Output current | MA _{actual} | Old zero point |
| I _{MA} | Current to be adjusted with MA _{target} | ME _{actual} | Old limit point |
| I _{ME} | Current to be adjusted with ME _{target} | MA _{target} | New zero point |
| p | Pressure | ME _{target} | New limit point |
| p _{ref} | Existing reference pressure | | |

Example of adjusting with reference pressure

A Initial situation



B Calculating zero point



C Calculating limit point

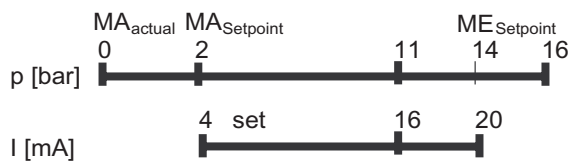

Explanations for the example of adjusting with reference pressure

- A The measuring range is from 0 to 16 bar. You are changing the zero point from 0 to 2 bar and the limit point from 16 to 14 bar. The span is then 12 bar.
A reference pressure of 11 bar is created.
- B Use the <MODE> key to set the transmitter to mode 2.
The "Current calculation formula for adjusting with reference pressure" can be used to calculate the current to be adjusted for the desired zero point I_{MA} (13 mA at 2 bar) with the existing reference pressure. It can be adjusted with the keys <UP> or <DOWN> I_{MA} .
- C Use the <MODE> key to set the transmitter to mode 3.
The "Current calculation formula for adjusting" can be used to calculate the current to be adjusted for the desired limit point I_{ME} (16 mA at 14 bar) with the existing reference pressure. It can be adjusted with the keys <UP> or <DOWN> I_M .

Note

If the preset measuring limits are exceeded or fallen below by more than 20% during adjustment, the resulting current cannot be set above these limits.

With a marked elevation of the zero point, the limit point must therefore previously be reduced such that it still lies within the permitted range after elevation of the zero point.

6.5.4.2 Setting/adjusting zero point

Introduction

The zero point for the pressure transmitter can be set or adjusted in mode 2.
Both the zero point and limit point can be adjusted separately or both values successively.

Requirement

You are familiar with the correct operation of the transmitter and the associated safety information.

You have selected a reference pressure which corresponds to the zero point and lies within the permitted deviation.

The transmitter is using the "Pressure" measurement type.

Setting zero point

To set the output current of the zero point to 4 mA, proceed as follows:

1. Create the reference pressure.
2. Set mode 2.
3. Set the zero point to 4 mA.
4. Save with the <Mode> key.

Adjusting zero point

If you do not set the output current, but continually adjust it, you must mathematically calculate the currents to be adjusted.

To adjust the output current of the zero point, proceed as follows:

1. Create the reference pressure.
2. Set mode 2.
3. Adjust the output current of the zero point to the calculated value.
4. Save with the <Mode> key.

Setting zero point without digital display

You have a device with a cover without an inspection window and want to set the zero point.

To set the output current of the zero point to 4 mA, proceed as follows:

1. Create the reference pressure.
2. Press the keys <UP> and <DOWN> simultaneously.

The device has set the zero point to 4 mA.

3. When you release the keys, the device automatically saves the adjusted value.

Adjusting zero point without digital display

You have a device with a cover without an inspection window and do not want to set the zero point, but rather adjust it.

An ammeter is required to do this.

To adjust the output current of the zero point, proceed as follows:

1. Connect the ammeter to the test connector.
2. Create the reference pressure.
3. Adjust the output current of the zero point with <UP> or <DOWN> key.
4. When you release the key, the device automatically saves the value.

See also

Operating via keys (Page 6-12)

6.5.4.3 Setting/adjusting limit point

Introduction

The zero point for the pressure transmitter can be set or adjusted in mode 3.

Both the zero point and limit point can be adjusted separately or both values successively.

Requirement

You are familiar with the correct operation of the transmitter and the associated safety information.

You have selected a reference pressure which corresponds to the limit point and lies within the permitted deviation.

The transmitter is using the "Pressure" measurement type.

Setting limit point

To set the output current of the limit point to 20 mA, proceed as follows:

1. Create the reference pressure.
2. Set mode 3.
3. Set the limit point to 20 mA.
4. Save with the <Mode> key.

Adjusting limit point

If you do not set the output current, but continually adjust it, you must mathematically calculate the currents to be adjusted.

To adjust the output current of the limit point, proceed as follows:

1. Create the reference pressure.
2. Set mode 3.
3. Adjust the output current of the limit point to the calculated value.
4. Save with the <MODE> key.

Setting limit point without digital display

You have a device with a cover without an inspection window and want to set the limit point.

To set the output current of the limit point to 20 mA, proceed as follows:

1. Create the reference pressure.
2. Press and hold down the <MODE> key.
3. Additionally, press the keys <UP> and <DOWN> simultaneously.

The device has set the limit point to 20 mA.

4. When you release the keys, the device automatically saves the value.

Adjusting limit point without digital display

You have a device with a cover without an inspection window and do not want to set the limit point, but rather adjust it.

An ammeter is required to do this.

To adjust the output current of the limit point, proceed as follows:

1. Connect the ammeter to the test connector.
2. Create the reference pressure.
3. Press and hold down the <MODE> key.
4. Adjust the output current of the limit point to the calculated value with <UP> or <DOWN> key.
5. When you release the key, the device automatically saves the value.

See also

Operating via keys (Page 6-12)

6.5.5 Setting/adjusting electrical damping

The difference between setting and adjusting

The time constant of the electrical damping can be set or adjusted via the keys. Setting means that the time constant is automatically set to 0 seconds. Adjusting means that the time constant is adjusted in 0.1 second steps between 0 and 100 seconds. This electrical damping also acts as the device's own basic damping.

"Setting" requirement

You are familiar with the correct operation of the transmitter and the associated safety information.

Setting electrical damping

To set the electrical damping to 0 seconds, proceed as follows:

1. Set mode 4.
2. Press the keys <UP> and <DOWN> simultaneously.
3. Save with the <MODE> key.

Result

Electrical damping is set to 0 seconds.

"Adjusting" requirement

The basic calibration of the steps is a 0.1 second interval. The longer you depress the <UP> and <DOWN> key, the greater the steps.

Adjusting electrical damping

To adjust the electrical damping, proceed as follows:

1. Set mode 4.
2. Adjust the desired damping.
3. Save with the <MODE> key.

Result

Electrical damping has been adjusted to the desired time constant.

See also

Operating via keys (Page 6-12)

6.5.6 Blind zero point/limit point

6.5.6.1 Difference between set/adjust and blind set/adjust.

Difference

In contrast to setting/adjusting with a reference pressure, you do not need a reference pressure for blind setting/adjusting. Furthermore, you adjust a value in the physical variable "pressure" without a reference pressure, and an output current with a reference pressure.

Adjusting blind

First select the desired physical unit. Then use the <UP> and <DOWN> keys to adjust two pressure values and save them in the device. These theoretical pressure values are allocated to the standard current values 4 mA and 20 mA.

Depending on the model and measuring range, a maximum downscaling of 1:100 can be achieved (span ratio = r, turn down).

The correlation between the measured pressure and the output current generated is linear.

Example of adjusting blind

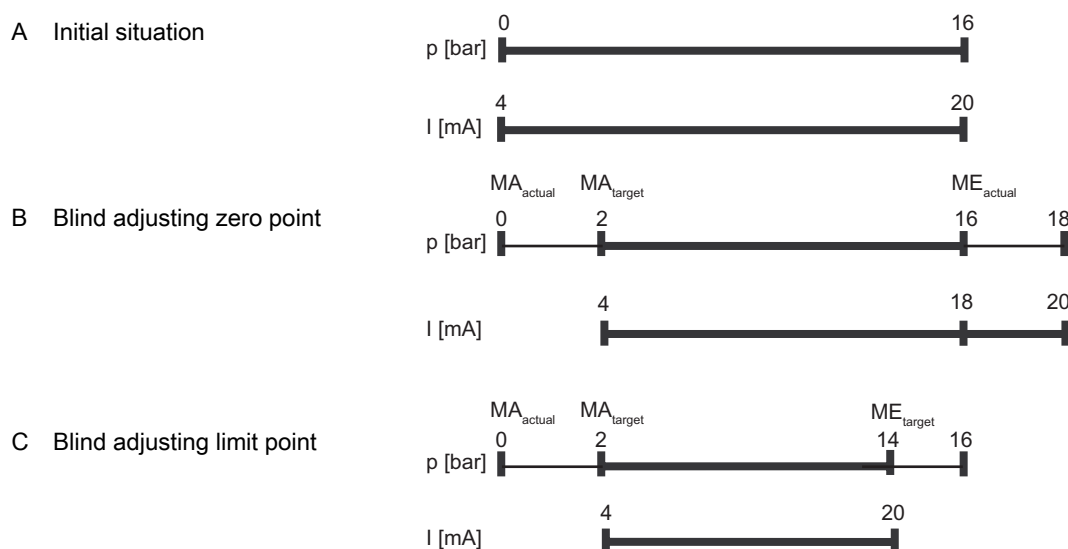

| | | | |
|---------------|-----------------|---------------|-----------------|
| I | Output current | p | Pressure |
| MA_{actual} | Old zero point | MA_{target} | New zero point |
| ME_{actual} | Old limit point | ME_{target} | New limit point |

Explanations for the blind adjusting example

- A The measuring range is from 0 to 16 bar. You are changing the zero point from 0 to 2 bar and the limit point from 16 to 14 bar. The span is then 12 bar.

In this example you create no pressure.

- B Use the <MODE> key to switch the transmitter to mode 5. To adjust the zero point to 2 bar, press one of the keys <UP> or <DOWN>.

If there is 2 bar input pressure, the transmitter produces an output current of 4 mA.

- C Use the <MODE> key to switch the transmitter to mode 6. To adjust the limit to 14 bar, press one of the keys <UP> or <DOWN>.

If there is 14 bar input pressure, the transmitter produces an output current of 20 mA.

Note

If the preset measuring limits are exceeded or fallen below by more than 20% during adjustment, the resulting current cannot be set above these limits.

With a marked elevation of the zero point, the limit point must therefore previously be reduced such that it still lies within the permitted range after elevation of the zero point.

Setting without reference pressure

Blind setting resets the zero point to the lower sensor limit and the limit point to the upper sensor limit.

Note

If the preset measuring limits are exceeded or fallen below by more than 20% during setting, the setting function is not carried out and the old value is retained.

With a marked elevation of the zero point, the limit point must therefore previously be reduced such that it still lies within the permitted range after elevation of the zero point.

See also

Unit (Page 6-33)

6.5.6.2 Blind setting the zero point

Introduction

Blind setting resets the zero point to the lower sensor limit.

Note

Changes to modes 5 and 6 effect the pressure scaling only. The scaling for level or user-specific characteristic curve remains unaffected by it. Therefore only pressure measured values and pressure units are displayed in these modes.

Requirement

You are familiar with the correct operation of the transmitter and the associated safety information.

There is no reference pressure and you have selected a pressure unit.

Procedure

To blind set the zero point, proceed as follows:

1. Set mode 5.
2. Press the keys <UP> and <DOWN> simultaneously for 2 seconds.

See also

Operating via keys (Page 6-12)

6.5.6.3 Blind setting the limit point**Introduction**

Blind setting resets the limit point to the upper sensor limit.

Note

Changes to modes 5 and 6 effect the pressure scaling only. The scaling for level or user-specific characteristic curve remains unaffected by it. Therefore only pressure measured values and pressure units are displayed in these modes.

Requirement

You are familiar with the correct operation of the transmitter and the associated safety information.

There is no reference pressure and you have selected a pressure unit.

Procedure

To blind set the limit point, proceed as follows:

1. Set mode 6.
2. Press the keys <UP> and <DOWN> simultaneously for 2 seconds.

See also

Operating via keys (Page 6-12)

6.5.6.4 Blind adjusting zero point

Introduction

With blind adjustment, you set the pressure value of the zero point continually and without reference pressure.

Note

Changes to modes 5 and 6 effect the pressure scaling only. The scaling for level or user-specific characteristic curve remains unaffected by it. Therefore only pressure measured values and pressure units are displayed in these modes.

It is possible to switch between a rising and falling characteristic curve.

Requirement

You are familiar with the correct operation of the transmitter and the associated safety information.

There is no reference pressure and you have selected a pressure unit.

Procedure

To blind adjust the pressure value of the zero point, proceed as follows:

1. Set mode 5.
2. Adjust the pressure value of the zero point.
3. Save with the <MODE> key.

See also

Operating via keys (Page 6-12)

6.5.6.5 Blind adjusting limit point

Introduction

With blind adjustment, you adjust the pressure value of the limit point continually and without reference pressure.

Note

Changes to modes 5 and 6 effect the pressure scaling only. The scaling for level or user-specific characteristic curve remains unaffected by it. Therefore only pressure measured values and pressure units are displayed in these modes.

It is possible to switch between rising and falling characteristic curves by interchanging the values for zero and limit points.

Requirement

You are familiar with the correct operation of the transmitter and the associated safety information.

There is no reference pressure and you have selected a pressure unit.

Procedure

To blind adjust the pressure value of the limit point, proceed as follows:

1. Set mode 6.
2. Adjust the pressure value of the limit point.
3. Save with the <MODE> key.

See also

Operating via keys (Page 6-12)

6.5.7 Zero point calibration

Introduction

The zero point is calibrated in mode 7. Zero point calibration corrects zero point errors resulting from the installation position of the pressure transmitter. The device type determines the way in which you proceed.

SIMATIC PDM or the HART Communicator will display the total of all zero point corrections.

Requirement

You are familiar with the correct operation of the transmitter and the associated safety information.

Zero point calibration for gauge pressure transmitter

To calibrate the zero point, proceed as follows:

1. Pressurize the transmitter.
2. Set mode 7.
3. Press the keys <UP> and <DOWN> simultaneously.
4. Save with the <MODE> key.

Zero point calibration for absolute pressure transmitter

Note

You need a reference pressure known to you which lies within the measuring limits.

To calibrate the zero point, proceed as follows:

1. Create the reference pressure.
2. Set mode 7.
3. Set the reference pressure on the digital display.
4. Save with the <MODE> key.

See also

Operating via keys (Page 6-12)

6.5.8 Current sensor

Introduction

The pressure transmitter is set to constant current operation in mode 8. An external current sensor can be connected in constant current operation. Then the current no longer corresponds to the process variable. The following output currents can be adjusted irrespective of the input pressure:

- 3.6 mA
- 4.0 mA
- 12.0 mA

- 20.0 mA
- 22.8 mA

It is also possible to set intermediate values via HART communication.

Procedure

To switch on the constant current operation, proceed as follows:

1. Set mode 8.
"Cur" for Current is shown in the digital display.
2. Press the keys <UP> and <DOWN> simultaneously.
3. Select the constant current.

Switching off constant current operation

To switch off the constant current operation, proceed as follows:

Press <MODE> in mode 8.

See also

Operating via keys (Page 6-12)

6.5.9 Output current in case of fault

Introduction

When a fault occurs, the lower fault current is displayed in the basic setting. In mode 9 you can choose between the output of the upper and lower fault current. The standard values 36 mA and 22.8 mA are set.

The standard values of the upper and lower fault current can be changed via HART communication.

Requirement

You are familiar with the correct operation of the transmitter and the associated safety information.

Procedure

To change the fault current, proceed as follows:

1. Set mode 9.
2. Select the fault current.
3. Save with the <MODE> key.

Note

If a current saturation alarm is active, the setting of the output current may deviate from your setting in case of a fault.

Resetting fault current

To reset the fault current to the basic setting, proceed as follows:

Press the keys <UP> and <DOWN> simultaneously.

Fault causes

Fault currents may be triggered by:

- FW alarm
- HW alarm
- Diagnostic interrupt
- Sensor breakage
- Measured value status BAD

Reference

NAMUR recommendation NE43 of Jan 18 1994:

"Standardization of the signal level for the breakdown information of digital transmitters with analog output signal"

See also

Operating via keys (Page 6-12)

6.5.10 Locking keys

Introduction

Functions which can generally be carried out via the keys can be locked in mode 10. Application examples for a lock include the safeguarding of the saved parameters.

Lock options

You have the following lock options on the pressure transmitter:

Table 6-5 Meaning of the lock modes

| Lock mode | Meaning |
|-----------|---|
| 0 | The device can be operated by means of the keys and HART communication. |
| LA | Keys on the transmitter are locked. Exception: <ul style="list-style-type: none"> • Releasing key lock The device can be operated by means of HART communication. |
| LO | Keys on the transmitter are partially locked. Exception: <ul style="list-style-type: none"> • Setting zero point • Releasing key lock The device can be operated by means of HART communication. |
| LS | Keys on the transmitter are partially locked. Exception: <ul style="list-style-type: none"> • Setting zero point • Setting limit point • Releasing key lock The device can be operated by means of HART communication. |
| L | Write protection Operation via the keys and HART communication is locked. Exception: <ul style="list-style-type: none"> • Releasing key lock |

Requirements

You are familiar with the correct operation of the transmitter and the associated safety information.

Note

Check the measured value display function to see whether the desired setting is displayed.

Procedure

To lock the keys, proceed as follows:

1. Set mode 10.
2. Select the desired lock mode.
3. Confirm the lock mode by pressing <MODE>.

See also

Operating via keys (Page 6-12)

6.5.11 Releasing key or function lock

Releasing key lock

To release a set key lock (LA, LO, LS) with the keys, proceed as follows:

Press <MODE> for 5 seconds.

Remove write protection

To release a write protection for HART (L) using the keys, proceed as follows:

Press <MODE> for 5 seconds.

See also

Operating via keys (Page 6-12)

Monitoring of current saturation (Page 7-30)

6.5.12 Characteristic curve

Introduction

The characteristic curve representing the relationship between the output current and input pressure can be adjusted in mode 11.

Set "lin" with gauge and absolute pressure transmitters, as other characteristic curves are reserved for differential pressure.

Requirement

You are familiar with the correct operation of the transmitter and the associated safety information.

Procedure

To adjust the characteristic curve, proceed as follows:

1. Set mode 11.
2. Select the type of characteristic curve.
3. Save with the <Mode> key.

6.5.13 Inset point of the root extraction characteristic curve

Introduction

If you have reached mode 12, you have already set a root extraction characteristic curve in mode 11. A root extraction characteristic curve is only meaningful for a differential pressure transmitter.

Requirement

You are familiar with the correct operation of the transmitter and the associated safety information.

Procedure

To deactivate mode 12, proceed as follows:

- Set mode 11.
- Select the "lin" type of characteristic curve.
- Save with the <Mode> key.

6.5.14 Measured value display

Introduction

The following types of measured value display are set in mode 13:

- mA
- %
- Measurement type "Pressure", if no other setting has been made via HART communication.

Table 6-6 Measurement type / Device variables display

| DV | Meaning | Digital display |
|----|--|------------------|
| 0 | Pressure | P |
| 1 | Sensor temperature | t-SE |
| 2 | Electronics temperature | t-EL |
| 3 | Pressure value (untrimmed) | P-UNC |
| 4 | Level | LEVEL |
| 5 | Volume | Vol |
| 6 | Mass | MASS |
| 7 | Volume of flow (not relevant for gauge and absolute pressure) | V-Flo |
| 8 | Mass flow rate (not relevant for gauge and absolute pressure) | M-Flo |
| 9 | User | CUS _t |

Requirement

You are familiar with the correct operation of the transmitter and the associated safety information.

Procedure

To select the display type, proceed as follows:

1. Set mode 13.
2. Select the measured value display.
3. Save with the <Mode> key.

See also

Operating via keys (Page 6-12)

Measured value display (Page 7-21)

6.5.15 Unit

Introduction

In mode 14, set the physical unit in which the device's measured value display should be represented.

Requirement

You are familiar with the correct operation of the transmitter and the associated safety information.

You have already selected the desired measured value display in mode 13.

Procedure

To adjust the physical unit, proceed as follows:

1. Set mode 14.
2. Select a unit.
3. Save with the <Mode> key.

Units

Table 6-7 Unit for pressure measured value display

| Unit | Display |
|--------------------------------|---------|
| mbar | mbar |
| bar | bar |
| mm water gauge (4°C/39°F) | m4H2O |
| Inch water gauge (4°C/39°F) | i4H2O |
| ATM | ATM |
| Torr | TORR |
| g/cm ² | Gcm2 |
| Kg/cm ² | KGcm2 |
| MPa | MPa |
| KPa ² | KPa |
| Pa | Pa |
| Psi | PSi |
| mm mercury column | mmHG |
| mm water gauge (20°C/68°F) | mmH2O |
| Foot water gauge (20°C/68°F) | FTH2O |
| Inch mercury column | in_HG |
| Inch water gauge (20 °C/68 °F) | InH2O |

Table 6-8 Unit for volumes measured value display

| Unit | Display |
|----------------------------|---------|
| m ³ | M3 |
| Liters | L |
| Hectoliters | HL |
| US gallons | Gal |
| British gallons | imGal |
| British barrels | bbl |
| British barrels, liquid | bblli |
| Bushels | buShl |
| Yard ³ | Yd3 |
| Foot ³ | FT3 |
| Inch ³ | in3 |
| Standard l | STdl |
| Standard m ³ | STdm3 |
| Standard feet ³ | STFT3 |

Table 6-9 Unit for mass measured value display

| Unit | Display |
|------------|---------|
| Gram | G |
| Kilogram | KG |
| Tons | T |
| Short tons | STon |
| Long tons | ITon |
| Pounds | lb |
| Ounces | OZ |

Table 6-10 Unit for level measured value display

| Unit | Display |
|------|---------|
| Foot | FT |
| Inch | inch |
| m | m |
| cm | cm |
| mm | mm |

Table 6-11 Unit for temperature measured value display

| Unit | Display |
|--------------|----------------|
| ° Celsius | ° / C |
| ° Fahrenheit | ° / F |
| Kelvin | K |
| Rankine | R |

See also

Operating via keys (Page 6-12)

Selection of the physical unit (Page 7-22)

Operating functions via HART

7.1 Operating functions via HART communication

Requirement

The following is required to operate the transmitter via HART communication:

- A HART Communicator or PC software such as SIMATIC PDM.
- A HART modem to connect a PC with the transmitter or a lead to connect a HART Communicator with the transmitter.

Introduction

The transmitter can be operated via HART communication. The full functionality of the transmitter is available via HART communication. The HART Communicator and PC software are not supplied with the transmitter. How to connect and operate a HART Communicator or the PC software is described in separate operating instructions or in the online help for both these tools.

As soon as you have set up the HART communication and the transmitter, you can adapt the transmitter to your relevant measuring task by setting a few parameters. When doing so you are assisted by the measurement types "Pressure", "Level" and a user programmable "Characteristic curve". One or more device variables are permanently allocated to each measurement type (measurement block). These device variables are displayed via PC software such as SIMATIC PDM or via a HART Communicator.

The following components are described in more detail in these operating instructions:

- Process tag data
- Measurement
- Selecting the measurement types
- Measurement type selector/mapper
- Variable mapper
- Measurement type "Pressure"
- Measurement type "Level"
- User-specific characteristic
- Measurement type "User"
- Measured value status
- Analog output

See also

Local control elements (Page 6-9)

Overview of operation (Page 6-1)

7.2 Process tag data

You can store the data for your process tags in fields that can be freely edited. The following table shows how these fields are structured and the form in which you need to enter information into these fields:

| Array | Meaning | Input form |
|------------------|-------------------------------------|--------------------|
| TAG | Process tag name | Eight characters |
| long TAG | Long name of process tag | 32 characters |
| Description | | 16 characters |
| Message | | 32 characters |
| Installation no. | | Integer |
| Date | | Month:Day:Year |
| Special | Freely writable material parameters | 21 x 16 characters |

7.3 Measurement

When the communication indicator is flashing on the digital display, the pressure transmitter is exchanging data via HART communication.

7.4 Selecting the measurement type

7.4.1 Measurement type selector

Measurement type selector

The device variables "Pressure", "Sensor temperature", "Electronics temperature", and "Pressure (untrimmed)" are active regardless of the measurement type and are therefore always displayed. The other device variables become active when the associated measurement types have been selected using the measurement type selector. The inactive device variables have the status CONSTANT. If a measurement type has been selected using the measurement type selector, it has to be configured. The parameter setting does not automatically affect the output of current. For that, you need to switch the corresponding device variable to "Primary Variable" (PV) using the "mapper".

The following device variables are available:

- Pressure
- Sensor temperature
- Electronics temperature
- Pressure (untrimmed)

These device variables are always active and are therefore always displayed.

All other device variables only contain a valid measurement value if the associated measurement type has been activated and also configured.

The inactive device variables have the status CONSTANT.

7.4.2 Overview of measurement types

Overview

With a few parameters, the transmitter can be set to the relevant measuring task. When doing so, you are aided by the following selectable measurement types and a user programmable characteristic curve:

- Pressure
- Level

One or more device variables are permanently allocated to each measurement type. These device variables are displayed in SIMATIC PDM or in the HART Communicator and are activated using the buttons in the following order:

- Pressure
- Sensor temperature
- Electronics temperature
- Pressure (untrimmed)

When operating via HART communication, you will find the following as well:

- Measurement type selector

You can use this selector to switch between the measurement types "Pressure", "Level", and a characteristic curve that can be programmed by the user.

The device variables are always active and are therefore always displayed. All other device variables only contain a valid measurement value if the associated block has been activated and also configured. The inactive device variables have the status CONSTANT.

In addition to the "Pressure" block, you can use the measurement type selector to activate one of the other three blocks, "Sensor temperature", "Electronics temperature", or "Pressure (untrimmed)". In that case, it needs to be configured with the applicable parameters. This does not mean that this block automatically influences the output of current (4 to 20 mA). For that, you need to switch the corresponding device variable to "Primary Variable" (PV) using a "mapper".

Measurement type "Pressure" => Device variable "Pressure", "Sensor temperature", "Electronics temperature", "Pressure (untrimmed)"

7.4.3 Variable mapper

Introduction

In SITRANS P300, the dynamic variable that determines the behavior of current output is always called the Primary Variable (PV). You need to use the mapper for a number of purposes, including selecting which device variable is to be switched to PV. The variable selected as PV using a PC program such as SIMATIC PDM or using the HART Communicator is scaled once again in the analog output stage to a zero value and a limit value. These two values then correspond to the current values 4 and 20 mA.

As soon as the PV is switched over using the mapper, these zero and limit values in the analog output stage are preset to the limit values of the new device variables. You can define these limit values within the individual block functions.

The dynamic variables "Primary", "Secondary", "Tertiary" and "Quarternary" (PV, SV, TV, QV) can be interconnected with any active device variables. Various different measurement type examples are conceivable with a 4 bar pressure transmitter.

See also

Measured value status (Page 7-10)

7.4.4 Measurement type "Pressure"

Introduction

The "Pressure" measurement type contains the "Sensortrim" function and is always active as the default measurement type. If the measurement type selector is set to "Off", no further measured variables will be inferred from the measured variable "Pressure". All device variables apart from the first four are marked as inactive and are given the status CONSTANT. These four variables are mapped by default to the dynamic variables PV, SV, TV and QV.

Switching an inactive device variable to the Primary Variable (PV) generates a fault message since the variable does not contain a valid measured value at that point in time. This message is shown in SIMATIC PDM or in the HART Communicator.

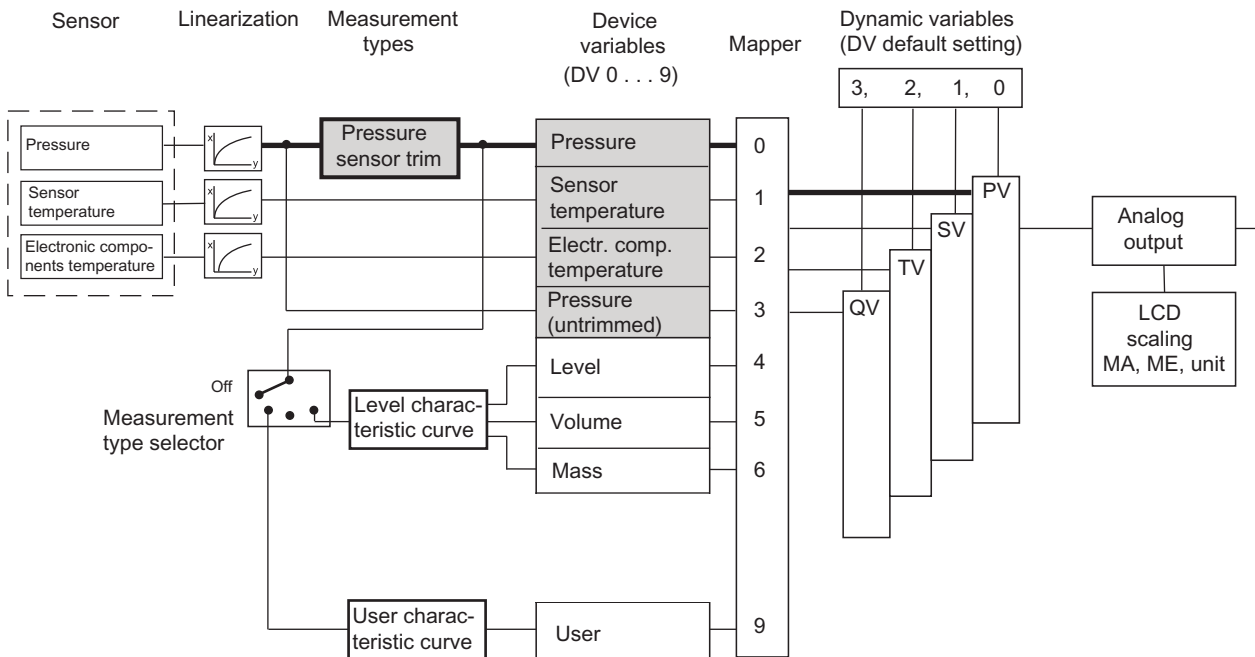

Figure 7-1 Measurement type "Pressure"

| | | | |
|----|----------------------|----|-------------|
| DV | Device Variable | MA | Zero value |
| PV | Primary Variable | ME | Limit value |
| SV | Secondary Variable | | |
| TV | Tertiary Variable | | |
| QV | Quarternary Variable | | |

7.4.5 Customized characteristic curve

Introduction

The customized "characteristic curve" is continuously active as an identical function in the two following measurement types "Level" and "User". This means that it always provides a result for the following function, thus also influencing the measured value status of the affected device variables.

In the device, the characteristic curve vertices are only provided once in the non-volatile memory. Therefore, if the measurement type is changed, you will usually need to adjust the characteristic curve accordingly.

The characteristic curve function requires the input of at least two and up to 30 characteristic curve vertices, entered as pairs of values x%;y%. The values for the x-coordinate are only

accepted by the device when they run monotonically. The y-coordinates, on the other hand, may also be non-monotonic. However, a warning will be issued by the configuring device, which you as the user have to recognize and acknowledge. The output of the characteristic curve is not explicitly stored in a device variable, but rather is directly interconnected with the input of the next function block in each case. The pairs of values 0%;0% and 100%;100% are set as default values. In principle, rising and falling characteristics can be configured. However, with regard to the device variable status, rising characteristics are preferable since otherwise HIGH LIMIT and LOW LIMIT will have the opposite meaning.

See also

Measured value status (Page 7-10)

7.4.6 Measurement type "Level"

Introduction

Once you have configured the measurement type "Level", the device variables "Level", "Volume" and "Mass" are activated. They are all inferred from the measured pressure. The level block here represents a series of permanently interconnected functions which you need to configure with appropriate parameters. Only then will you be given a meaningful measured value for the three device variables.

Description

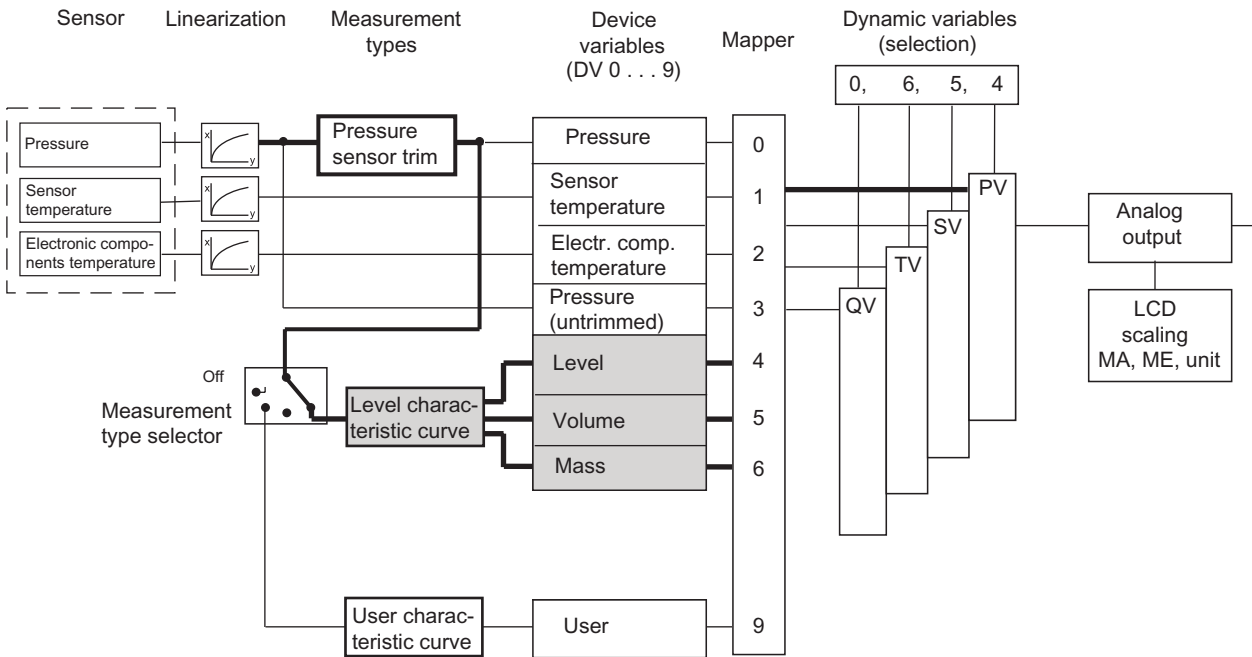

Figure 7-2 Measurement type "Level"

| | | | |
|----|----------------------|----|-------------|
| DV | Device Variable | MA | Zero value |
| PV | Primary Variable | ME | Limit value |
| SV | Secondary Variable | | |
| TV | Tertiary Variable | | |
| QV | Quarternary Variable | | |

The first function, "Input scaling, pressure", sets the pressure range used by the following functions in all three blocks in the same way. Ideally, this range corresponds to the sensor limits of the transmitter that are assumed in a calculation example for all blocks with 0 and 4 bar. However, you can also set a downscaling of e.g. 1:2. This means that 50% of the nominal measuring range, i.e. 2 bar in this example, controls fully 100% of the following characteristic curve.

Use the "Output scaling, level" to set the measuring limits for the measurement type "Level" with a unit from the level range. The parameter settings in the example should be 10 and 20 m. Then, at 0 bar process pressure, 10 m is displayed in DV4 and 20 m at 2 bar. The values for the zero and limit, which are effective for the analog output, are configured in the analog output block.

In the example, the two pairs of values 0%;0% and 100%;100% are configured for the customized characteristic curve, which is also the default setting. This means that the measured value from the pressure scaling is transferred 1:1 in this example.

7.4 Selecting the measurement type

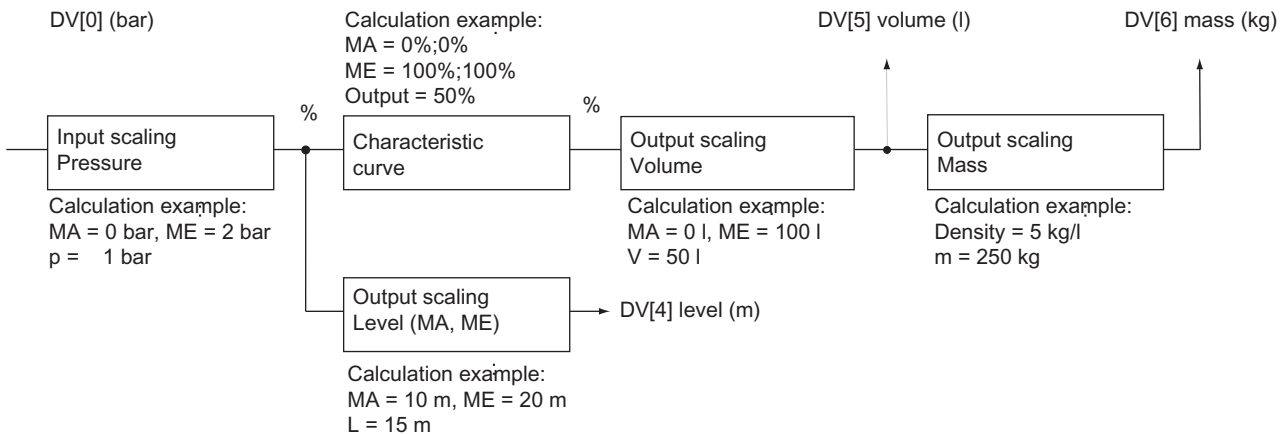

Figure 7-3 Functions of the level block

| | | | |
|--------|-------------------|---|----------|
| DV [x] | Device variable x | m | Mass |
| MA | Zero value | p | Pressure |
| ME | Limit value | V | Volume |
| L | Level | | |

The "Output scaling, volume" has to be configured with a unit from the volume range and the measuring limits for the device variable "Volume". The characteristic curve output directly affects the volume scaling input here. For an example of the measuring limits from 0 and 100 l, a volume of 50 l is yielded for process pressure of 1 bar.

The "Level" parameter setting also still automatically activates the device variable for the mass. If you have not yet configured a value for the density, the initial value of 1 kg/l is preset. With a value of 5 kg/l, a mass value of 250 kg is yielded in the example for the device variable "Mass".

Note

When the density changes, the measuring range limits have to be adjusted accordingly.

You can carry out all parameter settings for the level block in SIMATIC PDM or in the HART Communicator by activating the measurement type "Level" there. For all settings, the measuring limits may be exceeded here as well by +/-20%. Values which lie above or below that will be rejected by the device.

7.4.7 Measurement type "User"

Introduction

The "User" measurement type is the simplest of the measurement types that you can select with the measurement type selector. Only one further device variable, "User", is activated here in addition to the four standard device variables. The variables "Level", "Volume",

"Mass", "Volume of flow" and "Mass of flow" are marked as inactive and are given the status CONSTANT.

Description

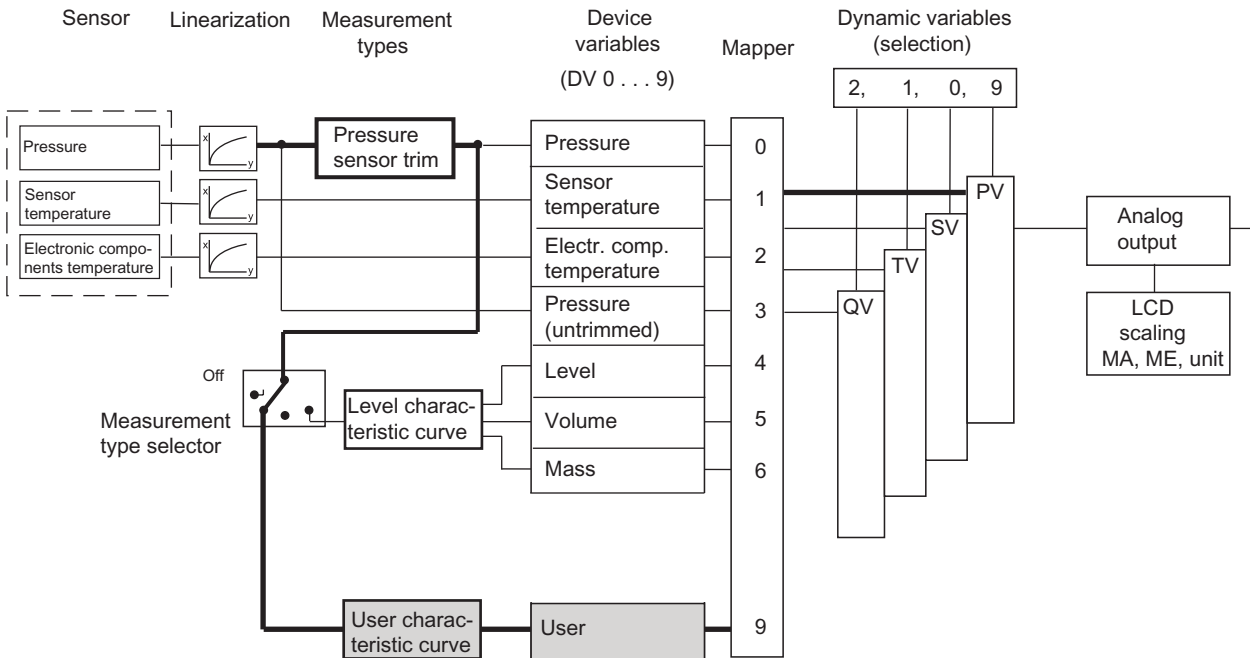

Figure 7-4 Measurement type "User"

| | | | |
|----|----------------------|----|-------------|
| DV | Device Variable | MA | Zero value |
| PV | Primary Variable | ME | Limit value |
| SV | Secondary Variable | | |
| TV | Tertiary Variable | | |
| QV | Quarternary Variable | | |

The first function, "Input scaling, pressure", defines here too the pressure range which is used by the customized characteristic curve. Ideally, this range corresponds to the sensor limits. In the calculation example, 0 and 2 bar are assumed. This means that with process pressure of 0.5 bar, there is an input value of 25% on the characteristic curve.

7.4 Selecting the measurement type

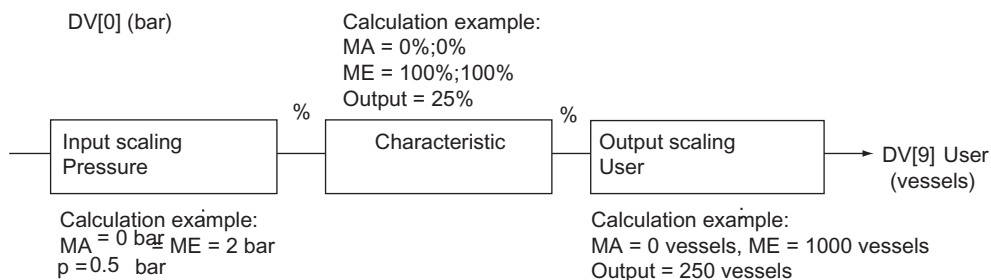

Figure 7-5 Functions of the user block

| | | | |
|--------|-------------------|----|-------------|
| DV [x] | Device variable x | MA | Zero value |
| p | Pressure | ME | Limit value |

In the example, the two pairs of values 0%;0% and 100%;100% are configured for the customized characteristic curve. Any curve forms can be calculated here using 30 vertices and then stored in the device via SIMATIC PDM or the HART Communicator. In the calculation example, the value at the characteristic curve input point is transferred 1:1 to the output point.

A number of filled vessels has to be set for the output scaling. You can enter five characters/digits here for any given unit. Do not confuse this with the user-programmable display unit of the "Analog output" block. With a zero point of 0 vessels and a limit point of 1000 vessels, a value of 250 vessels is yielded in the example for the "User" device variable at a process pressure of 0.5.

See also

- Measured value status (Page 7-10)
- Analog output block (Page 7-13)

7.4.8 Measured value status

Introduction

Every device variable is assigned a status byte, to indicate the quality of the measured values. This status byte can take on the states BAD, GOOD, MANUAL, UNCERTAIN. The identifiers CONSTANT, HIGH LIMIT or LOW LIMIT are possible as well. A higher-level diagnosis program can display and analyze these states.

Description

During smooth, uninterrupted operation, the measured value status of all active device variables is in the state GOOD. All inactive device variables are in the state CONSTANT/BAD. If a pressure value exceeds or falls below the sensor limits of the device by more than 20%, the corresponding measured value and the variables inferred from it are UNCERTAIN. A measured value becomes BAD, on the other hand, when a variable with status BAD was the initial value for the calculation. The basic measured values for pressure and the temperatures become BAD if e.g. the analog-to-digital converter is not working or

the linearization values in the EEPROM are faulty. The same applies if the two end points of the customized characteristic curve are exceeded for the status of the device variables of the following function. If the analog-to-digital converter is put into overrange or underrange, the identifiers HIGH LIMIT and LOW LIMIT are applied.

If the analog-to-digital converter is in overrange or underrange during pressure control, this causes the status UNCERTAIN.

If the status of a device variable changes and it was right at the front of the sequence of operations for a block, e.g. pressure, then all variables that are derived from it will take on the same status. In the following example, the device variable "Pressure" has the status BAD. Since the measurement type selector is set to "USER", the device variable "User" is also given the status BAD.

The reasons for changes to the status of a device variable are summarized in the table. If there were several reasons for a change in status, MANUAL always has the highest priority. BAD follows as next highest and UNCERTAIN as the third highest priority.

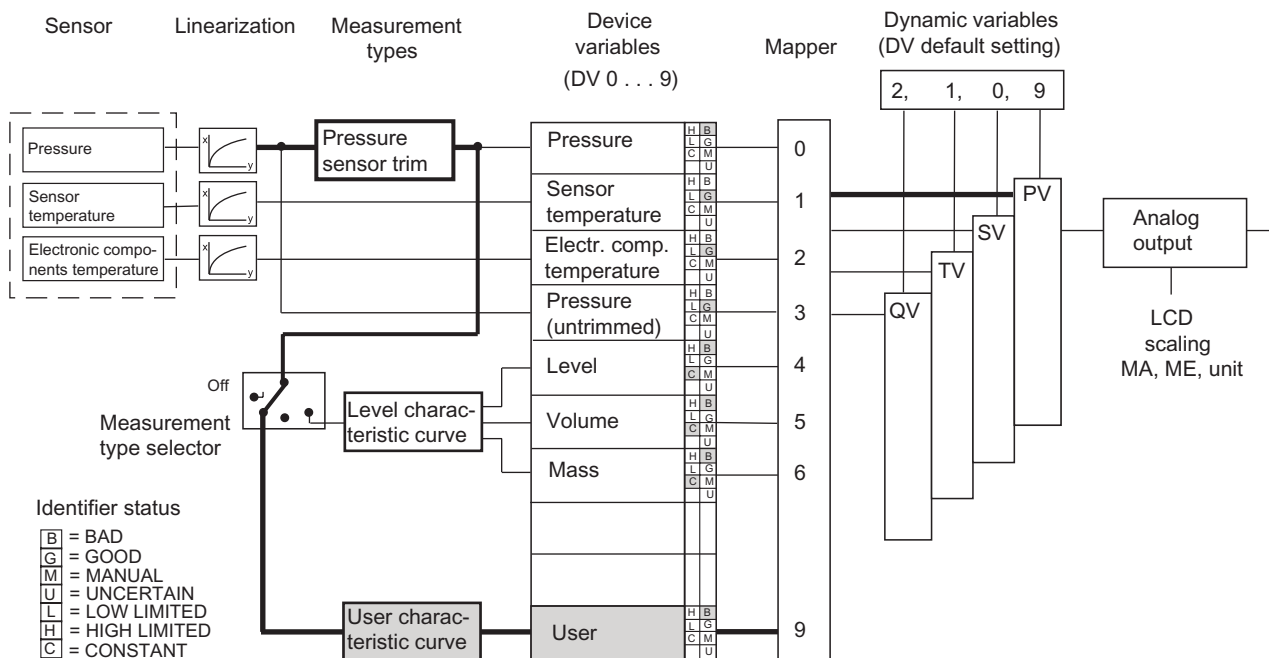

Figure 7-6 Device status dependency

- | | | | |
|----|----------------------|----|-------------|
| DV | Device Variable | MA | Zero value |
| PV | Primary Variable | ME | Limit value |
| SV | Secondary Variable | | |
| TV | Tertiary Variable | | |
| QV | Quarternary Variable | | |

7.4 Selecting the measurement type

Table 7-1 Events which result in a change of status

| DV | Measurement type | BAD | MANUAL | UNCERTAIN | CONSTANT | HIGH LIMIT | LOW LIMIT |
|----|--|---|-----------------------|--|---|--|---|
| 0 | Pressure | DV3=BAD, fault in linearization | When DV0 is simulated | DV3 = UNCERTAIN | - | DV3 = HIGH LIMIT | DV3 = LOW LIMIT |
| 1 | Sensor temperature | DV2 = BAD, analog-to-digital converter in over/underrange , fault in linearization | When DV1 is simulated | DV1 more than 20% outside the sensor limits DV2= UNCERTAIN DV2 = MANUAL | - | Analog-to-digital converter in overrange | Analog-to-digital converter in underrange |
| 2 | Electronics temperature | Analog-to-digital converter in over/underrange , fault in linearization | When DV2 is simulated | DV2 more than 20% outside the sensor limits | - | Analog-to-digital converter in overrange | Analog-to-digital converter in underrange |
| 3 | Pressure (untrimmed) | Analog-to-digital converter in over/underrange , sensor breakage DV1, DV2=BAD, fault in linearization | - | Analog-to-digital converter in overrange/underrange, DV3 more than 20% outside the sensor limits DV2 = MANUAL | - | Analog-to-digital converter in overrange | Analog-to-digital converter in underrange |
| 4 | Level | If DV0 = BAD | When DV0 is simulated | DV0= UNCERTAIN | DV not active | DV0 = HIGH LIMIT | DV0 = LOW LIMIT |
| 5 | Volume | DV0 = BAD Characteristic curve is faulty | When DV0 is simulated | DV0= UNCERTAIN Input value is outside the specified characteristic curve range | Characteristic curve is faulty DV not active | DV4 = HIGH LIMIT Characteristic curve for maximum value with gradient 0 | DV4 = LOW LIMIT Characteristic curve for minimum value with gradient 0 |
| 6 | Mass | DV5 = BAD | When DV0 is simulated | DV5= UNCERTAIN | DV not active, DV5=CONSTANT | DV5 = HIGH LIMIT | DV5 = LOW LIMIT |
| 7 | Volume of flow (not absolute and gauge pressure) | DV0 = BAD Characteristic curve is faulty | When DV0 is simulated | DV0= UNCERTAIN Input value is outside the specified characteristic curve range | Characteristic curve is faulty, DV not active | DV4 = HIGH LIMIT Characteristic curve for maximum value with gradient 0 | DV4 = LOW LIMIT Characteristic curve for minimum value with gradient 0 |
| 8 | Mass flow rate (not absolute and gauge pressure) | DV5 = BAD | When DV0 is simulated | DV5= UNCERTAIN | DV not active DV5 = CONSTANT | DV5 = HIGH LIMIT | DV5 = LOW LIMIT |

| DV | Measurement type | BAD | MANUAL | UNCERTAIN | CONSTANT | HIGH LIMIT | LOW LIMIT |
|----|------------------|---|-----------------------|---|---|--|---|
| 9 | Users | DV0 = BAD Characteristic curve is faulty | When DV0 is simulated | DV0= UNCERTAIN Input value is outside the specified characteristic curve range | Characteristic curve is faulty DV not active | DV0 = HIGH LIMIT Characteristic curve for maximum value with gradient 0 | DV0 = LOW LIMIT Characteristic curve for minimum value with gradient 0 |

If falling characteristic curves are being used in the blocks, the meanings of HIGH LIMIT and LOW LIMIT are swapped around.

If you mix falling and rising characteristic curves, the meanings will be swapped each time a falling characteristic curve is run.

7.4.9 Analog output block

Introduction

The analog output block converts the value provided by the dynamic Primary Variable (PV) into a current value of 4 to 20 mA. When you actuate the measurement type selector, you automatically define the zero point and limit point to the current values 4 and 20 mA, respectively. By default, the limit values of the corresponding device variables, as entered by you when setting your measurement type, will be used for scaling the analog output.

Example for measurement type "Level"

This means that for a "Level" device variable as PV, 10 m corresponds to the value for 4 mA and 20 m corresponds to the value for 20 mA. You can change this setting again in the analog output block. This is done by restricting the range of the "Level" device variable for scaling the output current to e.g. 12 to 18 m. This downscaling has no effect on the previous block scaling. In this case, a current of 4 mA is output for a measured height of 12 m, and a current of 20 mA for 18 m.

Operating functions via HART
 7.4 Selecting the measurement type

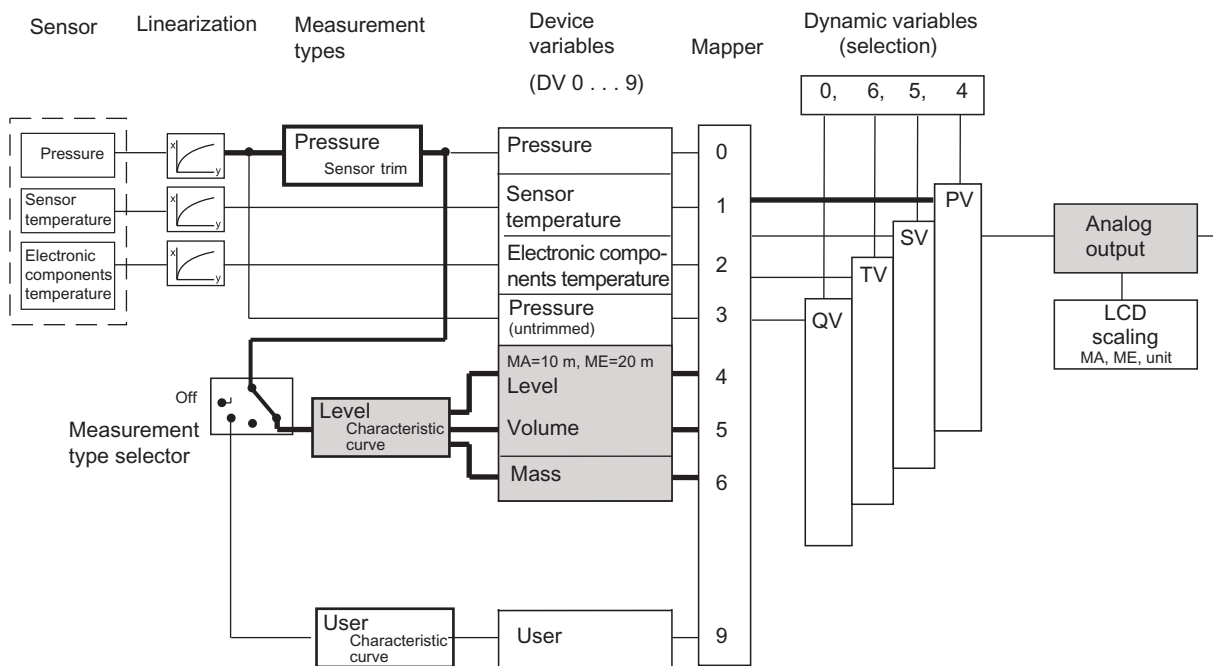

Figure 7-7 Analog output scaling

- | | | | |
|----|----------------------|----|-------------|
| DV | Device Variable | MA | Zero value |
| PV | Primary Variable | ME | Limit value |
| SV | Secondary Variable | | |
| TV | Tertiary Variable | | |
| QV | Quarternary Variable | | |

Description of measurement type "Level"

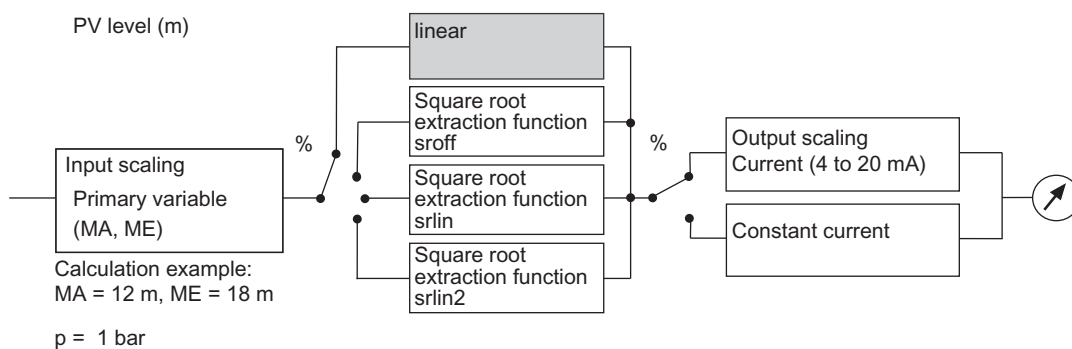

Figure 7-8 Analog output block

- | | | | |
|----|-------------|---|----------|
| MA | Zero value | p | Pressure |
| ME | Limit value | | |

Note

If, when setting the analog output, the values for zero point and limit point are more than 20% below or above the limit values of the set PV (set using the mapper), the values will be rejected by the device. The values configured previously are retained. Similarly, the span must not fall below the minimum.

Minimum span = Limit point - Zero point

The square root extraction function can only be selected in the "Pressure" measurement type.

7.4.10 Scaling of the digital display value

Introduction

Regardless of the setting of the measurement type selector, the Primary Variable (PV) and the display unit defined with the PV, you can scale the value shown on the digital display as desired and allocate it any unit of 5 characters. To do so, use the Digital Display Settings item in SIMATIC PDM or in the HART Communicator.

This scaling is based on the percentage value of the PV, which is also used for scaling the current output. In other words, set the output scaling PV in SIMATIC PDM. After selecting the Digital Display Settings menu command, you need to enter a start value, an end value and a unit string.

This display selection takes priority over all other possible options. Conversion to%, mA or another unit is not possible in this state. To do that, you need to switch the LCD scaling off again.

Example

In the example, zero point with 0 m and limit point with 10 m are assumed in measurement type "Level". With a process pressure of 0.4 bar, 2 m is displayed.

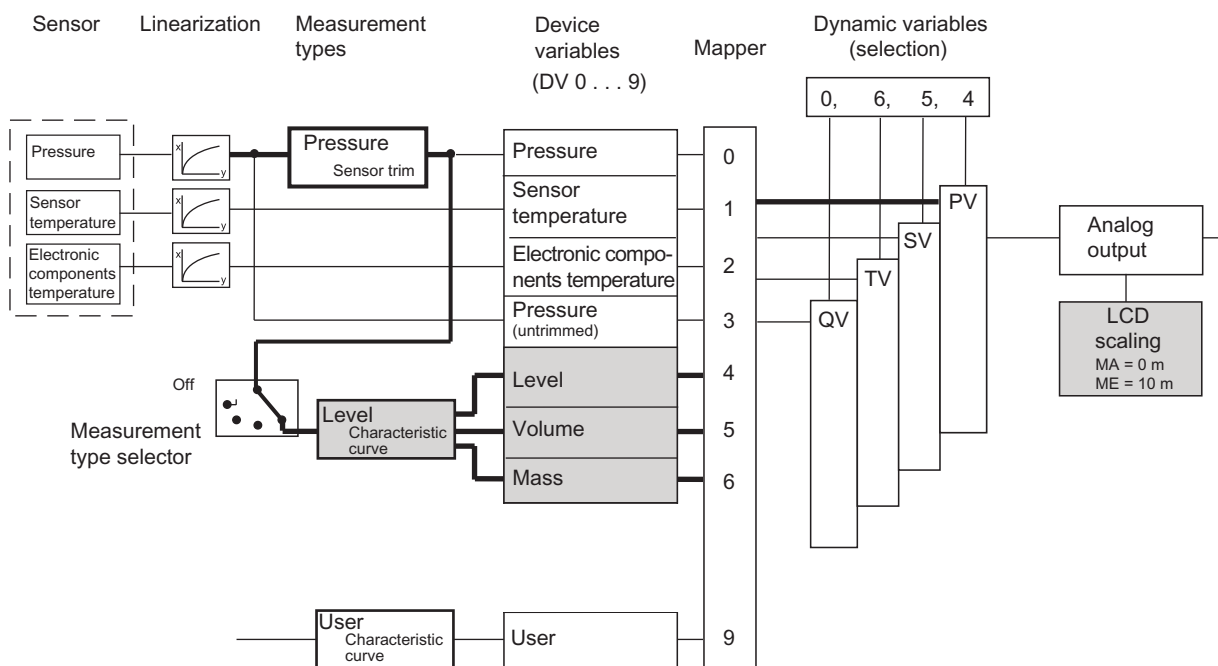

Figure 7-9 Free LCD scaling

- | | | | |
|----|----------------------|----|-------------|
| DV | Device Variable | MA | Zero value |
| PV | Primary Variable | ME | Limit value |
| SV | Secondary Variable | | |
| TV | Tertiary Variable | | |
| QV | Quarternary Variable | | |

7.5 Setting zero point and limit point

You can set the zero point and the limit point using the SIMATIC PDM or HART Communicator. You can use this function to realize rising or falling characteristic curves. The pressure unit can be set separately for the display and for HART communication.

See also

The difference between setting and adjusting (Page 6-13)

7.6 Blind setting of zero point and limit point

- Zero point and limit point can be set without creating a reference pressure.
- Both values can be selected as any point within the sensor limits.
- The maximum downscaling is 1:100, depending on model and measuring range.

7.7 Zero point calibration (position correction)

Description

A zero point calibration is used to correct a zero point error resulting from the installation position.

Procedure

- Pressurize the device (Pressure, Level) or evacuate it (Absolute pressure, <0.1 ‰ of the measuring span).
- Perform the zero point calibration using SIMATIC PDM or the HART Communicator.
- If you do not have a vacuum, perform a trimming of the lower sensor trim point for a known reference pressure.



Caution

For absolute pressure transmitters, the zero point is at vacuum. A zero point calibration with a pressurized transmitter will lead to faulty settings!

Note

The effective measuring range is reduced by the amount of the upstream pressure.

Example:

With an upstream pressure of 100 mbar, the effective measuring range of a 1-bar transmitter is reduced to a point between 0 and 0.9 bar.

See also

Trimming of the sensor trim point (Page 7-23)

7.8 Electrical damping

Description

You can set the time constant of electrical damping to a point within a range from 0 to 100 s. It always applies to the "Pressure" device variable (DV0) and thus to the measured values derived from it.

7.9 Fast response mode

Description

This mode is only intended for special applications such as fast recognition of jumps in pressure, e.g. pressure drop in the event of pipe breakage. The internal recording of measured values is sped up at the cost of accuracy. From your point of view, an increased low-frequency noise is caused for the measured value. For this reason, good accuracy can only be achieved by setting the measuring span to the maximum.

7.10 Current sensor

Description

The transmitter can be switched to constant current operation for test purposes. In that case, the current no longer corresponds to the process variable. A "C" appears in the mode display of the digital display.

7.11 Fault current

Description

You can use this function to set the size of the lower (<4 mA) and upper (>20 mA) fault current. Both signal a hardware/firmware fault, sensor breakage, or that the alarm limit has been reached (diagnostic interrupt). In that case, ERROR appears in the digital display. You can obtain a detailed guide to the display using SIMATIC PDM or the HART Communicator.

Reference

NAMUR recommendation NE43 of Jan 18 1994:

"Standardization of the signal level for the breakdown information of digital transmitters with analog output signal"

See also

Error display (Page 6-6)

7.12 Setting the current limits

Description

The level of the upper and lower fault current and the upper and lower saturation limits can be freely selected within the preset limits of the current output signal.

The specified accuracy of the current output signal is only valid within the current limits 4 to 20 mA.

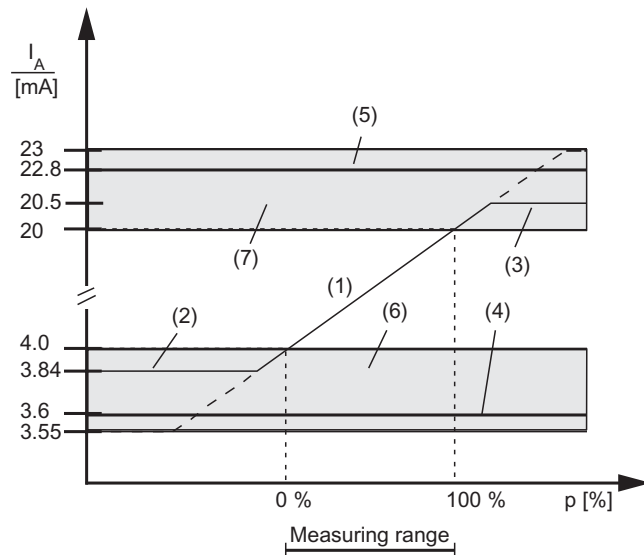

Figure 7-10 Current limits

- (1) Linear control range
- (2) Lower saturation limit (default value)
- (3) Upper saturation limit (default value)
- (4) Lower fault current value (default value)
- (5) Upper fault current value (default value)
- (6) Recommended setting range for lower fault current range and lower control range limit
- (7) Recommended setting range for upper fault current range and upper control range limit

7.13 Key lock and write protection

Introduction

You can use this function to lock the keys or activate write protection to safeguard the saved parameters.

Lock options

You have the following lock options on the pressure transmitter:

Table 7-2 Meaning of the HART lock modes

| Lock mode | Meaning |
|-----------|--|
| 0 | The device can be operated by means of the keys and HART communication. |
| LA | Keys on the transmitter are locked. Exception: <ul style="list-style-type: none">• Releasing key lock The device can be operated by means of HART communication. |
| LO | Keys on the transmitter are partially locked. Exception: <ul style="list-style-type: none">• Setting zero point• Releasing key lock The device can be operated by means of HART communication. |
| LS | Keys on the transmitter are partially locked. Exception: <ul style="list-style-type: none">• Setting zero point• Setting limit point• Releasing key lock The device can be operated by means of HART communication. |
| LL | Write protection You can now only release the lock using HART communication. |

See also

Locking keys (Page 6-29)

Releasing key or function lock (Page 6-30)

7.14 Measured value display

Introduction

You can use this function to set one of three options for the device display:

- Display in mA
- Display in % (of the set measuring range)
- Display in terms of a physical unit, e.g. bar, l, m³/h etc.

Description

If the Primary Variable is mapped to the "Pressure" device variable, you can configure the displayed pressure unit with an add-on, GAUGE (G) or ABS (A). The add-on has no effect on the real measured value.

To do so, select the option Gauge or Absolute under the "Pressure display type" menu command.

There are two options for the display:

- If the pressure unit is < 5 characters, an A or a G is added at the end, respectively.
- If the pressure unit is ≥ 5 characters, the letters GAUGE or ABS flash alternately with the pressure unit.



Figure 7-11 Add-on with example GAUGE

Note

The change of the display with GAUGE or ABS does not change the physical pressure used by the transmitter, rather only the nature of the display.

See also

Measured value display (Page 6-32)

7.15 Selection of the physical unit

Introduction

You can use this function to select a unit from a table with predefined units.

Description

The only units available will be those of the device variable that was mapped as the Primary Variable (PV).

The unit can be set separately for the display and for HART communication. You can also choose to link the setting of the two units.

See also

Unit (Page 6-33)

7.16 Bar graph

Description

You can use this to switch on the "Bar graph" function in the device display, so that it alternates with the unit display. When the device is delivered, the "Bar graph" function is switched off.

See also

Elements of the digital display (Page 6-4)

7.17 Sensor trim

7.17.1 Sensor trim

Description

The sensor trim can be used to set the characteristic curve of the transmitter at two sensor trim points. The results are then correct measured values at the sensor trim points. The sensor trim points can be selected as any points within the nominal range.

Devices that are not turned down prior to delivery are trimmed at 0 bar and the upper limit of the nominal range; devices that are turned down prior to delivery are trimmed at the lower and upper limits of the set pressure measuring range.

Application examples

1. For a particular device that is not turned down (e.g. 63 bar), the typical measured value is 50 bar. To attain the highest possible accuracy for this value, perform the upper sensor trim at 50 bar.
2. A 63-bar transmitter is turned down to 4 to 7 bar. You can attain the highest possible accuracy by selecting 4 bar for the lower sensor trim point and 7 bar for the upper.
3. A 250-mbar absolute pressure transmitter shows 25 mbar at 20 mbar (abs). A reference pressure of 100 mbar is available. You can carry out zero point correction by performing a lower sensor trim at 100 mbar.

Note

The accuracy of the test device should be three times as high as that of the transmitter.

7.17.2 Trimming of the sensor trim point

Trimming the lower sensor trim point

The pressure at which the lower sensor trim is to be performed is applied at the transmitter. Via SIMATIC PDM or the HART Communicator, you instruct the transmitter to accept this pressure.

This represents an offset shift of the characteristic curve.

Trimming the upper sensor trim point

The pressure at which the upper sensor trim is to be performed is applied at the transmitter. Via SIMATIC PDM or the HART Communicator, you instruct the transmitter to accept this pressure.

A gradient correction is thereby applied to the characteristic curve. The lower sensor trim point is not affected by this. The upper trim point needs to be greater than the lower trim point.

7.18 Current sensor trim

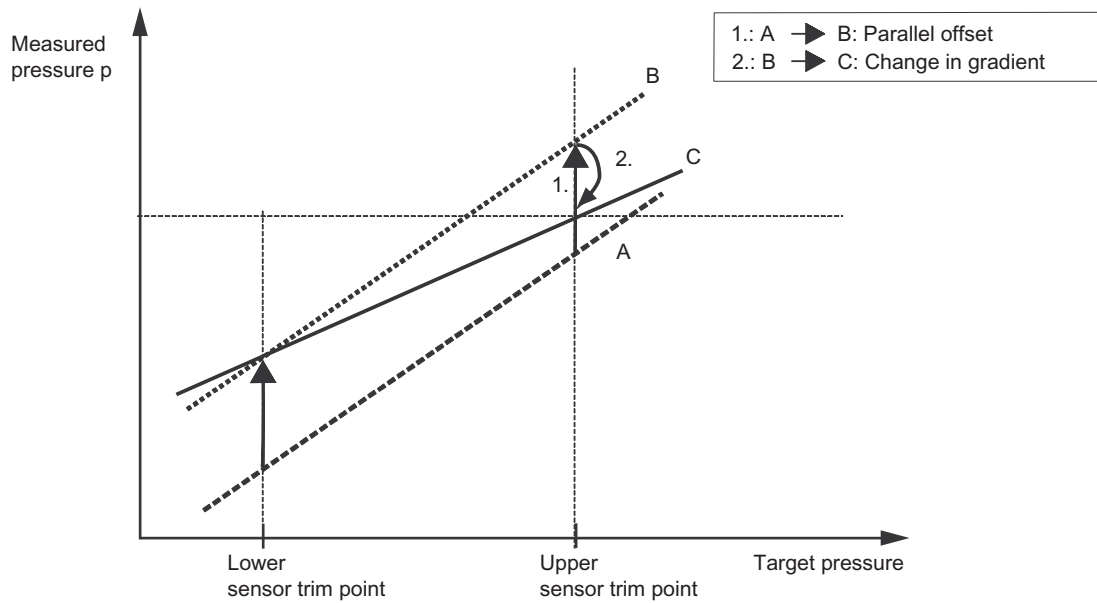

Figure 7-12 Sensor trim

- A Output curve
- B Characteristic curve after lower sensor trim
- C Characteristic curve after upper sensor trim

7.18 Current sensor trim

Description

The current that is output by the transmitter can be trimmed independently of the pressure measuring circuit. This function is designed for compensating inaccuracies in the processing chain following the transmitter.

Example of an application

The current is to be measured as a voltage drop from 1 to 5 V at a resistance of 250 Ohm +/- 5%. To trim the tolerance of the resistance, set the current sensor so that the voltage drop at 4 mA is exactly 1 V and at 20 mA is exactly 5 V.

1. Trim at 4 mA:

Use the current sensor trim menu option to instruct the transmitter to output 4 mA. Read the measured value from the ammeter and enter it, via SIMATIC PDM for example. The transmitter uses this value for offset correction of the current.

2. Trim at 20 mA:

Use the current sensor trim menu option to instruct the transmitter to output 20 mA. Read the measured value from the ammeter and enter it, via SIMATIC PDM for example. The

transmitter uses this value for gradient correction of the current. The value for 4 mA is not affected by this.

Note

If a multimeter is used, it must always be sufficiently accurate.

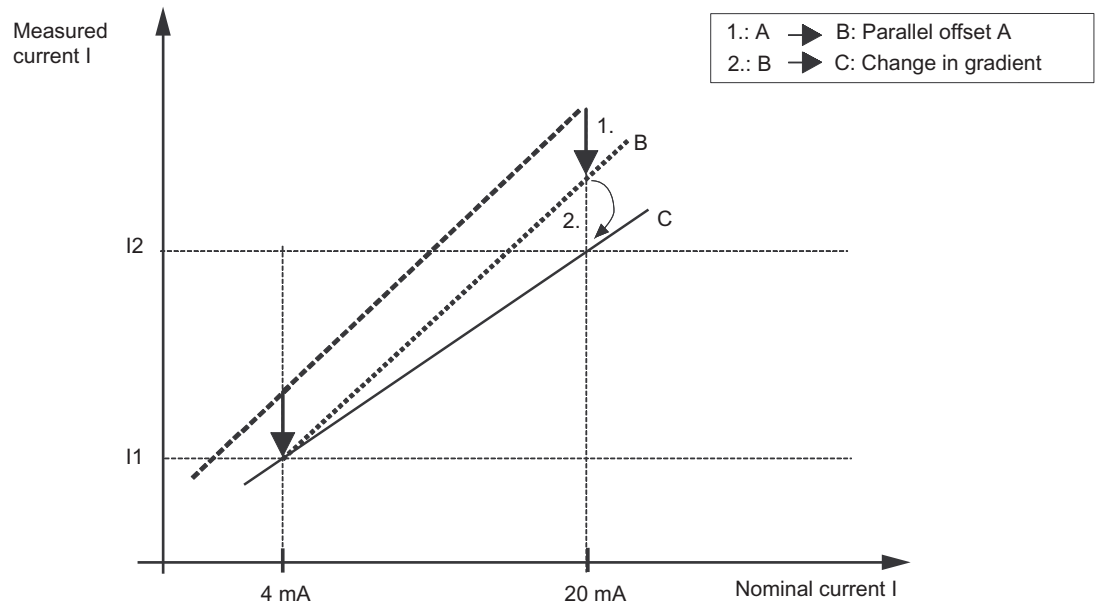

Figure 7-13 Current sensor trim

- A Output curve
- B Characteristic curve after current sensor trim 4 mA
- C Characteristic curve after current sensor trim 20 mA

7.19 Factory calibration

Introduction

You can use factory calibration to reset the transmitter to the factory state.

Description

You can use the menu-guided interface of SIMATIC PDM or HART Communicator to select the range of parameters to be reset:

1. Current trim
2. Sensor zero point calibration (position correction)
3. Pressure corrections (zero point calibration and sensor trim)
4. All parameters relevant for the processing of measured values, such as zero point, limit point, electrical damping, display unit, current trim, zero point calibration (position correction), sensor trim, measuring speed, interrupt current limits, interrupt setting, overflow ranges of current.
5. Variable mapper. This performs the following setting:
PV= Pressure, SV= Sensor temp., TV= Electronics temp., QV= Non-linearized pressure

PV Primary Variable
SV Secondary Variable
TV Tertiary Variable
QV Quarternary Variable

7.20 Static configuration data

Description

A further menu command in the corresponding operating program allows you to read and also write a series of sensor-specific material data. With the factory state, this data is pre-allocated according to the particular device model. These values are not contained in the "Factory calibration" function; in other words, changes in the device are permanently saved.

List of variable material parameters:

- Flange type
- Flange material
- Remote seal type
- Filling medium
- O-ring material
- Remote seal
- Remote seal diaphragm material
- Number of remote seals
- Sensor filling medium
- Sensor seal diaphragm material
- Transmitter model
- Casing material

- Tube length
- Process connection
- Electrical connection

For a series of these material data items, you can enter any designation of your choice under the option "Special". This applies to the following parameters:

- Process connection
- Flange type
- Remote seal type
- Remote seal
- Diaphragm material
- Remote seal filling medium

You can use up to 16 characters for each entry.

7.21 Diagnostic functions

7.21.1 Overview

Description

HART communication allows you to activate and evaluate a wide range of diagnostic functions from a central control room or onsite:

- Calibration/service timer
- Min/max pointer
- Limit monitoring modules
- Simulation of measured pressure and temperature values
- Limit monitoring of all device variables

The diagnostics strategy employed for SITRANS P300 incorporates a diagnostic warning and a diagnostic interrupt for diagnostic functions for monitoring limit values, e.g. for monitoring current saturation. This warning and interrupt can be configured:

- Diagnostic warning: The device transmits via HART communication the diagnostic event that has occurred. The current output value is unaffected. The message "Diagnostic Warning" alternates with the unit on the display.
- Diagnostic interrupt: The device goes into the fault current state. The message "Diagnostic Warning" or "Diagnostic Alarm" appears on the display, along with the message ERROR. In addition, the diagnostic event is made available via HART communication.

In the default settings, all warnings and alarms are switched off. You can choose to set either the diagnostic warning only or the diagnostic interrupt and warning. For HART communication, use the HART Communicator or PC software such as SIMATIC PDM. To

see the steps required, refer to the attached table for operation of the HART Communicator or the help functions in the SIMATIC PDM software.

7.21.2 Operating hours counter

Description

An operating hours counter can be read via HART communication for the electronics and another for the sensor. For HART communication, use the HART Communicator or PC software such as SIMATIC PDM. The counters are activated the first time the transmitter is put into operation. If the device is separated from its power supply, the counter readings are automatically stored in the non-volatile memories. That means that the current counter readings can be accessed at the next restart. The operating hours counters cannot be reset.

7.21.3 Calibration timer and service timer

Description

To guarantee regular calibration of the electronics and for servicing work on the sensor, you can fit a two-stage timer to each. After the first time period has elapsed, a calibration or service warning will be issued. After a second time period, which can be configured as a time differential, a diagnostic interrupt is reported and fault current is output.

To perform calibration work, you need to acknowledge warnings and interrupts. You can then reset the timers and switch off the monitoring function. The calibration intervals for the electronics are calculated using the following formula:

$$\text{Calibration interval} = \frac{\text{required accuracy} - \text{probable total error}}{\text{Stability/month}}$$

For operating/acknowledging the warnings and interrupts in SIMATIC PDM and via the HART Communicator, the following applies:

As long as the warning/interrupt limit has not been reached, the following applies:

- "Reset" resets the timer and starts again from count 0. Monitoring remains active.
- "Acknowledge" has no effect; the timer continues running and monitoring remains active.
- "Reset and deactivate" stops the timer, resets it, and deactivates monitoring.

When the warning/interrupt limit has been reached, the following applies:

- "Acknowledge" resets the warning/interrupt message, but allows the timer to keep running. In this state, a new interrupt or warning is not possible since the time limits have already been exceeded.

- "Reset" resets the warning/interrupt message and the timer. It acknowledges the interrupt or warning at the same time. The timer immediately starts running again from zero and will report again when the warning/interrupt limit is next reached. The next calibration interval is therefore immediately active.
- "Reset and deactivate W/I" resets the warning/interrupt message and the timer and deactivates it.

7.21.4 Min/max pointer

Description

The transmitter provides three min/max pointer pairs, which you can use to monitor the three measured variables Pressure, Sensor temperature, and Electronics temperature for negative and positive peak values. For each measured value, a resettable min/max pointer saves the maximum and minimum peak values in long-term storage in the two non-volatile memories. Consequently, the values are available even after the device is restarted. The min/max pointers are also updated during a simulation.

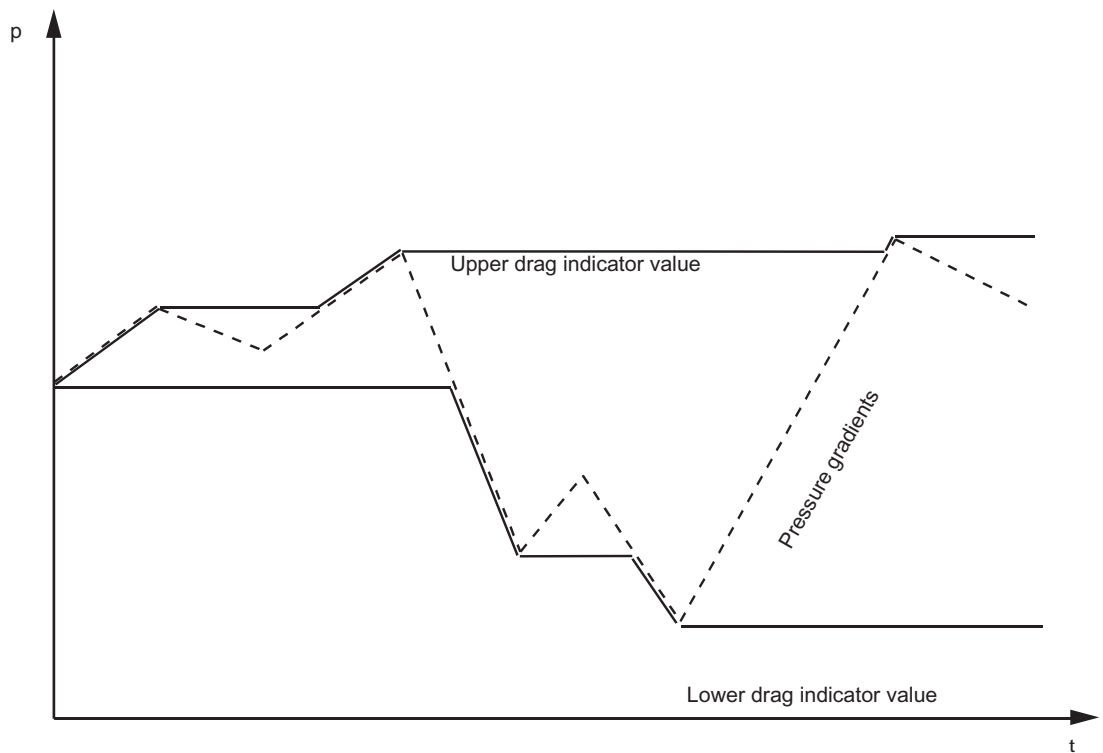

Figure 7-14 Basic representation of min/max pointers

p Pressure t Time

See also

Overview of simulation (Page 7-32)

7.21.5 Limit modules

7.21.5.1 Overview of limit modules

Description

The diagnostic functions of this device provide you with the option of monitoring measured values in limits that can be configured. When the limits are violated, the device warns you via HART communication or reports an analog fault current to a higher-level recipient.

7.21.5.2 Monitoring of current saturation

Description

You can use a simple limit module to monitor the current output in the saturation range. This module is configured and activated via HART communication. For HART communication, use a HART Communicator or PC software such as SIMATIC PDM. You need to configure two time periods. The first time period specifies how long the current output is allowed to be in saturation (response time) before an interrupt is triggered and the device outputs its set fault current. The second time period (stop time) specifies the duration of the interrupt.

In the first example, the response time starts at time t_1 , when the current reaches the programmed saturation limit for the first time. At t_2 the response time ends and the stop time begins. The interrupt is revoked immediately as soon as the programmed stop time has passed (t_3) and the current has gone below the saturation limit again.

In the second example, the duration of the current saturation is shorter than the response time (t_1, t_2). In that case, the device does not go into "fault current" state.

In the third example, the current only exceeds the lower saturation limit for a short time. The fault current is not switched off until after the end of the stop time (t_3).

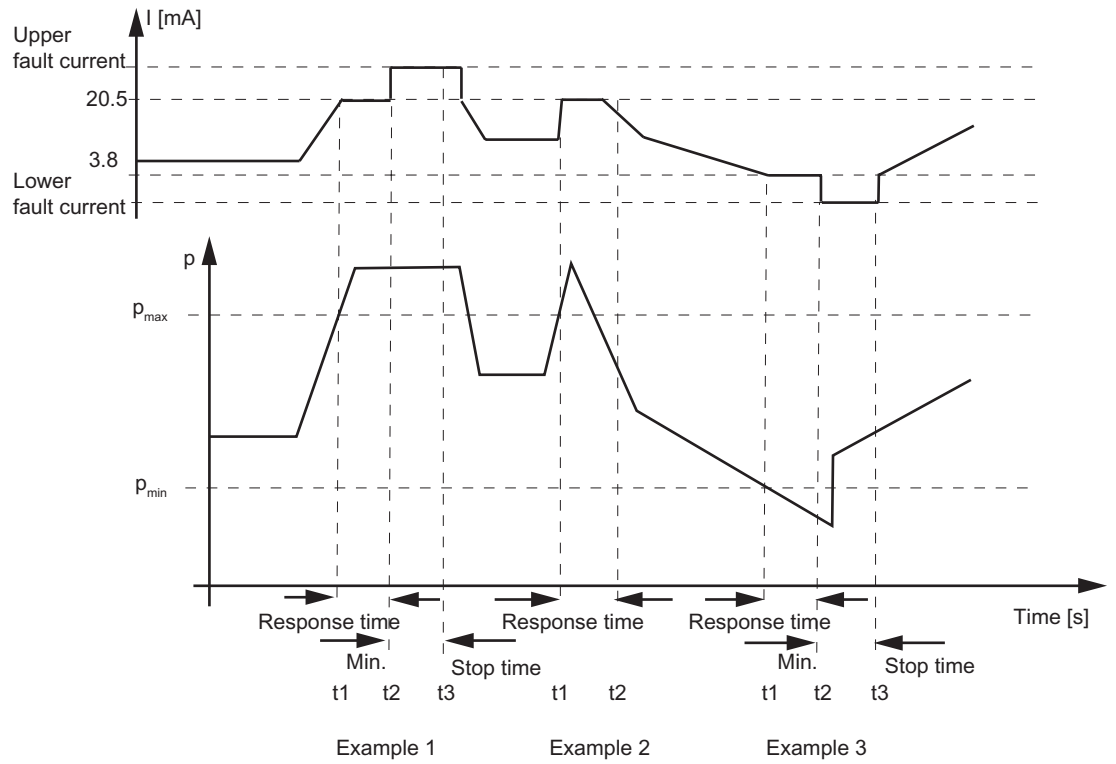

Figure 7-15 Saturation monitoring with saturated interrupt value

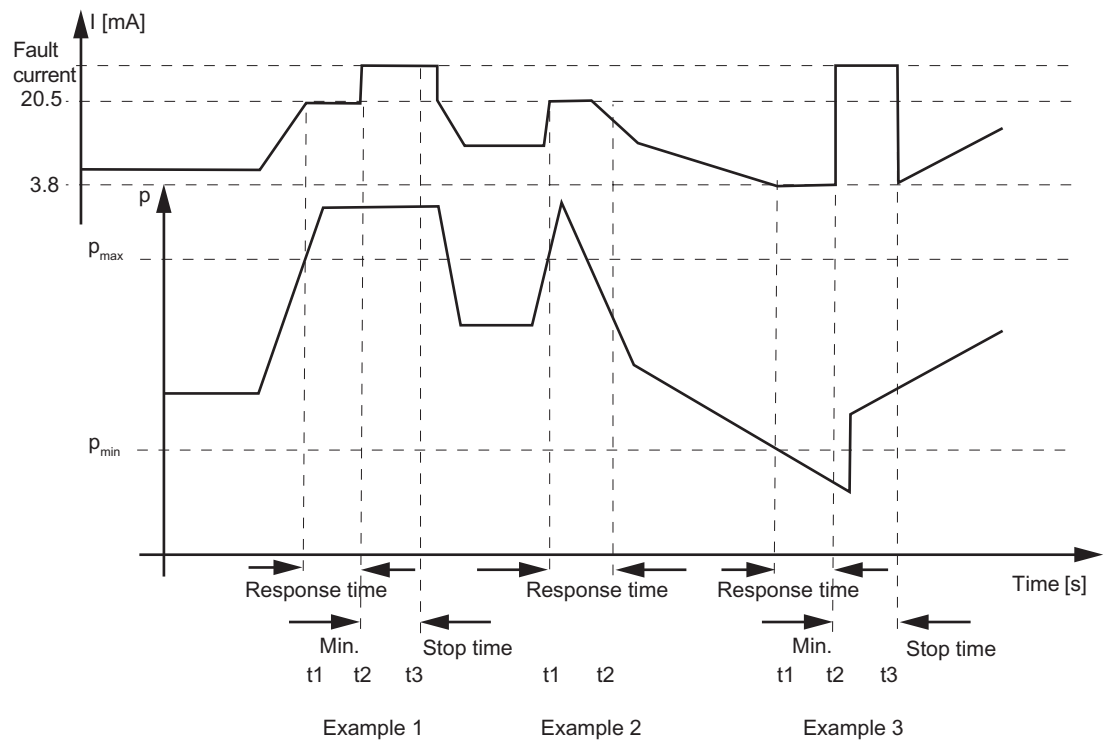

Figure 7-16 Saturation monitoring with active interrupt value at top

The direction of fault current, which is to be selected for a current saturation interrupt, can be programmed according to your needs. The following settings are possible under the current saturation menu:

| | |
|-----------------------------------|---|
| Active interrupt value | The applicable settings are those under the current interrupt type menu command. |
| Inverse interrupt value | The applicable settings are the inverse settings under the current interrupt type menu command. |
| Saturated interrupt value | The fault current is output in the direction of current saturation. |
| Inverse saturated interrupt value | The fault current is output in the opposite direction to current saturation. |

7.22 Simulation

7.22.1 Overview of simulation

Description

With the "Simulation" diagnostic function, you can receive and process (quasi-) measurement data onsite or in the control room without having process pressure or a temperature value. This allows you to run individual process sequences in the "cold" state and thus simulate process states. In addition, if you inject simulation values you can test the line routing from the control room to the individual transmitter.

The value to be simulated can be provided as a fixed value or in the form of a ramp function. Simulation of pressure and temperature values is handled in the same way in terms of parameter settings and function, so the following will only deal with the general simulation procedures "Fixed value" and "Ramp function".

For reasons of safety, all simulation data are held only in the user memory (RAM). This means that when the device is restarted any simulation which may be active will be shut down. You can simulate the pressure and both temperature values. It should be noted here that changing the temperatures by simulation will have no effect on the measured pressure value.

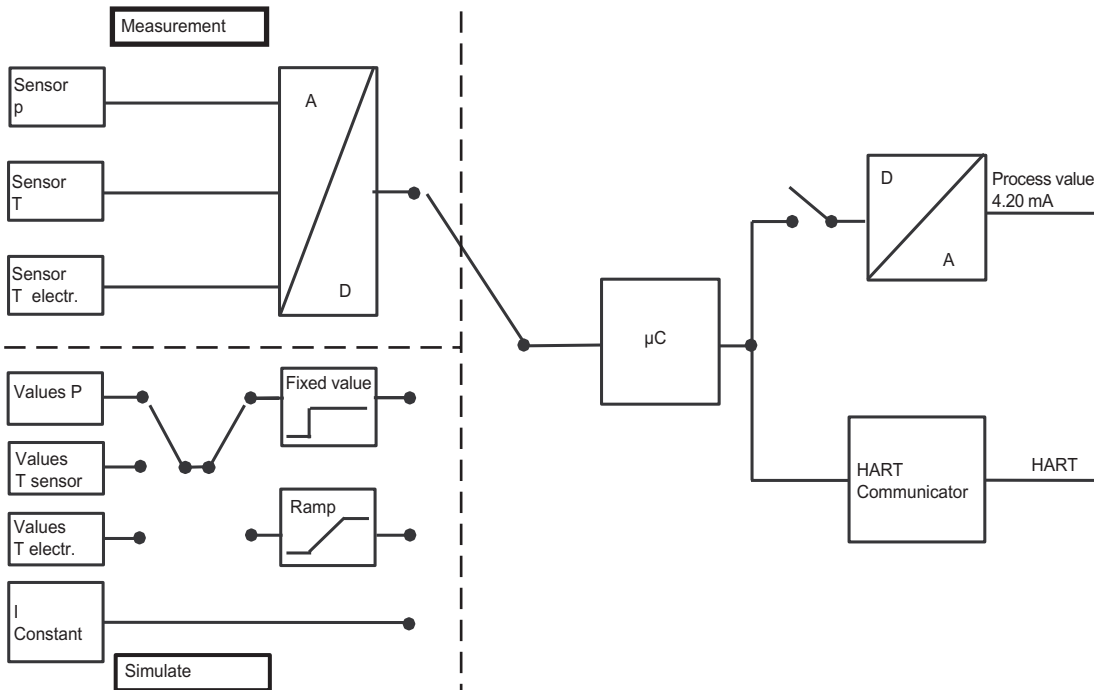

Figure 7-17 Block diagram of simulation

7.22.2 Simulation with a ramp function

Description

In addition to the adjustable fixed values for all three simulation paths, you can, as a second option, also configure one ramp function in each case. Adjustable lower and upper values together determine the limits between which the simulation values with a rising or falling tendency can move. The step width can be calculated with the step number, which is also adjustable. You can specify the rate of rise of the ramp via the duration of the individual ramp steps.

$$\text{Increment} = \frac{\text{Upper range value} - \text{Lower range value}}{\text{Number of steps}}$$

7.22.3 Simulation as fixed value

Description

Taking the physical unit into account you can set a fixed simulation value for all three possible simulation paths. You can simulate the pressure value and both temperature values simultaneously. While pressure simulation is activated, the transmitter will not react to changes in the process pressure. The output value for the current adjusts itself in accordance with the preset pressure value. Simulation of the temperature values has no effect on the current output. It can only be observed via HART communication.

7.23 Limit monitor

Description

You can activate up to three limit monitors in order to monitor any of the device variables. The limit monitor monitors a value at an upper or lower limit value. If this limit is violated it sends a diagnostic warning or a diagnostic interrupt. Select the Limit Monitor menu command in SIMATIC PDM or in the handheld Communicator. You can program the following values for each of the three limit monitors:

Table 7-3 Parameter of the limit monitor

| | |
|---------------------------------------|---|
| Monitoring variable | You will be shown a list of the active device variables. This list is independent of the measurement type selected. |
| Limit monitoring: warning / interrupt | Select whether a warning or a warning plus an interrupt should be triggered when a limit is violated. |
| Limit monitoring: upper / lower | Specify here whether a device variable monitors the upper limit, the lower limit, or both limits. |
| Upper limit value | Upper limit value in the unit of the device variable. |
| Lower limit value | Lower limit value in the unit of the device variable. |
| Hysteresis | Operating point for chatter suppression in the case of small pressure changes. |
| Response time | The time which must pass after the limit is violated before this violation is registered. |
| Stop time | The time for which a limit interrupt or warning will always be sustained even when the event which triggered it is no longer present. |

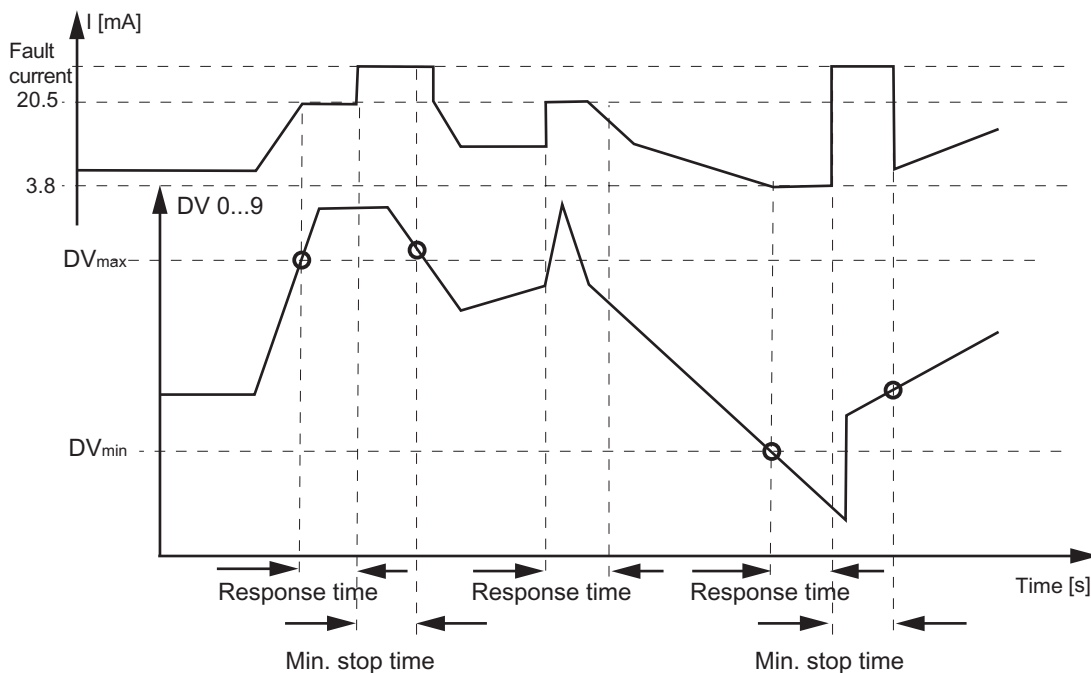

Figure 7-18 Trip levels for the limit monitor

You can count the limit violations for each limit monitor by activating an event counter that provides separate, cumulative totals of upper and lower limit violations. A diagnostic warning and / or a diagnostic interrupt can be issued once a certain number of violations is reached, a number which you can also program. You can program the following values for the event counter:

Table 7-4 Parameters of the event counter

| | |
|--|---|
| Event counter: upper limit | Select here whether a warning or a warning plus an interrupt should be triggered when the comparison value is exceeded. |
| Event counter: lower limit | Select here whether a warning or a warning plus an interrupt should be triggered when the comparison value is not met. |
| Comparison value: upper limit | Specify here the number of overflows at which a warning or a warning plus an interrupt should be triggered. |
| Comparison value: lower limit | Specify here the number of underflows at which a warning or a warning plus an interrupt should be triggered. |
| Limit monitoring, warning/interrupt: upper limit | Select whether a warning or a warning plus an interrupt should be triggered when the event counter upper limit is violated. |
| Limit monitoring, warning/interrupt: lower limit | Select whether a warning or a warning plus an interrupt should be triggered when the event counter lower limit is violated. |
| Reset event counter upper limit | Here you can reset the upper limit counter to zero. A new event is not possible until the counter has been reset. |
| Reset event counter lower limit | Here you can reset the lower limit counter to zero. A new event is not possible until the counter has been reset. |
| Warning/interrupt acknowledgement | Here you can acknowledge each warning or interrupt separately. |

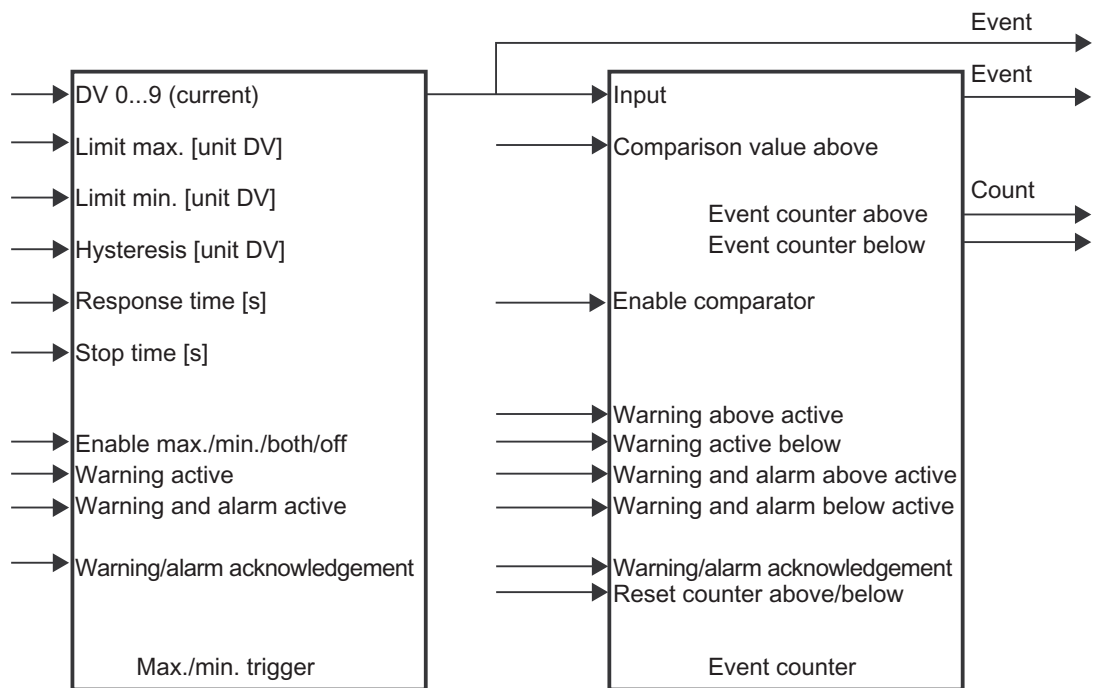

Figure 7-19 Limit monitor and event counter

Messages from the limit monitor and from the event counter can be acknowledged separately. Resetting the event counter starts a new monitoring interval.

Commissioning

8.1 Safety instructions for commissioning



Warning**Intrinsically safe circuits**

With intrinsically-safe circuits, use only certified ammeters appropriate for the transmitter.

Specific type examination certificates

If the transmitter is used in a hazardous area, comply with the EC type examination certificate or the certification valid in your country.



Warning**"Intrinsically safe"**

If a non-conforming supply unit is used, the "intrinsically safe" protection type will no longer be effective and the approval certification will be invalid.



Warning**Fixed installation**

Devices to be operated in hazardous areas should be connected with fixed cable installation. This is not necessary with intrinsically safe devices or devices with "nL" – "limited energy" protection.



Warning**Tightness**

Use cable with a cable diameter of 7 to 12 mm for the IP65 or IP68 protection rating.

Notice

Before commissioning, check the basic parameters.

Due to changes in the operating functions, displays and the measurement output could be set such that the true process pressure is not reproduced.

8.2 Instructions for commissioning

Note

To obtain stable measured values, the transmitter needs to be allowed to warm up for five minutes or so after the power supply is switched on.

Note

The operating data have to correspond to the values on the nameplate. When you switch the auxiliary power on, the transmitter is in operation.

8.3 Introduction to commissioning

Following commissioning, the transmitter is immediately ready for use.

To obtain stable measured values, the transmitter needs to be allowed to warm up for five minutes or so after the power supply is switched on.

The measuring span which can be set corresponds to the information on the nameplate. Even in the case of a customer-specific setting configured in the factory, the zero point and the limit point will appear on the nameplate.

If need be, you can change the parameters by simple user operations on the device even during commissioning.

8.4 Commissioning with steam or liquid

Overview

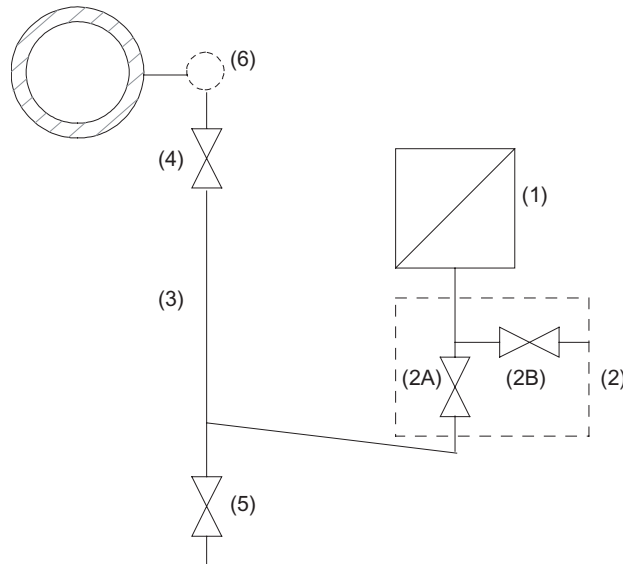

Figure 8-1 Measuring steam

- (1) Pressure transmitter
- (2) Shut-off module
- (2A) Shut-off valve to process
- (2B) Shut-off valve for test connection or for bleed screw
- (3) Pressure line
- (4) Shut-off valve
- (5) Drain valve
- (6) Compensation vessel (steam only)

Requirement

All valves are closed.

Procedure

To commission the transmitter for steam or liquid, proceed as follows:

1. Open the shut-off valve for the test connection (2B).
2. Via the test connection of the shut-off module (2), apply the pressure corresponding to the zero point to the pressure transmitter (1).
3. Check the zero point.
4. If the zero point differs from the value desired, correct it.
5. Close the shut-off valve for the test connection (2B).

- 6. Open the shut-off valve (4) at the pressure tapping point.
- 7. Open the shut-off valve to the process (2A).

8.5 Commissioning for gases

Overview

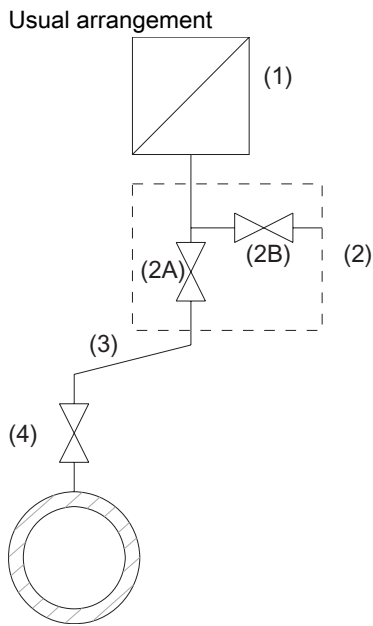

Measuring gases above the pressure tapping point

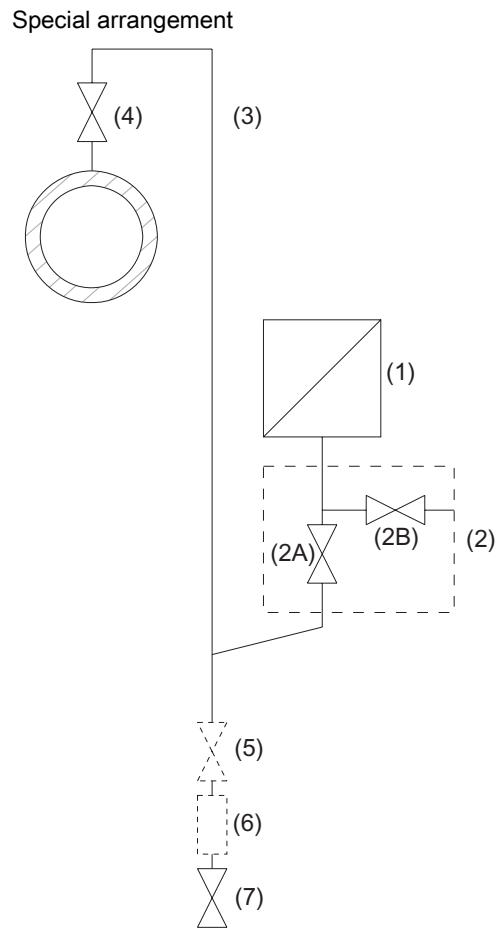

Measuring gases below the pressure tapping point

- (1) Pressure transmitter
- (2) Shut-off module
- (2A) Shut-off valve to process
- (2B) Shut-off valve for test connection or for bleed screw
- (3) Pressure line
- (4) Shut-off valve
- (5) Shut-off valve (optional)
- (6) Condensation vessel (optional)
- (7) Drain valve

Requirement

All valves are closed.

Procedure

To commission the transmitter for gases, proceed as follows:

1. Open the shut-off valve for the test connection (2B).
2. Via the test connection of the shut-off module (2), apply the pressure corresponding to the zero point to the pressure transmitter (1).
3. Check the zero point.
4. If the zero point differs from the value desired, correct it.
5. Close the shut-off valve for the test connection (2B).
6. Open the shut-off valve (4) at the pressure tapping point.
7. Open the shut-off valve to the process (2A).

Specifications

9.1 SITRANS P300 gauge pressure / absolute pressure

Specifications

| Gauge pressure input | |
|--|---|
| Measured variable | Gauge pressure |
| Measuring span | Maximum permissible operating pressure |
| <ul style="list-style-type: none"> 8 ... 250 mbar g (0.12 ... 3.6 psi g) 0.01 ... 1 bar g (0.15 ... 14.5 psi g) 0.04 ... 4 bar g (0.58 ... 58 psi g) 0.16 ... 16 bar g (2.3 ... 232 psi g) 0.6 ... 63 bar g (9.1 ... 914 psi g) 1.6 ... 160 bar g (23.2 ... 2321 psi g) 4.0 ... 400 bar g (58 ... 5802 psi g) | 2 bar g (29 psi g) 4 bar g (58 psi g) 7 bar g (102 psi g) 21 bar g (305 psi g) 67 bar g (972 psi g) 167 bar g (2422 psi g) 400 bar g (5802 psi g) |
| Lower measuring limit | |
| <ul style="list-style-type: none"> Measuring cell with silicone oil Measuring cell with inert liquid | 30 mbar a (0.44 psi a) |
| For process temperature ϑ | |
| -20 °C < ϑ ≤ 60 °C (-4 °F < ϑ ≤ 140 °F) | 30 mbar a (0.44 psi a) |
| For process temperature ϑ | |
| 60 °C < ϑ ≤ 100 °C (140 °F < ϑ ≤ 212 °F) | 30 mbar a + 20 mbar a • (ϑ - 60 °C)/°C (0.44 psi a + 0.29 psi a • (ϑ - 108 °F)/°F) |
| Upper measuring limit | |
| <ul style="list-style-type: none"> Measuring cell with silicone oil Measuring cell with inert liquid | 100% of maximum measuring span 100% of maximum measuring span Max. 160 bar g (2320 psi g) for oxygen measurement |
| Absolute pressure input | |
| Measured variable | Absolute pressure |
| Measuring span | Maximum permissible operating pressure |
| <ul style="list-style-type: none"> 8 ... 250 mbar a (0.12 ... 3.6 psi a) 0.043 ... 1.30 bar a (0.62 ... 19 psi a) 0.16 ... 5 bar a (2.3 ... 73 psi a) | 1.5 bar a (22 psi a) 2.6 bar a (38 psi a) 10 bar a (145 psi a) |

Specifications

9.1 SITRANS P300 gauge pressure / absolute pressure

Absolute pressure input

| | |
|---------------------------------------|--------------------------------|
| • 1 ... 30 bar a (14.5 ... 435 psi a) | 45 bar a (653 psi a) |
| Lower measuring limit | |
| • Measuring cell with silicone oil | 0 mbar a (0 psi a) |
| Upper measuring limit | |
| • Measuring cell with silicone oil | 100% of maximum measuring span |

Output

| | |
|--|---|
| Output signal | 4 ... 20 mA |
| • Lower limit (infinitely adjustable) | Set to 3.84 mA (min. 3.55 mA) |
| • Upper limit (infinitely adjustable) | Set to 20.5 mA (max. 23 mA) |
| • Ripple (without HART communication) | $I_{SS} \leq 0.5\%$ of maximum output current |
| • Electrical damping T_{63} (step width 0.1 s) | Set to 0.1 s (0 ... 100 s) |
| • Current sensor | 3.55 mA ... 23 mA |
| • Failure signal | 3.55 mA ... 23 mA |
| Load | Resistor R [Ω] |
| Without HART communication | $R = \frac{U_H - 10,5 V}{23 \text{ mA}}$ |
| | U_H Auxiliary power |
| With HART communication | |
| • HART Communicator | R = 230 ... 500 Ω |
| • SIMATIC PDM | R = 230 ... 1100 Ω |
| Characteristic curve | Linearly rising or linearly falling |

Measuring accuracy

| | |
|---|---|
| Reference conditions | <ul style="list-style-type: none"> • Rising characteristic curve • Zero point 0 bar • Seal diaphragm: stainless steel • Measuring cell with silicone oil • Room temperature 25 °C (77 °F) • Measuring span ratio r <p style="margin-left: 20px;">r = maximum measuring span or set measuring span</p> |
| Measurement deviation with cut-off point setting, including hysteresis and repeatability. | |
| Linear characteristic curve | |
| • $r \leq 10$ | $\leq (0.0029 \cdot r + 0.071) \%$ |
| • $10 < r \leq 30$ | $\leq (0.0045 \cdot r + 0.071) \%$ |
| • $30 < r \leq 100$ | $\leq (0.005 \cdot r + 0.05) \%$ |
| Settling time T_{63} without electrical damping | approx. 0.2 s |
| Long-term drift at ± 30 °C (± 54 °F) | In 5 years |
| | $\leq (0.25 \cdot r) \%$ |

Measuring accuracy

| | |
|--|---|
| Influence of ambient temperature | As percentage |
| <ul style="list-style-type: none"> at -10 ... +60 °C (14 ... 140 °F) at -40 ... -10 °C and +60 ... +85 °C (-40 ... 14 °F and 140 ... 185 °F) | $\leq (0.1 \cdot r + 0.2) \%$ $\leq (0.1 \cdot r + 0.15) \%$ per 10 K $(\leq (0.1 \cdot r + 0.15) \%)$ per 10 K |
| Influence of installation position | In pressure per change of angle 0.4 mbar (0.006 psi) per 10° Correction via zero point calibration |
| Influence of auxiliary power U_H | In percent per change of voltage 0.005% per 1 V |

Operating conditions

| | |
|--|---|
| Installation conditions | |
| Ambient temperature | |
| Observe the temperature class in areas subject to explosion hazard. | |
| <ul style="list-style-type: none"> Measuring cell with silicone oil Measuring cell with inert liquid Digital display Storage temperature | -40 °C ... +85 °C (-40 °F ... 185 °F) -20 °C ... +85 °C (-4 °F ... 185 °F) -30 °C ... +85 °C (-22 °F ... 185 °F) -50 °C ... +85 °C (-58 °F ... 185 °F) |
| Climatic class | |
| <ul style="list-style-type: none"> Condensation | permitted |
| Degree of protection | IP65, IP68, NEMA 4X, enclosure cleaning, resistant to lyes, steam to 150 °C |
| As per EN 60 529 | |
| Electromagnetic compatibility | |
| <ul style="list-style-type: none"> Spurious emission and resistance to interference | As per EN 61 326 and NAMUR NE 21 |
| Process conditions | |
| Process temperature | |
| <ul style="list-style-type: none"> Measuring cell with silicone oil Measuring cell with inert liquid | -40 °C ... +100 °C (-40 °F ... 212 °F) -20 °C ... +100 °C (-4 °F ... 212 °F) |

Design

| | |
|--|---|
| Weight (without options) | Approx. 800 g (1.8 lb) |
| Material | |
| Wetted parts materials | |
| <ul style="list-style-type: none"> Connection pins Oval flange Seal diaphragm | Stainless steel, mat. no. 1.4404/316L Hastelloy C276, mat. no. 2.4819 Stainless steel, mat. no. 1.4404/316L Stainless steel, mat. no. 1.4404/316L Hastelloy C276, mat. no. 2.4819 |
| Non-wetted parts materials | |

Specifications

9.1 SITRANS P300 gauge pressure / absolute pressure

| Design | |
|--|---|
| • Electronics housing | Electropolished stainless steel, mat. no. 1.4301 |
| Measuring cell filling | <ul style="list-style-type: none">• Silicone oil• Inert liquid |
| Process connection | <ul style="list-style-type: none">• G$\frac{1}{2}$A as per DIN EN 837-1• Internal thread $\frac{1}{2}$-14 NPT• Oval flange PN 160 (MWP 2320 psi) with fastening thread:<ul style="list-style-type: none">– $\frac{7}{16}$-20 UNF as per IEC 61518– M10 as per DIN 19213 |
| Electrical connection | <ul style="list-style-type: none">• Cable entry via threaded connection M20x1.5 (plastic)• Cable entry via threaded connection M20x1.5 (metal with screening) |
| Auxiliary power U_H | |
| Terminal voltage at transmitter | <ul style="list-style-type: none">• DC 10.5 V ... 42 V• In the case of intrinsically safe operation DC 10.5 V ... 30 V |
| Ripple | $U_{SS} \leq 0.2 \text{ V}$ (47 ... 125 Hz) |
| Noise | $U_{eff} \leq 1.2 \text{ V}$ (0.5 ... 10 Hz) |
| Certificates and approvals | |
| Classification according to Pressure Equipment Directive (PED 97/23/EC) | For gases of Fluid Group 1 and liquids of Fluid Group 1; meets requirements of Article 3 Para. 3 (Good engineering practice) |
| Water, waste water | In preparation |
| Explosion protection | |
| Intrinsic safety "i" | PTB 05 ATEX 2048 |
| <ul style="list-style-type: none">• Identification• Permissible ambient temperature | Ex II 1/2 G EEx ia/ib IIB/IIC T4, T5, T6 -40 ... +85 °C (-40 ... +185 °F) Temperature class T4 -40 ... +70 °C (-40 ... +158 °F) Temperature class T5 -40 ... +60 °C (-40 ... +140 °F) Temperature class T6 |
| <ul style="list-style-type: none">• Connection | To certified intrinsically safe circuits with maximum values: $U_i = 30 \text{ V}$, $I_i = 100 \text{ mA}$ $P_i = 750 \text{ mW}$, $R_i = 300 \Omega$ |
| <ul style="list-style-type: none">• Effective inner capacitance:• Effective inner inductance: | $C_i = 6 \text{ nF}$ $L_i = 0.4 \text{ mH}$ |

| Communication | |
|-----------------------|------------------|
| HART communication | 230 ... 1100 Ω |
| Protocol | HART Version 5.x |
| Software for computer | SIMATIC PDM |

See also

SITRANS P300 gauge pressure / absolute pressure (Page 10-1)

9.2 SITRANS P300 gauge pressure / absolute pressure (flush-mounted)**Specifications**

| Input | |
|--|---|
| Measured variable | Gauge pressure (flush-mounted) |
| Measuring span | Maximum permissible operating pressure |
| <ul style="list-style-type: none"> 8 ... 250 mbar g (0.12 ... 3.6 psi g) 0.01 ... 1 bar g (0.15 ... 14.5 psi g) 0.04 ... 4 bar g (0.58 ... 58 psi g) 0.16 ... 16 bar g (2.3 ... 232 psi g) 0.6 ... 63 bar g (9.1 ... 914 psi g) | <ul style="list-style-type: none"> 2 bar g (29 psi g) 4 bar g (58 psi g) 7 bar g (102 psi g) 21 bar g (305 psi g) 67 bar g (972 psi g) |
| Depending on the process connection, the measuring span may differ from these values | |
| Lower measuring limit | |
| <ul style="list-style-type: none"> Measuring cell with silicone oil | 30 mbar a (0.44 psi a) |
| Upper measuring limit | |
| <ul style="list-style-type: none"> Measuring cell with silicone oil | 100% of maximum measuring span |

| Output | |
|--|---|
| Output signal | 4 ... 20 mA |
| <ul style="list-style-type: none"> Lower limit (infinitely adjustable) Upper limit (infinitely adjustable) Ripple (without HART communication) Electrical damping time constants (T_{63}) Current sensor Failure signal | <ul style="list-style-type: none"> Set to 3.84 mA (min. 3.55 mA) Set to 20.5 mA (max. 23 mA) $I_{ss} \leq 0.5\%$ of maximum output current 0 ... 100 s 3.55 mA ... 23 mA 3.55 mA ... 23 mA |

Specifications

9.2 SITRANS P300 gauge pressure / absolute pressure (flush-mounted)

| Output | |
|----------------------------|--|
| Load | Resistor R [Ω] |
| Without HART communication | $R = \frac{U_H - 10,5 \text{ V}}{23 \text{ mA}}$ |
| | U_H Auxiliary power |
| With HART communication | |
| • HART Communicator | R = 230 ... 500 Ω |
| • SIMATIC PDM | R = 230 ... 1100 Ω |
| Characteristic curve | Linearly rising or linearly falling |

| Measuring accuracy | |
|---|--|
| Reference conditions | <ul style="list-style-type: none"> • Rising characteristic curve • Zero point 0 bar • Seal diaphragm: stainless steel • Measuring cell with silicone oil • Room temperature 25 °C (77 °F) • Measuring span ratio r <p>r = maximum measuring span or set measuring span</p> |
| Measurement deviation with cut-off point setting, including hysteresis and repeatability. | |
| Linear characteristic curve | |
| • r ≤ 10 | ≤ (0.0029 • r + 0.071) % |
| • 10 < r ≤ 30 | ≤ (0.0045 • r + 0.071) % |
| • 30 < r ≤ 100 | ≤ (0.005 • r + 0.05) % |
| Settling time T ₆₃ without electrical damping | Approx. 0.2 s |
| Long-term drift at ±30 °C (±54 °F) | In 5 years |
| | ≤ (0.25 • r) % |
| Influence of ambient temperature | As percentage |
| • at -10 ... +60 °C (14 ... 140 °F) | ≤ (0.1 • r + 0.2) % |
| • at -40 ... -10 °C and +60 ... +85 °C (-40 ... 14 °F and 140 ... 185 °F) | ≤ (0.1 • r + 0.15) % per 10 K ≤ (0.1 • r + 0.15) % per 10 K |
| Influence of process temperature | In pressure per change of temperature |
| • Temperature difference between the process temperature and the ambient temperature | 3 mbar per 10 K (0.04 psi per 10 K) |
| Influence of installation position | In pressure per change of angle |
| | 0.4 mbar (0.006 psi) per 10° |
| | Correction via zero point calibration |
| Influence of auxiliary power | In percent per change of voltage |
| | 0.005% per 1 V |

| Operating conditions | |
|---|---|
| Installation conditions | |
| Ambient temperature | |
| Observe the temperature class in areas subject to explosion hazard. | |
| • Measuring cell with silicone oil | -40 °C ... +85 °C (-40 °F ... 185 °F) |
| • Digital display | -30 °C ... +85 °C (-22 °F ... 185 °F) |
| • Storage temperature | -50 °C ... +85 °C (-58 °F ... 185 °F) |
| Climatic class | |
| • Condensation | permitted |
| Degree of protection | |
| As per EN 60 529 | IP65, IP68, NEMA 4X, enclosure cleaning, resistant to lyes, steam to 150 °C |
| Electromagnetic compatibility | |
| • Spurious emission and resistance to interference | As per EN 61 326 and NAMUR NE 21 |
| Process conditions | |
| Medium temperature | |
| • Measuring cell with silicone oil | -25 °C ... +150 °C (-13 °F ... 302 °F) -25 °C ... +200 °C (-13 °F ... 392 °F) with temperature decoupler |

| Design | |
|----------------------------|---|
| Weight | Approx. 1 ... 13 kg (2.2 ... 29 lb) |
| Material | |
| Wetted parts materials | |
| • Process connection | Stainless steel, mat. no. 1.4404/316L |
| • Seal diaphragm | Stainless steel, mat. no. 1.4404/316L |
| Non-wetted parts materials | |
| • Electronics housing | Electropolished stainless steel, mat. no. 1.4301 |
| Measuring cell filling | |
| | <ul style="list-style-type: none"> • Silicone oil • Neobee M20 • Medical white oil |
| Process connection | |
| | <ul style="list-style-type: none"> • Flanges as per EN and ASME • F&B and pharmaceutical flanges • Bioconnect/Biocontrol • PMC Style |
| Electrical connection | |
| | <ul style="list-style-type: none"> • Cable entry via threaded connection M20x1.5 (plastic) • Cable entry via threaded connection M20x1.5 (metal with screening) |

Specifications

9.2 SITRANS P300 gauge pressure / absolute pressure (flush-mounted)

Auxiliary power U_H

| | |
|---------------------------------|---|
| Terminal voltage at transmitter | <ul style="list-style-type: none">• DC 10.5 V ... 42 V• In the case of intrinsically safe operation DC 10.5 V ... 30 V |
| Ripple | $U_{SS} \leq 0,2 \text{ V}$ (47 ... 125 Hz) |
| Noise | $U_{eff} \leq 1.2 \text{ V}$ (0.5 ... 10 Hz) |

Certificates and approvals

| | |
|--|--|
| Classification according to Pressure Equipment Directive (PED 97/23/EC) | For gases of Fluid Group 1 and liquids of Fluid Group 1; meets requirements of Article 3 Para. 3 (Good engineering practice) |
| Water, waste water | In preparation |
| Explosion protection | |
| Intrinsic safety "i" | PTB 05 ATEX 2048 |
| <ul style="list-style-type: none">• Identification• Permissible ambient temperature | Ex II 1/2 G EEx ia/ib IIB/IIC T4, T5, T6 -40 ... +85 °C (-40 ... +185 °F) temperature class T4 -40 ... +70 °C (-40 ... +158 °F) temperature class T5 -40 ... +60 °C (-40 ... +140 °F) temperature class T6 |
| <ul style="list-style-type: none">• Connection | To certified intrinsically safe circuits with maximum values: $U_i = 30 \text{ V}$, $I_i = 100 \text{ mA}$ $P_i = 750 \text{ mW}$, $R_i = 300 \Omega$ |
| <ul style="list-style-type: none">• Effective inner capacitance:• Effective inner inductance: | $C_i = 6 \text{ nF}$ $L_i = 0.4 \text{ mH}$ |

Communication

| | |
|-----------------------|-----------------------|
| HART communication | 230 ... 1100 Ω |
| Protocol | HART Version 5.x |
| Software for computer | SIMATIC PDM |

See also

PMC Style (Page 10-7)

SITRANS P300 gauge pressure / absolute pressure (flush-mounted) (Page 10-2)

Flanges as per EN and ASME (Page 10-3)

F&B and pharma flange (Page 10-4)

Bioconnect/Biocontrol (Page 10-5)

Dimension drawings

10.1 SITRANS P300 gauge pressure / absolute pressure

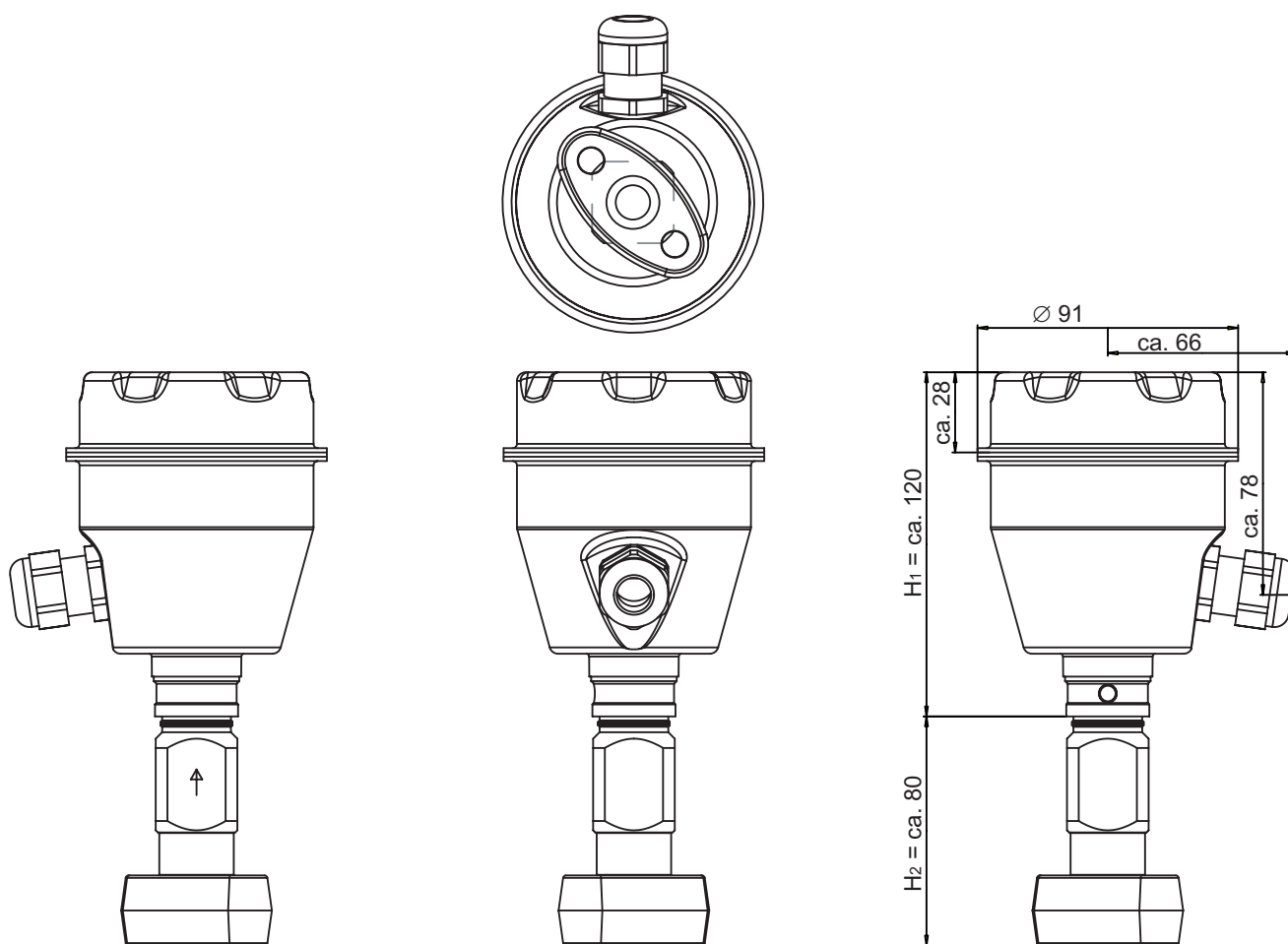

Figure 10-1 SITRANS P300 with oval flange

10.2 SITRANS P300 gauge pressure / absolute pressure (flush-mounted)

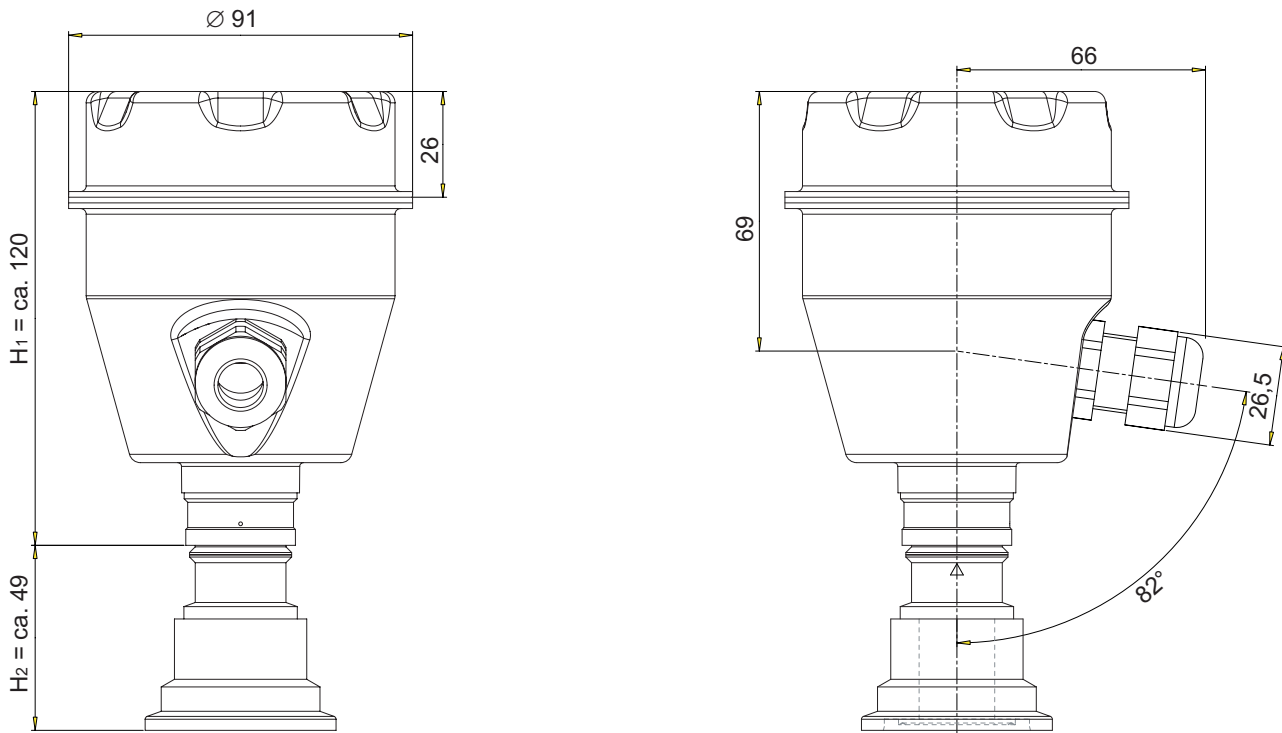

Figure 10-2 SITRANS P300 (flush-mounted)

The diagram shows a SITRANS P300 with an example of a flange. In this drawing the height is subdivided into H_1 and H_2 .

H_1 Height of the SITRANS P300 up to a defined cross-section

H_2 Height of the flange up to this defined cross-section

Height H_2 only is indicated in the dimensions of the flanges.

10.3 Flanges as per EN and ASME

Flange as per EN

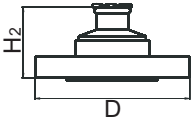
| EN 1092-1 | | | | |
|---|----|-----|---------------|----------------------|
| | DN | PN | ØD | H ₂ |
|  | 25 | 40 | 115 mm (4.5") | Approx. 55 mm (2.2") |
| | 25 | 100 | 140 mm (5.5") | Approx. 55 mm (2.2") |
| | 40 | 40 | 150 mm (5.9") | Approx. 55 mm (2.2") |
| | 40 | 100 | 170 mm (6.7") | Approx. 55 mm (2.2") |
| | 50 | 16 | 165 mm (6.5") | Approx. 55 mm (2.2") |
| | 50 | 40 | 165 mm (6.5") | Approx. 55 mm (2.2") |
| | 80 | 16 | 200 mm (7.9") | Approx. 55 mm (2.2") |
| | 80 | 40 | 200 mm (7.9") | Approx. 55 mm (2.2") |

Flanges as per ASME

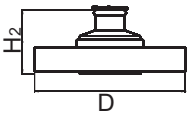
| ASME B 16.5 | | | | |
|---|--------|-------|----------------|----------------------|
| | DN | CLASS | ØD | H ₂ |
|  | 1" | 150 | 110 mm (4.3") | Approx. 53 mm (2.1") |
| | 1" | 300 | 125 mm (4.9") | Approx. 53 mm (2.1") |
| | 1 1/2" | 150 | 130 mm (5.1") | Approx. 53 mm (2.1") |
| | 1 1/2" | 300 | 155 mm (6.1") | Approx. 53 mm (2.1") |
| | 2" | 150 | 150 mm (5.9") | Approx. 53 mm (2.1") |
| | 2" | 300 | 165 mm (6.5") | Approx. 53 mm (2.1") |
| | 3" | 150 | 190 mm (7.5") | Approx. 53 mm (2.1") |
| | 3" | 300 | 210 mm (8.1") | Approx. 54 mm (2.1") |
| | 4" | 150 | 230 mm (9.1") | Approx. 53 mm (2.1") |
| | 4" | 300 | 255 mm (10.0") | Approx. 57 mm (2.2") |

10.4 F&B and pharma flange

Connections as per DIN

DIN 11851

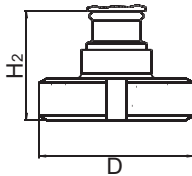

| DN | PN | ∅D | H ₂ |
|----|----|--------------|----------------------|
| 25 | 40 | 63 mm (2.5") | Approx. 55 mm (2.2") |
| 32 | 40 | 70 mm (2.8") | Approx. 55 mm (2.2") |
| 40 | 40 | 78 mm (3.1") | Approx. 55 mm (2.2") |
| 50 | 40 | 92 mm (3.6") | Approx. 55 mm (2.2") |
| 80 | 40 | 127 mm (5") | Approx. 55 mm (2.2") |

DIN 11864-1

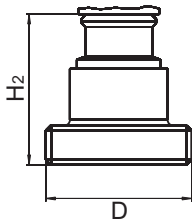

| DN | PN | ∅D | H ₂ |
|-----|----|-----------------|----------------------|
| 25 | 40 | 52.4 mm (2.1") | Approx. 54 mm (2.1") |
| 40 | 40 | 65.4 mm (2.6") | Approx. 54 mm (2.1") |
| 50 | 40 | 78.4 mm (3.1") | Approx. 54 mm (2.1") |
| 100 | 40 | 130.6 mm (5.1") | Approx. 54 mm (2.1") |

DIN 11864-2

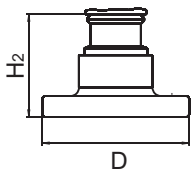

| DN | PN | ∅D | H ₂ |
|-----|----|---------------|----------------------|
| 25 | 40 | 70 mm (2.8") | Approx. 49 mm (1.9") |
| 40 | 40 | 82 mm (3.2") | Approx. 49 mm (1.9") |
| 50 | 40 | 94 mm (3.7") | Approx. 49 mm (1.9") |
| 100 | 40 | 159 mm (6.3") | Approx. 49 mm (1.9") |

DIN 11864-3

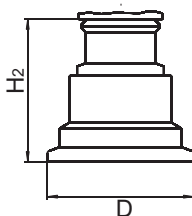

| DN | PN | ∅D | H ₂ |
|-----|----|----------------|----------------------|
| 25 | 40 | 50,5 mm (2") | Approx. 49 mm (1.9") |
| 40 | 40 | 64 mm (2.5") | Approx. 49 mm (1.9") |
| 50 | 40 | 77,5 mm (3.1") | Approx. 49 mm (1.9") |
| 100 | 40 | 130 mm (5.1") | Approx. 49 mm (1.9") |

Tri-Clamp as per DIN 32676

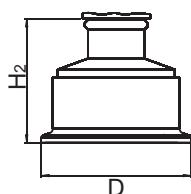

| DN | PN | ØD | H ₂ |
|-----|----|---------------|----------------------|
| 20 | 40 | 34 mm (1.3") | Approx. 53 mm (2.1") |
| 25 | 40 | 50.5 mm (2") | Approx. 53 mm (2.1") |
| 32 | 40 | 50.5 mm (2") | Approx. 53 mm (2.1") |
| 40 | 40 | 50.5 mm (2") | Approx. 53 mm (2.1") |
| 50 | 40 | 64 mm (2.5") | Approx. 53 mm (2.1") |
| 65 | 40 | 91 mm (3.6") | Approx. 53 mm (2.1") |
| 80 | 40 | 106 mm (4.2") | Approx. 53 mm (2.1") |
| 100 | 40 | 119 mm (4.7") | Approx. 53 mm (2.1") |

Other connections

Varivent® connector

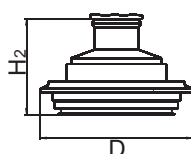

| DN | PN | ØD | H ₂ |
|--------|----|--------------|----------------------|
| 25-32 | 40 | 66 mm (2.6") | Approx. 53 mm (2.1") |
| 40-125 | 40 | 84 mm (3.3") | Approx. 53 mm (2.1") |

10.5 Bioconnect/Biocontrol

Bioconnect™ connector

Bioconnect™ screw connector

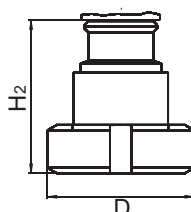

| DN | PN | ØD | H ₂ |
|-----|----|---------------|----------------------|
| 25 | 40 | 55 mm (2.2") | Approx. 57 mm (2.2") |
| 50 | 40 | 82 mm (3.2") | Approx. 57 mm (2.2") |
| 100 | 40 | 145 mm (5.7") | Approx. 57 mm (2.2") |

Bioconnect™ flange connector

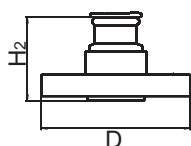

| DN | PN | ØD | H ₂ |
|-----|----|---------------|----------------------|
| 25 | 40 | 85 mm (3.3") | Approx. 48 mm (1.9") |
| 50 | 40 | 110 mm (4.3") | Approx. 48 mm (1.9") |
| 100 | 40 | 175 mm (6.9") | Approx. 48 mm (1.9") |

Bioconnect™ clamp connector

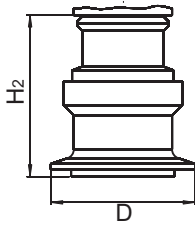

| DN | PN | ∅D | H ₂ |
|-----|----|---------------|----------------------|
| 25 | 40 | 50,5 mm (2") | Approx. 48 mm (1.9") |
| 40 | 40 | 50,5 mm (2") | Approx. 48 mm (1.9") |
| 50 | 40 | 64 mm (2.5") | Approx. 48 mm (1.9") |
| 65 | 40 | 91 mm (3.6") | Approx. 48 mm (1.9") |
| 80 | 40 | 106 mm (4.2") | Approx. 48 mm (1.9") |
| 100 | 40 | 119 mm (4.7") | Approx. 48 mm (1.9") |

Other connections

Biocontrol™ connector

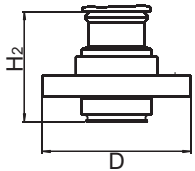

| DN | PN | ∅D | H ₂ |
|-----|----|---------------|----------------------|
| 25 | 40 | 64 mm (2.5") | Approx. 48 mm (1.9") |
| 50 | 40 | 90 mm (3.5") | Approx. 48 mm (1.9") |
| 100 | 40 | 120 mm (4.7") | Approx. 48 mm (1.9") |

Connect S™ flanged joint

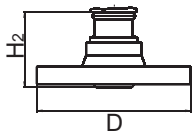

| DN | PN | ∅D | H ₂ |
|-----|----|---------------|----------------------|
| 25 | 40 | 85 mm (3.3") | Approx. 47 mm (1.9") |
| 32 | 40 | 95 mm (3.7") | Approx. 47 mm (1.9") |
| 40 | 40 | 100 mm (3.9") | Approx. 47 mm (1.9") |
| 50 | 40 | 110 mm (4.3") | Approx. 47 mm (1.9") |
| 65 | 40 | 140 mm (5.5") | Approx. 47 mm (1.9") |
| 80 | 40 | 150 mm (5.9") | Approx. 47 mm (1.9") |
| 100 | 40 | 175 mm (6.9") | Approx. 47 mm (1.9") |

10.6 PMC Style

Connections for the paper industry

PMC Style Standard

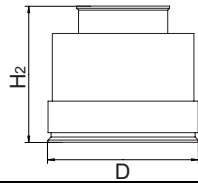

| DN | PN | ØD | H ₂ |
|------------------|----|----------------|------------------------|
| - | - | 40.4 mm (1.6") | Approx. 36.8 mm (1.4") |
| M44x1.25 cap nut | | | |

PMC-Style Minibolt

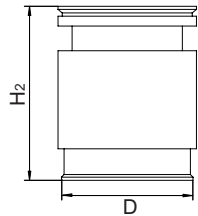

| DN | PN | ØD | H ₂ |
|----|----|--------------|------------------------|
| - | - | 26.3 mm (1") | Approx. 33.1 mm (1.3") |

A

Appendix

A.1 Overview of HART operating structure

The following overview applies to the HART communicator operating structure..

Appendix

A.1 Overview of HART operating structure

| | | | | | |
|-------------------|-----------------------|-----------------------------|--|-------------------------|--|
| 2 Online | 1 (PV meas) *) | | | | |
| | 2 (PV) status | | | | |
| | 3 Module type | | | | |
| | 4 Identification | 1 Operation Unit | 1 Tag | | |
| | | | 2 Long Tag --> M **) | | |
| | | | 3 Descriptor | | |
| | | | 4 Message | | |
| | | | 5 Date | | |
| | | 2 Device | 1 Manufacturer | | |
| | | | 2 Model | | |
| | | | 3 Device identification | | |
| | | | 4 Distributor | | |
| | | | 5 MLFB Order Number | 1 MLFB Order No --> M | |
| | | | 6 Measurement type | | |
| | | | 7 Fabrication-No | | |
| | | | 8 Final assembly number | | |
| | | | 9 Sensor serial number | | |
| | | | 10 Revisions | 1 Universal rev. | |
| | | | | 2 Field device rev. | |
| | | | | 3 Software rev. | |
| | | | | 4 Hardware rev. | |
| | | 3 Basic Parameters | 1 Pressure unit | | |
| | | | 2 LSL (Lower Sensor Limit) | | |
| | | | 3 USL (Upper Sensor Limit) | | |
| | | 4 Minimum Span | | | |
| | | 5 LRV (Lower Range Value) | | | |
| | | 6 URV (Upper Range Value)) | | | |
| | | 7 Pressure damping | | | |
| | | 8 Pressure xfer function | xfer = transfer | | |
| 5 Config Inp/Outp | 1 Quick-Setup & Meas. | 1 PV, Current, Status | 1 (PV meas) *) | | |
| | | | 2 AO (analogue output) | | |
| | | | 3 (PV) % range | | |
| | | | 4 Status see --> | 6 Diagnosis/Service | |
| | | | 5 Measurement type | | |
| | | 2 Meas.Val. & Status | 1 Pressure Values | 1 Pressure | |
| | | | | 2 Pres status | |
| | | | | 3 Untrimmed pressure | |
| | | | | 4 Untrimmed pres status | |
| | | | 2 Temperature Values | 1 Sens-Temp | |
| | | | | 2 Sens-Temp status | |
| | | | | 3 Electr-Temp | |
| | | | | 4 Electr-Temp status | |
| | | | 3 Level, Vol, Mass Values (shown if valid items) | 1 Level | |
| | | | | 2 Level status | |
| | | | | 3 Volume | |
| | | | | 4 Volume status | |
| | | | | 5 Mass | |
| | | | | 6 Mass status | |
| | | | 4 Vol-, Mass- & Flow (shown if valid items) | 1 Vol-Flow | |
| | | | | 2 Vol-Flow status | |
| | | | | 3 Mass-Flow | |
| | | | | 4 Mass-Flow status | |
| | | | 5 Appl & Stat (shown if valid items) | 1 Customer | |
| | | | | 2 Customer Status | |
| | | 3 Quick-Setup | 1 Tag | | |
| | | | 2 Ext TAG --> M | | |
| | | | 3 PV is | | |
| | | | 4 (PV) unit | | |
| | | | 5 Position correction | 1 Position corr --> M | |
| | | | 6 LRV | | |
| | | | 7 URV | | |
| | | | 8 Pressure damping | | |
| | | | 9 Pressure xfer function | | |
| | 2 Input | 1 Config Pres/Temp | 1 Pressure sensor | 1 Pressure | |
| | | | | 2 Untrimmed pres | |
| | | | | 3 Pressure units | |
| | | | | 1 Pres abs/rel | |
| | | | | 2 Pressure unit | |
| | | | | 3 Untrimmed pres unit | |
| | | | 2 Temperature sensor | 1 Sens-Temp | |
| | | | | 2 Electr-Temp | |
| | | | | 3 Temp units | |
| | | | | 1 Sens-Temp unit | |
| | | | | 2 Electr-Temp unit | |
| | | | 3 Pres units see --> | 1 Pressure sensor | |
| | | | 4 Temp units see --> | 1 Temperature sensor | |
| | | 2 Display Process Variables | 1 Prozess variables | 1 (PV measurement) | |
| | | | | 2 (PV) %mge | |
| | | | | 3 AO | |
| | | | | 4 (SV measurement) | |
| | | | | 5 (TV measurement) | |
| | | | | 6 (QV measurement) | |
| | | 3 Meas Switch/Mapper | 1 measurement | | |
| | | | 2 PV is | | |
| | | | 3 SV is | | |
| | | | 4 TV is | | |
| | | | 5 QV is | | |
| | | | 6 (measurement) config e.g. Level | 1 Input scaling | |
| | | | | 1 Pres abs/rel | |
| | | | | 2 Pressure unit | |
| | | | | 3 Input LRV | |
| | | | | 4 Input URV | |
| | | | 2 Level scaling e.g. Level scaling | 1 Level unit | |
| | | | | 2 Level LRV | |
| | | | | 3 Level URV | |

A.1 Overview of HART operating structure

| | | | | |
|--|----------------------|--|--|---|
| | | | 3 Volume scaling | 1 Volume unit 2 Vol LRV 3 Vol URV 2 Density unit 3 Density 3 Mass unit |
| | | 6 (measurement) config e.g. Flow | 1 Input scaling 2 Flow scaling | 1 Pres abs/rel 2 Pressure unit 3 Input LRV 4 Input URV 1 Vol flow unit 2 Vol flow LRV 3 Vol flow URV 2 Density unit 3 Density 3 Mass flow unit |
| | | 6 (measurement) config e.g. Customer | 1 Input scaling 3 Customer scaling | 1 Pres abs/rel 2 Pressure unit 3 Input LRV 4 Input URV 1 Cust unit (5 Ch) 2 Cust LRV 3 Cust URV |
| | | 7 Unser linearization if Level, Flow or Customer this is valid - otherwise not | 1 Special Curve status --> 2 No curve points 3 Setup special char --> M 4 Display special char --> M | only if meas not pres |
| | 4 Meas.Limits & Span | 1 Module range 2 Active Device Variables | 1 Pressure 2 Sens-Temp 3 Electr-Temp 4 Untrimmed Pres 5 Level 6 Volume 7 Mass 5 Vol-Flow 6 Mass-Flow 5 Customer | 1 Pressure unit 2 Pres USL 3 Pres LSL 4 Trimpoint sum 5 Pres min.span 1 Sens-Temp unit 2 Sens-Temp USL 3 Sens-Temp LSL 4 Sens-Temp min.span 1 Electr-Temp unit 2 Electr-Temp USL 3 Electr-Temp LSL 4 Electr-Temp min.span 1 Untrimmed Pres unit 2 Untrimmed Pres USL 3 Untrimmed Pres LSL 4 Untr Pres min.span 1 Level unit 2 Level USL 3 Level LSL 4 Level min.span 1 Volume unit 2 Volume USL 3 Volume LSL 4 Volume min.span 1 Mass unit 2 Mass USL 3 Mass LSL 4 Mass min.span 1 Vol-Flow unit 2 Vol-Flow USL 3 Vol-Flow LSL 4 Vol-Flow min.span 1 Mass-Flow unit 2 Mass-Flow USL 3 Mass-Flow LSL 4 Mass-Flow min.span 1 (PV) unit 2 Customer USL 3 Customer LSL 4 Customer min. span |
| | 3 Output | 1 Analog output | 1 Analog output 2 Percent range 3 Zero and Span 4 Pres xfer function 5 Startpoint square root 6 Current Limits 7 Alarms | 1 Zero/Span set 2 Out Scaling PV 1 Apply values >1 2 Out Scaling PV >2 >1 Out Scaling PV 1 Unit 2 LRV 3 URV 4 LSL 5 USL >2 Apply values 1 Apply values --> M 1 Lower AO Limit 2 Upper AO Limit 1 AO Alarm Type 2 Alarm LRV 3 Alarm URV |
| | | 2 Sensor trim points | 1 Lower sensor trim point 2 Upper sensor trim point | |
| | | 3 HART output | 1 Polling address 2 Num request preambles 3 Num response preambles | |
| | 4 Local meter | 1 Meter type 2 Unit tracking 3 Local Display unit | | |

Appendix

A.1 Overview of HART operating structure

| | | | | |
|--|--|----------------------------|---------------------------|---------------------------|
| | | 4 LCD Settings | 1 LCD Scaling, if On: | 2 LCD Unit |
| | | 5 Bargraph | | 3 LCD LRV |
| | | 6 Access Control | 1 Lokal keys control mode | 4 LCD URV |
| | | | 2 Write protect | |
| | | | 3 Set write protect --> M | |
| | 5 Mech. Construction Mech = mechanical | 1 No of electronic changes | | |
| | | 2 Design | 1 Sensor | 1 Fill fluid |
| | | | | 2 Isolation material |
| | | | | 3 O ring material |
| | | | | 4 Module range |
| | | | 2 Remote Seal | 1 Number remote seal (RS) |
| | | | | 2 RS type |
| | | | | 3 RS isolator material |
| | | | | 4 RS fill fluid |
| | | | | 5 Extension length |
| | | | | 6 Extension type |
| | | | | 7 Capillar length |
| | | 3 Process Connection | 1 Process Connection | |
| | | | 2 Drain/Vent / plug mat | |
| | | | 3 Drain/Vent / plug pos | |
| | | | 4 Process flange bolt | |
| | | | 5 Flange type | |
| | | | 6 Flange material | |
| | | 4 Electronic Connection | 1 Electr housing material | |
| | | | 2 Electr connection | |
| | 7 Diagnosis/Service | 1 Status | 1 Status summary | |
| | | | 2 Extended device status | |
| | | | 3 Simulation status | |
| | | | 4 Hardw/Firmw status | 1 Status group 2 |
| | | | | 2 Status group 3 |
| | | | | 3 Status group 4 |
| | | | | 4 Status group 5 |
| | | | 5 Diag Alarm Status | 1 Status group 15 |
| | | | | 2 Status group 16 |
| | | | 6 Diag Warn Status | 1 Status group 19 |
| | | | | 2 Status group 20 |
| | | 2 Device | 1 Selftest/Reset | 1 Selftest --> M |
| | | | | 2 Display Test --> M |
| | | | | 3 Master reset --> M |
| | | | | 4 Changes Config |
| | | | | 1 Config changed counter |
| | | | 2 Sensor trim | 1 Restore mfr trims --> M |
| | | | | mfr = manufacturer |
| | | | | 1 Sensor trim points |
| | | | | 1 Lower sensor trim point |
| | | | | 2 Upper sensor trim point |
| | | | | 1 Pres zero trim--> M |
| | | | | 2 Lower sensor trim --> M |
| | | | | 3 Upper sensor trim --> M |
| | | | | 3 Trimpoint summary |
| | | | | 1 D/A trim --> M |
| | | | | 2 Scaled D/A trim --> M |
| | | | 3 Trim analog output | 1 Position corr --> M |
| | | | 4 Position correction | 1 Position corr --> M |
| | | 3 Simulation/Test | 1 Loop test --> M | Simulation AO |
| | | | 2 Inputs --> M | Simulation Fixed / Ramp |
| | | 4 Access Control | 1 Local keys control mode | |
| | | | 2 Write protect | |
| | | | 3 Set write protect --> M | |
| | | 3 Diagnostic settings | 1 W/A time unit | W/A = warning/alarm |
| | | | 2 Calib interval | 1 Calib status |
| | | | | 2 W/A acknowledge --> M |
| | | | | 3 Calib timer |
| | | | | 1 Calib time |
| | | | | 2 Reset timer --> M |
| | | | | 4 Calib warning |
| | | | | 5 Calib alarm |
| | | | | 6 W/A activation |
| | | | 3 Service interval | 1 Service status |
| | | | | 2 W/A acknowledge --> M |
| | | | | 3 Service timer |
| | | | | 1 Service time |
| | | | | 2 Reset timer --> M |
| | | | | 4 Service warning |
| | | | | 5 Service alarm |
| | | | | 6 W/A activation |
| | | | 4 AO saturation | 1 AO alarm type |
| | | | | 2 Saturation alarm |
| | | | | 3 Alarm duration |
| | | | | 4 Alarm activation |
| | | | 5 Limiter setup | 1 Display limiter --> M |
| | | | | 2 Setup limiter --> M |
| | | | | 3 Limiter status --> M |
| | | | | 4 Limiter: Ack W/A --> M |
| | | | | 5 CmpCnt: Ack W/A --> M |
| | | | | 6 Reset counter. --> M |
| | | 4 View | 1 Operating hours | 1 Operating hours Electr |
| | | | | 2 Operating hours Sensor |
| | | | 3 Min/Max pointer | 1 Pressure pointer |
| | | | | 1 Pres max |
| | | | | 2 Pres min |
| | | | | 3 Reset pointer --> M |
| | | | | 1 Electr-Temp pointer |
| | | | | 2 Electr-Temp max |
| | | | | 2 Electr-Temp min |
| | | | | 3 Reset pointer --> M |
| | | | | 1 Sens-Temp pointer |
| | | | | 1 Sens-Temp max |
| | | | | 2 Sens-Temp min |
| | | | | 3 Reset pointer --> M |
| | 6 Certif & Approv Certif=Certification Approv=Approval | 1 Explos. Protection | Explos = Explosion | |

A.2 Certifications

The certifications are enclosed as a loose collection of operating instructions or on CD.

A.3 Pressure equipment directive

The monitoring of the design, dimensioning, testing and manufacture to ensure it is in accordance with Module H (comprehensive quality assurance) by TÜV North as the appointed body.

A.3 Pressure equipment directive

General

The pressure equipment directive **97/23/EC** applies to the alignment of the statutory orders of the European member states for pressure equipment. Such equipment in the sense of the directive includes vessels, pipelines and accessories with a maximum permissible pressure of more than **0.5 bar** above atmospheric.

The pressure equipment directive can be used starting November 29, 1999, and is compulsory starting May 29, 2002.

Division according to the danger potential

Equipment is divided in line with the pressure equipment directive according to the danger potential (medium/pressure/volume/nominal diameter) into the categories I to IV or Article 3 Paragraph 3.

The following criteria are decisive for assessment of the danger potential, and are also shown in Diagrams 1 to 4 and 6 to 9:

| | |
|---------------------------------|--|
| • Fluid group | Group 1 or 2 |
| • Aggregate state | Liquid or gaseous |
| • Type of pressurized equipment | |
| - Vessel | Product of pressure and volume (PS * V [barL]) |
| - Pipeline | Nominal diameter, pressure or product of pressure and nominal diameter (PS * DN) |

Fuelled pressure equipment or equipment heated in another manner are shown separately in Diagram 5.



Note:

Liquids according to Article 3 are those liquids whose steam pressure is **not** more than **0.5 bar** above standard atmospheric pressure (1013 mbar) at the maximum permissible temperature.

The **maximum permissible temperature** for the used liquids is the maximum process temperature which can occur, as defined by the user. This must be within the limits defined for the equipment.

Division of media (liquid/gaseous) into the fluid groups

Fluids are divided according to Article 9 into the following fluid groups:

| Group 1 | Potentially explosive | Highly toxic |
|---|--|--|
|  | R phrases: e.g.: 2, 3 (1, 4, 5, 6, 9, 16, 18, 19, 44) | R phrases: e.g.: 26, 27, 28, 39 (32) |
|  | Highly flammable R phrases: e.g.: 12 (17) | Toxic R phrases: e.g.: 23, 24, 25 (29, 31) |
|  | Readily flammable R phrases: e.g.: 11, 15, 17 (10, 30) | Fire stimulating R phrases: e.g.: 7, 8, 9 (14, 15, 19) |

Flammable if the maximum permissible temperature is above the flash point.

| Group 2 |
|---|
| All fluids not belonging to Group 1. Also applies to fluids which are e.g. dangerous to the environment, corrosive, dangerous to health, irritant or carcinogenic (if not highly toxic). |

Conformity rating

Pressure equipment of categories I to IV must comply with the safety requirements of the directive and be assigned the CE symbol.

They must comply with a conformity rating procedure according to Appendix III of the directive.

Pressure equipment according to Article 3 Paragraph 3 must be designed and manufactured in agreement with the sound engineering practice SEP applying in a member country, and must not be assigned a CE symbol (CE symbols from other directives are not affected).

Siemens has carried out a conformity rating, assigned a CE symbol, and issued a declaration of conformity for its products (providing the equipment is not within the context of Article 3 Paragraph 3).

Supervision of the design, dimensioning, testing and manufacture is carried out according to module H (comprehensive quality assurance) by the TÜV Nord (Northern Technical Inspectorate) as the specified office.

Notes:

- Equipment designed for media with a high danger potential (e.g. gases of fluid group 1) may also be used for media with a lower danger potential (e.g. gases of fluid group 2, or liquids of fluid groups 1 and 2).
- The pressure equipment directive according to Article 1 Paragraph 1 does not apply to equipment such as e.g. mobile offshore plants, ships, aircraft, water supply and waste water networks, nuclear plants, rockets and pipelines outside industrial plants.



Figure A-1 Pressure equipment directive, sheet 1

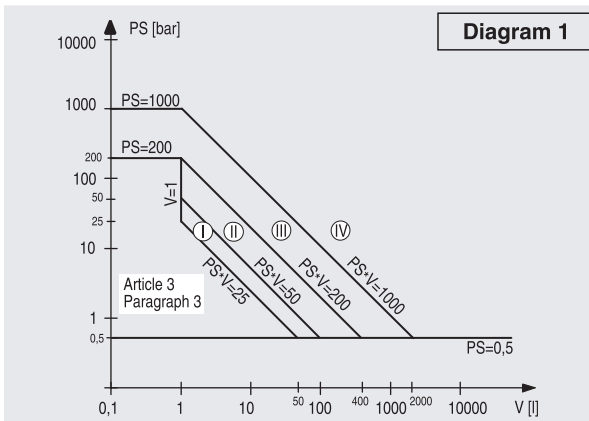

- Gases of fluid group 1
- Vessels according to Article 3 Number 1.1 Letter a) First dash
- Exception: unstable gases belonging to Categories I and II must be included in Category III.

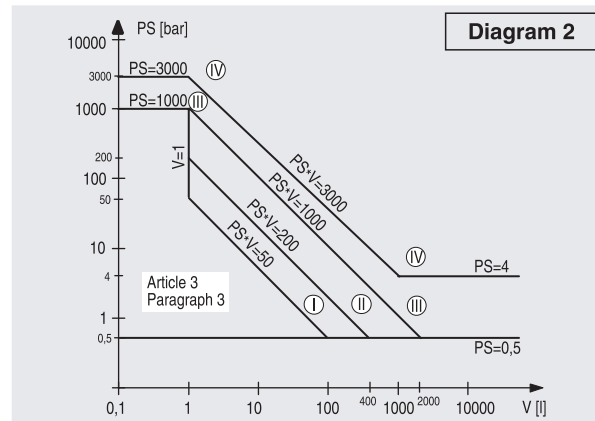

- Gases of fluid group 2
- Vessels according to Article 3 Number 1.1 Letter a) Second dash
- Exception: fire extinguishers and bottles for breathing apparatus: at least Category III.

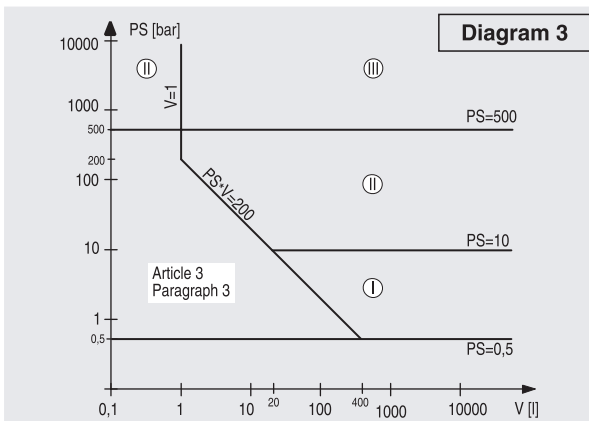

- Liquids of fluid group 1
- Vessels according to Article 3 Number 1.1 Letter b) First dash

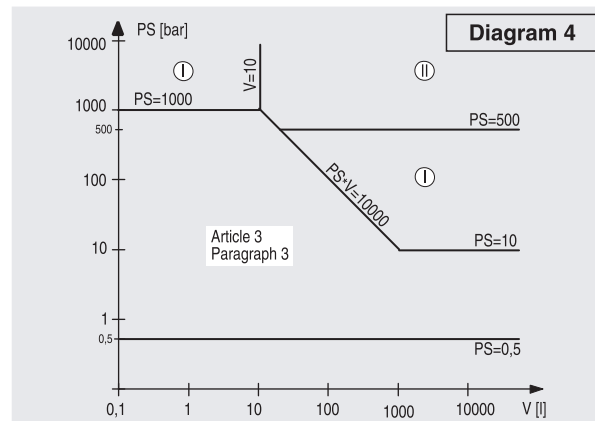

- Liquids of fluid group 2
- Vessels according to Article 3 Number 1.1 Letter b) Second dash
- Exception: modules for producing warm water

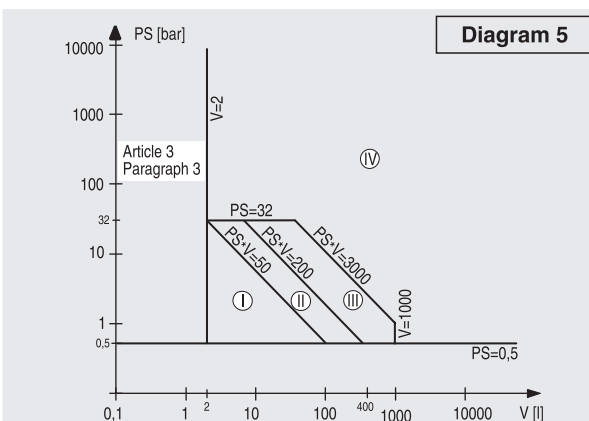

- Fuelled pressure equipment or equipment heated in another manner above 110 °C and liable to overheating.
- Vessel according to Article 3 Number 1.2
- Exception: pressure cooker, test procedure at least according to Category III.

Figure A-2 Pressure equipment directive, sheet 2

A.3 Pressure equipment directive

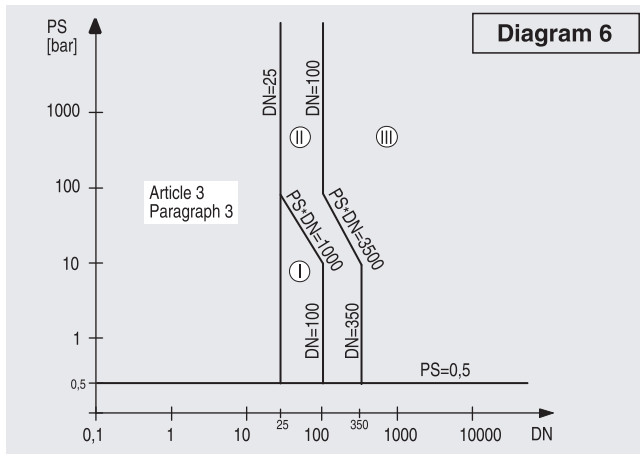

- Gases of fluid group 1
- Pipelines according to Article 3 Number 1.3 Letter a) First dash
- Exception: unstable gases belonging to Categories I and II must be included in Category III.

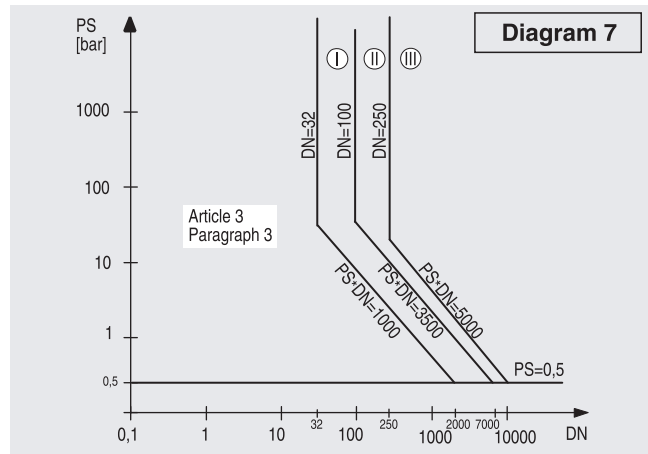

- Gases of fluid group 2
- Pipelines according to Article 3 Number 1.3 Letter a) Second dash
- Exception: liquids at temperatures > 350 °C belonging to Category II must be included in Category III.

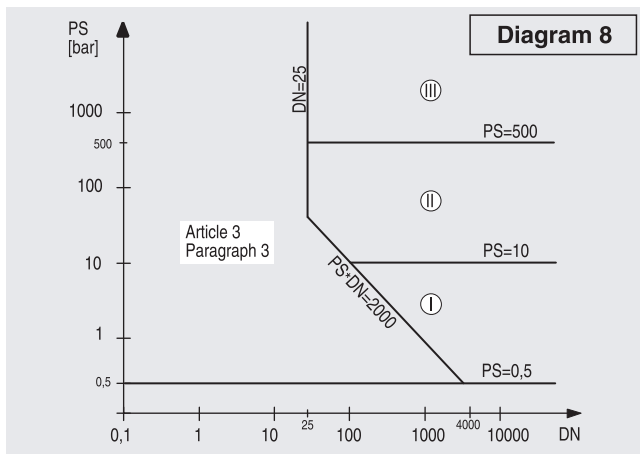

- Liquids of fluid group 1
- Pipelines according to Article 3 Number 1.3 Letter b) First dash

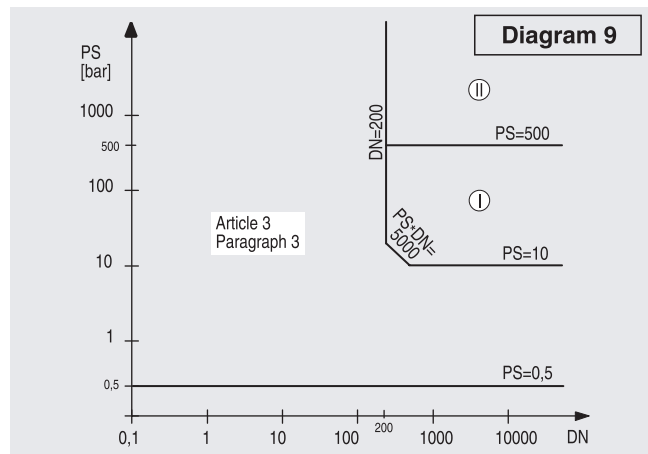

- Liquids of fluid group 2
- Pipelines according to Article 3 Number 1.3 Letter b) Second dash

Figure A-3 Pressure equipment directive, sheet 3

List of Abbreviations/Acronyms

B.1 Pressure transmitter abbreviations

List of abbreviations

Table B-1 Variables

| Abbreviation | In full | Meaning |
|--------------|----------------------|---------|
| PV | Primary variable | |
| SV | Secondary variable | |
| TV | Tertiary variable | |
| QV | Quarternary variable | |

Table B-2 Units

| Abbreviation | In full | Meaning |
|--------------|--------------|--|
| bar a | bar absolute | Unit of pressure for absolute pressure |
| bar g | bar gauge | Unit of pressure for gauge pressure |
| lb | Pound | Unit of weight |
| psi a | psi absolute | Unit of pressure for absolute pressure |
| psi g | psi gauge | Unit of pressure for gauge pressure |

Table B-3 Other abbreviations

| Abbreviation | In full | Meaning |
|--------------|---------------------------------------|--|
| PED | Pressure equipment directive | |
| HART | Highway Addressable Remote Transducer | Standard protocol for the transmission of information between field device and automation system |
| MA | Zero point | |
| ME | Limit point | |
| F&B | Food and beverage industry | |
| PDM | Process Device Manager | |

Index

A

Ambient temperature, 9-3, 9-7
Arrow display, 6-7
Auxiliary power, 9-4

C

Certificate, A-4
Certification, A-4
Constant current operation, 6-26
Current limit, 7-18
Current sensor, 6-26

D

Degree of protection, 3-5
Device variable, 6-7
Digital display, 3-4

E

Electromagnetic compatibility, 9-3, 9-7
EMC, 9-3, 9-7

F

Firmware, 3-5
Flange, 4-6

H

HART
Modem, 3-1

L

LCD, 3-4
LCD scaling, 7-14
Load, 9-6
With HART communication, 9-2

Without HART communication, 9-2

M

Mapper, 7-4
Measured value display, 6-30
Measurement, 7-2
Measurement type selector, 7-2
Message
OVER, 6-8
UNDER, 6-8

N

Nameplate, 3-5

O

Operating structure, A-1
Order no., 3-5

P

PED, A-5
Position correction, 6-25
Pressure equipment directive
Conformity evaluation, A-5
Diagrams, A-7, A-8
Hazard potential, A-5
Primary variable, 6-7

S

Saturation limit, 7-18
Serial number, 3-5
Signal range, 6-7

T

Test connector, 6-9

Z

Zero point calibration, 6-25