

# High pressure rig IVA 500



	Seite
Please read prior to initialization!	2
Purpose of the pressure rig	3
Mounting of the device	3
Mounting of the sensor	3
Alignment of the sensor	3
Removal of the sensor	3
Assignment of the items	4
List of items	5
Alignment of the sensor	5
Ordering data	6



---

**Please read before initialization!**

---

Attention: **Recommended for measurement from 10 bar to 50 bar .**

Please observe measuring ranges of the sensor!

The sensor has to be screwed-in pressure-tightly.

The manufacturer cannot be held liable for any damage which occurs as a result of non-observance or non-compliance with these instructions. Should the device be tampered with in any matter other than a procedure which is described and specified in the manual, the warranty is cancelled and the manufacturer is exempt from liability.

The device is destined exclusively for the described application.

ICS Schneider Messtechnik GmbH offers no guarantee for the suitability for any other purpose and is not liable for errors which may have slipped into this operation manual. ICS Schneider Messtechnik GmbH is also not liable for consequential damage resulting from the delivery, capability or use of this device.

---

## PURPOSE OF THE PRESSURE RIG

---

The supplementary device "high pressure rig " serves for a safe installation and fastening of the sensors IVA 300 and IVA 400 under pressure. It is strongly recommended to be used for gas or air pressures from 10 bar. It is important and absolutely necessary to read the instruction manuals of the sensors IVA 300 and IVA 400 prior to the installation.

---

## MOUNTING OF THE DEVICE

---

- Set up measuring site with screw neck (G1/2" **outer diameter**) according to the mounting instruction of the sensor IVA 500.
- Screw on the high pressure rig pressure-tightly and make sure that the ball valve can be opened and closed.
- Close ball valve before mounting the sensor.

---

## MOUNTING OF THE SENSOR

---

- Insert the upper plate (3) which has not been fixed yet with its notch into the slot below the sensor head.
- Connect the flexible mounting thread of the sensor IVA 500 gas-tightly to the ball valve.  
**Attention:** Sensor tip is not allowed to touch the ball of the ball valve.
- Adjust the wing nuts (6) that way that the upper plate is secured upwards .
- Adjust the counter nuts (A) as stop position of the upper place for the operating position of the sensor (typically in the middle of the pipe).

---

## INSTALLATION OF THE SENSOR

---

- After opening the ball valve please insert the sensor into the pipeline by permanently screwing of the wing nuts.
- Upon reaching of the operation position of the upper plate please fix the device with the wing nuts and the counter nuts.
- Tighten the adapter sleeve of the sensor screwing according to the mounting instruction of IVA 500.

---

## REMOVAL OF THE SENSOR

---

- Slightly release the adapter sleeve of the sensor screwing.
- Release constantly the wing nuts of the high pressure rig. If there is a sufficient operating pressure the sensor will be pressed back by the medium through the ball valve as far as it will go into the sensor screwing.
- Close ball valve carefully.
- Before removal of the sensor from the device please screw the wing nuts at least by the thread length of the sensor screwing.
- For safety reasons please close the outlet of the ball valve with a G1/2" stopper.

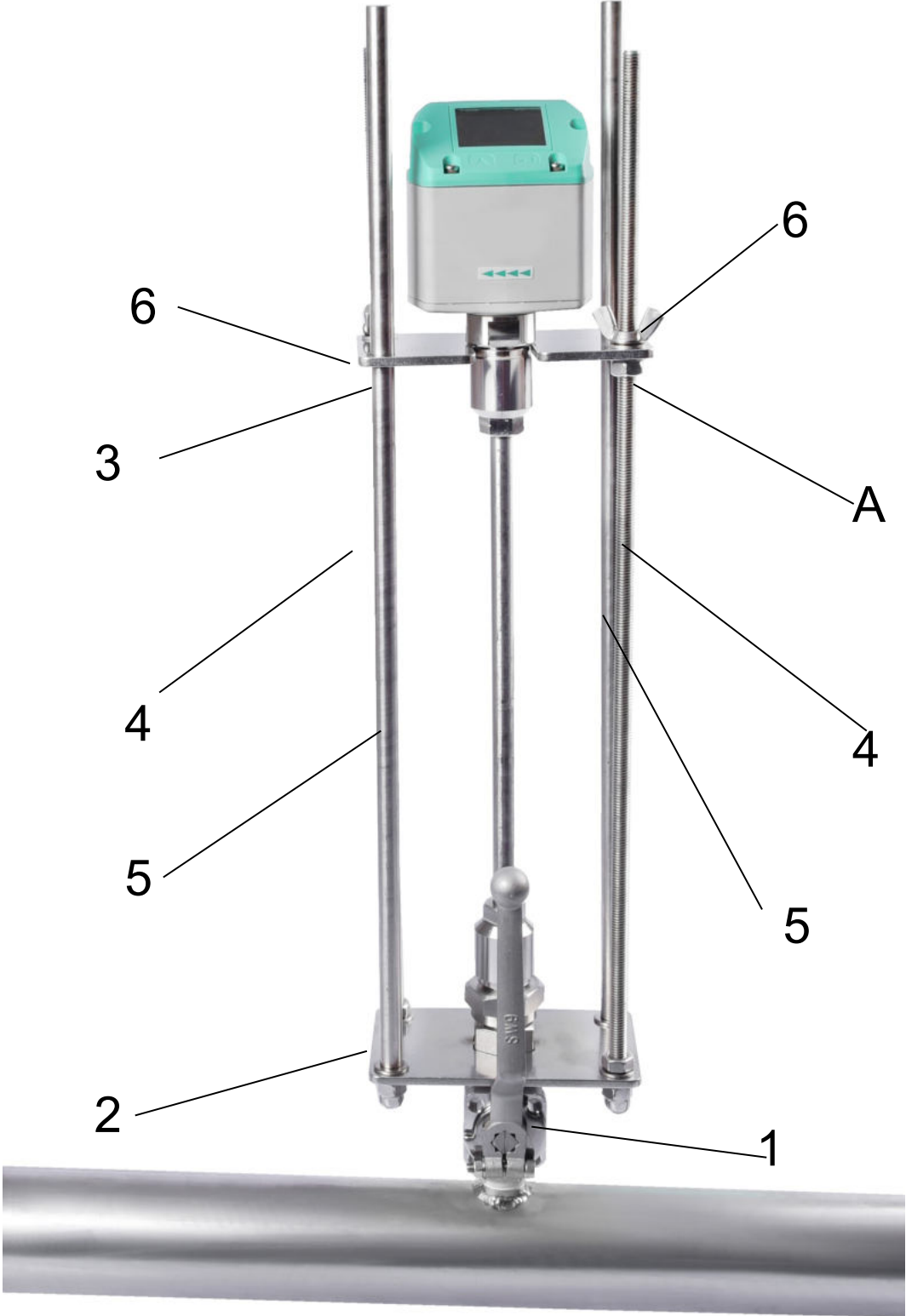

Position	Quantity	Designation of the itme
1	1	Ball valve G1/2", threepart, made of stainless-steel
2	1	Fastening plate
3	1	Upper plate
4	2	Thread bars
5	2	Guide bars
6	2	Wing nuts
		Fastening nuts and washers A = Counter nuts

**ALIGNMENT OF THE SENSOR**

**Safety information must be observed.**

Assembly is carried out by inserting the connection thread (1/2" thread, SW 27) into the connection piece of the ball valve.

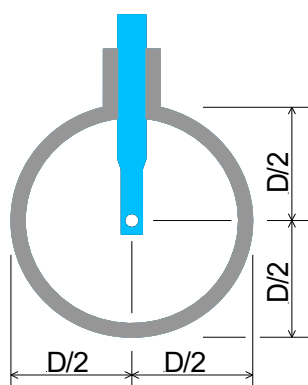

The sensor is then inserted to the required immersion depth and aligned according to the direction of air flow as described on page 3. A depth scale engraved on the probe tube, a flow alignment arrow and an aligning device will be of help to you.

Once the sensor has been aligned, the adapter sleeve must be tightened with the stipulated torque (20 - 30 Nm - SW 17).

Attention: Alignment of the sensor must not be modified when tightening the connection thread and adapter sleeve. In this case please check the immersion depth and alignment again and correct if necessary. The angular deviation should not be greater than  $\pm 2^\circ$  in relation to the ideal position as otherwise the measuring accuracy will decrease.

An undisturbed flow progression is achieved if the sections in front of the sensor (inlet) and behind the sensor (outlet) are sufficiently long, absolutely straight and without any obstructions such as edges, seams, curves etc.

**For more details please see the instruction manuals of the consumption sensors.**

