

## Transmitter

# For gas density, temperature and pressure of SF<sub>6</sub> gas Model GDT-20, with Modbus® output

### Applications

- Permanent monitoring of the relevant gas condition parameters in closed tanks
- For internal and external SF<sub>6</sub>-insulated equipment

### Special features

- High-accuracy sensor technology
- Modbus® output protocol via RS-485 interface
- Ingress protection IP65
- Very good long-term stability and EMC characteristics
- Compact dimensions



Transmitter model GDT-20

### Description

The model GDT-20 transmitter is a multi-sensor system with digital output for the measurands of pressure and temperature. Based on these measured values, the condition-related data can be determined.

#### Permanent monitoring

In order to prevent system failures in switchgear and network outages, the permanent monitoring of the gas density is essential.

The GDT-20 transmitter calculates the current gas density from the pressure and temperature using a complex virial equation in the transmitter's powerful microprocessor. Changes in pressure resulting from thermal effects will be compensated by this and will not affect the output value.

#### Modbus® fieldbus

The RS-485 interface communicates using the Modbus® RTU protocol. The instrument's output parameters and their units can be configured and read according to requirements. The GDT-20 can be configured later by the customer for each defined SF<sub>6</sub> gas mixture with N<sub>2</sub> or CF<sub>4</sub>.

#### Signal stability

Due to its high long-term stability, the transmitter is maintenance-free and requires no recalibration. Due to the hermetically sealed weld seam and a measuring cell design without sealing elements, the permanent sealing of the measuring cell is ensured.

The EMC characteristics fulfil the IEC 61000-4-2 through to IEC 61000-4-6 standards and guarantee an interference-free data output.

## Specifications

Accuracy specifications		
<b>Accuracy</b>	The specifications only valid for pure SF <sub>6</sub> gas	
Density	±0.6 %, ±0.35 g/litre at -40 ... +80 °C [-40 ... +176 °F]	
Temperature	±1 K	
Pressure	-40 ... < 0 °C [-40 ... +32 °F]	±0.2 %, ±32 mbar
	0 ... 80 °C [32 ... 176 °F]	±0.06 %, ±10 mbar
Refresh rate		
Density	20 ms	
Temperature	20 ms	
Pressure	20 ms	
Long-term stability at reference conditions		
Temperature	≤ ±0.1 % of span/year	
Pressure	≤ ±0.05 % of span/year	

Measuring ranges	
<b>Density</b>	0 ... 60 g/litre (8.87 bar abs. at 20 °C [68 °F])
<b>Temperature</b>	-40 ... +80 °C [-40 ... +176 °F]
<b>Pressure</b>	0 ... 16 bar abs.
<b>Burst pressure</b>	52 bar abs.
<b>Overpressure limit</b>	Up to 30 bar abs.
<b>Pressure reference</b>	Absolute
<b>Unit</b>	Measured values with alternative units can be retrieved directly in the Modbus® registers
Density	g/litre, kg/m <sup>3</sup>
Temperature	°C, °F, K
Pressure	mbar, Pa, kPa, MPa, psi, N/cm <sup>2</sup> , bar (at 20 °C [68 °F])

Process connection	
<b>Thread</b>	G ½" B, male thread
<b>Material</b>	Stainless steel
<b>Transmission fluid</b>	Synthetic oil

Output signal	
<b>Voltage supply U<sub>B</sub></b>	DC 17 ... 30 V
<b>Power consumption</b>	Max. 0.5 W

Electrical connection	
<b>Connection type</b>	<ul style="list-style-type: none"> <li>■ Circular connector M12 x 1 (5-pin)</li> <li>■ Modbus® RTU via RS-485 interface</li> </ul>
<b>Modbus® functionality</b>	<ul style="list-style-type: none"> <li>■ Mixture ratio of SF<sub>6</sub> to N<sub>2</sub> or CF<sub>4</sub> (factory setting: 100 % SF<sub>6</sub> gas)</li> <li>■ Customer-specific sensor name</li> </ul>

## Pin assignment

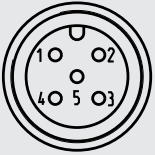
Circular connector M12 x 1 (5-pin)			
	1	-	-
	2	U <sub>B+</sub>	Voltage supply
	3	U <sub>B-</sub>	Ground
	4	A	Signal RS-485
	5	B	Signal RS-485

Material	
Process connection	Stainless steel
Case	Stainless steel

Operating conditions		
<b>Permissible temperature ranges</b>		
Standard	Operation	-40 ... +80 °C [-40 ... +176 °F]
	Storage	-40 ... +80 °C [-40 ... +176 °F]
Option	Operation	-60 ... +80 °C [-76 ... +176 °F]
	Storage	-60 ... +80 °C [-76 ... +176 °F]
<b>Permissible air humidity</b>	≤ 90 % r. h. (non-condensing)	
<b>Ingress protection IP (IP code) per IEC 60529</b>	IP65, only when plugged in and using mating connectors with the corresponding ingress protection	
<b>Electrical safety</b>	Protected against reverse polarity, protected against overvoltage	
<b>EMC tests</b>	Immunity per IEC 61000-4-3	30 V/m (80 MHz ... 2.7 GHz)
	Burst per IEC 61000-4-4	4 kV
	Surge immunity per IEC 61000-4-5	2 kV conductor to ground, 1 kV conductor to conductor
	ESD per IEC 61000-4-2	8 kV/15 kV, contact/air
	High-frequency fields per IEC 61000-4-6	10 V

## Approvals

Logo	Description	Country
	EAC	Eurasian Economic Community
	EMC directive	
-	<b>CRN</b> Safety (e.g. electr. safety, overpressure, ...)	Canada

## Manufacturer's information and certificates

Logo	Description
-	China RoHS directive

## Dimensions in mm

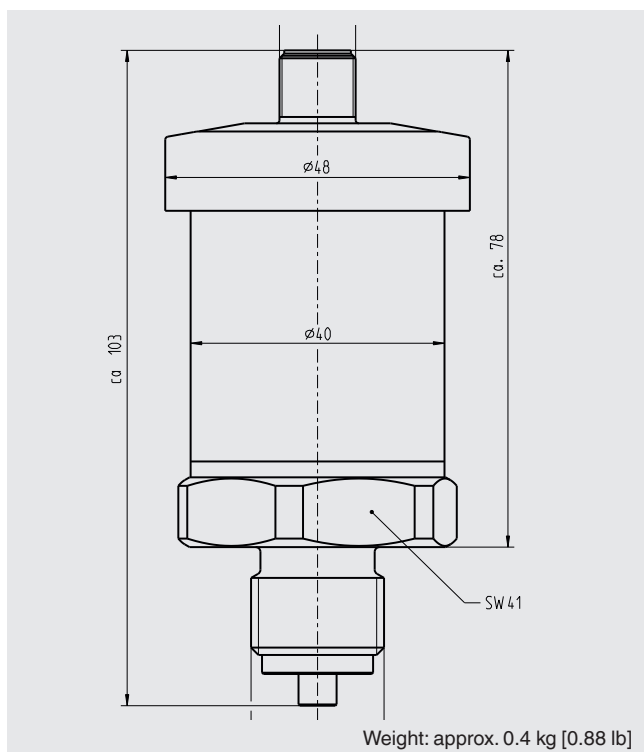

## Accessories

Designation	Order number
<b>Modbus® startup kit for configuration, consisting of:</b> <ul style="list-style-type: none"><li>■ Power supply unit for transmitter</li><li>■ Cable with M12 x 1 connector</li><li>■ Interface converter (RS-485 to USB)</li><li>■ USB cable type A to type B</li><li>■ Modbus® tool software on USB stick</li></ul>	14075896