

## Gas density switch with reference chamber Model GDS-RC-HV

### Applications

- High-voltage equipment
- Monitoring of SF<sub>6</sub> gas density of closed gas tanks
- Raising an alarm when defined limit values have been reached

### Special features

- Accurate isochore, temperature-compensated switching over the entire temperature range
- Increased plant safety through self-diagnostics
- Prepared for any alternative gases
- Very high long-term stability through welded reference gas volume



Gas density switch with reference chamber,  
model GDS-RC-HV

### Description

#### Gas density monitoring of electrical equipment

Gas density is a crucial operating parameter for high-voltage plants. If the required gas density is not present, safe operation of the plant cannot be guaranteed. The gas density switch model GDS-RC-HV warns reliably when the gas density, due to leakage, drops below the established values, even under extreme environmental conditions.

#### Operating principle

The model GDS-RC-HV works according to the reference gas principle. The reference gas enables accurate isochore switching and display over the entire temperature range. Temperature changes and atmospheric pressure variations do not affect the measurement.

#### Maximum plant safety through self-diagnostics

The welded reference chamber enables a very high long-term stability and eliminates drift. In the extremely unlikely case of leakage in the reference chamber, the plant operator is reliably warned by a switching signal of the instrument. The gas density monitor is maintenance-free.

#### Prepared for alternative gases

The model GDS-RC-HV can be used for any type of alternative gases and is capable of accurate isochore switching of these gases without any temperature effect.

## Specifications

General	
Measurement principle	Reference gas measurement
Measuring range	<ul style="list-style-type: none"> <li>■ 0 ... 10 bar abs. at 20 °C [68 °F] SF<sub>6</sub> gas</li> <li>■ 0 ... 12.5 bar abs. at 20 °C [68 °F] SF<sub>6</sub> gas</li> </ul>
Self-indication in case of malfunction	Integrated into the instrument, the switch contact is actuated in case of leakage in the reference chamber
Product label	Lasered onto the reference chamber, maximum weather resistance

Accuracy	
<b>Switching accuracy</b>	
-1 ... +5 bar at 20 °C [68 °F]	<ul style="list-style-type: none"> <li>■ ±70 mbar at calibration pressure at 20 °C [68 °F], gaseous phase</li> <li>■ ±100 mbar at calibration pressure at -30 ... +50 °C [-22 ... +122 °F], gaseous phase</li> </ul>
-1 ... +9 bar at 20 °C [68 °F]	<ul style="list-style-type: none"> <li>■ ±100 mbar at calibration pressure at 20 °C [68 °F], gaseous phase</li> <li>■ ±150 mbar at calibration pressure at -30 ... +50 °C [-22 ... +122 °F], gaseous phase</li> </ul>
-1 ... +11.5 bar at 20 °C [68 °F]	<ul style="list-style-type: none"> <li>■ ±150 mbar at calibration pressure at 20 °C [68 °F], gaseous phase</li> <li>■ ±200 mbar at calibration pressure at -30 ... +50 °C [-22 ... +122 °F], gaseous phase</li> </ul>

Switch contacts			
Switch model	Potential-free change-over contacts		
<b>Electrical connection</b>			
Electrical connection	12-pin TTI plug-in terminal		
Wire cross-section	<ul style="list-style-type: none"> <li>■ Min. 0.5 mm<sup>2</sup></li> <li>■ Max. 2.5 mm<sup>2</sup></li> </ul>		
Grounding	Grounding in cable socket available		
Quantity	<ul style="list-style-type: none"> <li>■ 1 micro switch</li> <li>■ 2 micro switches</li> <li>■ 3 micro switches</li> <li>■ 4 micro switches</li> </ul> Up to 4 micro switches possible as change-over contact		
Switching directions	<ul style="list-style-type: none"> <li>■ Falling density</li> <li>■ Rising density</li> </ul>		
Switch points	To customer specification, maximum difference of lowest to highest contact: 4 bar		
Electrical characteristics	<b>Switching voltage</b>	<b>Resistive load A</b>	<b>Inductive load A</b>
	≤ DC 30 V	5 <sup>1)</sup>	3 <sup>1)</sup>
	≤ DC 50 V	1	1
	≤ DC 75 V	0,75	0.75
	≤ DC 125 V	0,5	0.03
	≤ DC 250 V	0,25	0.03
	≤ AC 125 V	5 <sup>1)</sup>	2 <sup>1)</sup>
	≤ AC 250 V	5 <sup>1)</sup>	2 <sup>1)</sup>
Minimum switching voltage and current	12 V, 10 mA		
Calibration pressure	First switch point below filling pressure		
Switching function	Change-over contact		
Circuits	Galvanically isolated		
Maximum number of cycles	10,000 mechanical and electrical		
Insulation resistance contact	> 100 MOhm		

Switch contacts		
Switch hysteresis	Measuring range	Hysteresis level
	-1 ... +5 bar at 20 °C [68 °F]	Typical < 90 mbar <sup>2)</sup>
	-1 ... +7.5 bar at 20 °C [68 °F]	Typical < 150 mbar <sup>2)</sup>
	-1 ... +11.5 bar at 20 °C [68 °F]	Typical < 220 mbar <sup>2)</sup>
Lower switch hysteresis on request		

- 1) Only up to an ambient temperature of 70 °C [158 °F].  
At an ambient temperature of 70 ... 80 °C [158 ... 176 °F] the contacts may be operated with a maximum of 1 A.
- 2) In accordance with BS 6134:1991, rate of pressure change 1 % of end value per second.

Permissible ambient conditions	
Permissible ambient temperature	
Operating temperature	-40 ... +80 °C [-40 ... +176 °F], gaseous phase
Storage temperature	-50 ... +80 °C [-58 ... 176 °F]
Maximum load	
Minimum bursting strength	> 36 bar
Maximum overpressure	1.43 times the measuring range
Ingress protection	IP65, IP67
Permissible air humidity	≤ 95 % r. h. (non-condensing) Compensating diaphragm against condensation
Shock resistance	<ul style="list-style-type: none"> <li>■ 50 g/11 ms: no contact bouncing at a distance of 200 mbar from the switch point</li> <li>■ 150 g: no damage in all axes and directions</li> </ul>
Vibration resistance	4 g at a distance of 50 mbar from the switch point, no contact bouncing (20 ... 80 Hz)

EMC tests	
Dielectric strength	<ul style="list-style-type: none"> <li>■ 2 kV pin on grounding (case)</li> <li>■ 2 kV pin on pin (micro switch on micro switch)</li> <li>■ 1 kV pin on pin within micro switches - 1 minute</li> </ul>
Lightning	7 kV x 1.2/50 µs

Leak tightness	
Process connection	≤ 1 x 10 <sup>-8</sup> mbar x l/s
Bellows sealing	≤ 1 x 10 <sup>-8</sup> mbar x l/s

Materials	
Wetted materials	
Reference chamber (pressure element)	Stainless steel, filling with reference gas
Process connection	G ½ B per EN 837, axial or radial, stainless steel, spanner flats 22 mm Other connections and connection locations on request
Non-wetted materials	
Case and cover	Aluminium die-casting, powder-coated
Cable gland M25 x 1.5	Plastic, sealing range 5 ... 13 mm; (optional 8 ... 17 mm) Tightening torque: 8 Nm

# Dimensions in mm

## Back mount version

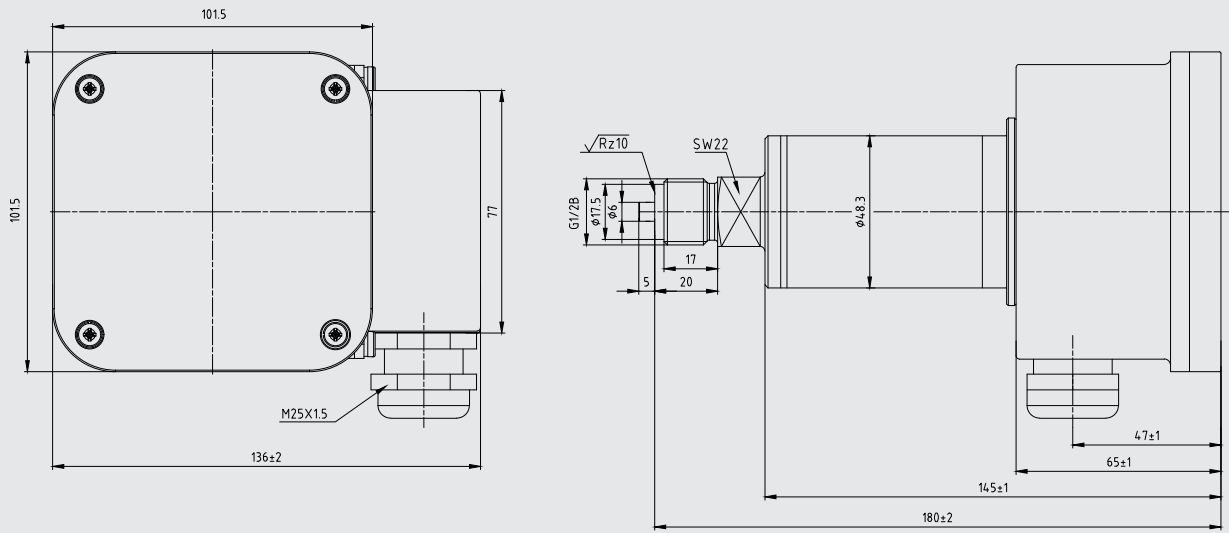

Weight: < 1,250 g

## Vertical version

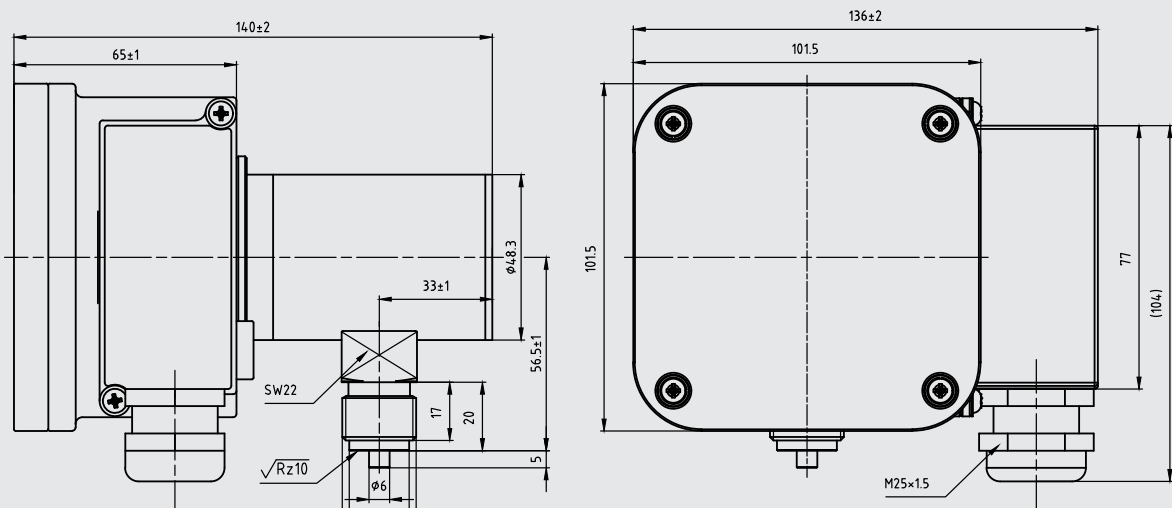

Weight: < 1,250 g

## Approvals

Logo	Description	Country
	<b>EU declaration of conformity</b> <ul style="list-style-type: none"><li>■ Low voltage directive</li><li>■ RoHS directive</li></ul>	European Union

## Manufacturer's information and certifications

Logo	Description
-	China RoHS directive