

Series 33X

Piezoresistive pressure transmitters with maximum accuracy of 0,01 %FS

Features

- Maximum accuracy/precision down to 0,01 %FS
- RS485 interface can be combined with analog interface
- Analog interface rangeable by RS485 interface (turn-down)
- Modbus RTU protocol for process values and configuration
- Highest long-term stability

Technology

- Insulated and encapsulated piezoresistive pressure sensor
- High-quality pressure transducers and tried-and-tested mathematical compensation

Typical applications

- Laboratory use
- Test benches
- Gauge standard
- Precision measurements
- Industrial applications



Accuracy

± 0,05 %FS

Total error band

± 0,1 %FS @ -10...80 °C

Pressure ranges

0...0,3 to 0...1000 bar



Series 33X

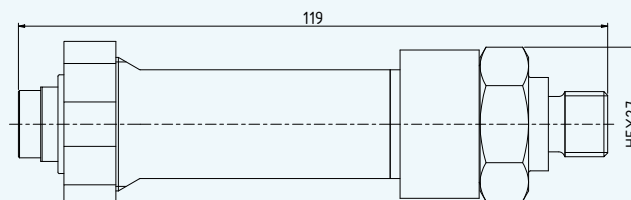

Series 33X – Specifications

Standard pressure ranges

Relative pressure PR		Proof pressure
0...0,3	-0,3...0,3	3
0...1	-1...1	
0...3	-1...3	9
0...6	-1...6	18
0...10	-1...10	30
0...16	-1...16	48
0...30	-1...30	90
bar rel.		bar
Reference pressure at ambient pressure		Based on reference pressure

Absolute pressure PAA	Absolute pressure PA	Proof pressure
0,8...1,2		3
0...1	0...1	
0...3	0...3	9
0...6	0...6	18
0...10	0...10	30
0...16	0...16	48
0...30	0...30	90
0...60	0...60	180
0...100	0...100	300
0...300	0...300	600
0...700	0...700	1100
0...1000	0...1000	1100
bar abs.	bar	bar
Reference pressure at 0 bar abs. (vacuum)	Reference pressure at 1 bar abs.	Based on reference pressure

All intermediate ranges for the analog interface can be ranged (turn-down) from the standard ranges without surcharge. Smallest range: 0,1 bar. Negative and further +/- ranges also possible. Optionally: adjust directly to intermediate ranges

Performance

Pressure

Digital nonlinearity	$\leq \pm 0,02$ %FS	Best fitted straight line (BFSL)
Accuracy @ RT (20...25 °C)	$\leq \pm 0,05$ %FS	Nonlinearity (best fitted straight line BFSL), pressure hysteresis, non-repeatability, zero point deviation and amplification deviation
Total error band (10...40 °C)	$\leq \pm 0,05$ %FS	Max. deviation within the compensated pressure and temperature range
Total error band (-10...80 °C)	$\leq \pm 0,1$ %FS	Max. deviation within the compensated pressure and temperature range Experience shows that, outside the compensated temperature range, the total error band in the ambient temperature range is expanded by 0,1 %FS
Compensated temperature range	10...40 °C	Extended room temperature range RT
	-10...80 °C	Other, optional temperature ranges within -40...125 °C possible
Note	The compensated temperature ranges with the corresponding total error band are ordering options.	
Analog interface additional deviation	$\leq \pm 0,05$ %FS	Based on accuracy @ RT and the total error band
Long-term stability	Typ. $\pm 0,05$ %FS	Per year under reference conditions, yearly recalibration recommended
	Max. $\pm 0,10$ %FS	
Position dependency	$\leq \pm 2$ mbar	Calibrated in vertical installation position with pressure connection facing downwards
Resolution	0,0005 %FS	Digital
Signal stability	0,0025 %FS	Digital noise-free
Internal measurement rate	≥ 1800 Hz	For version «3-wire + digital (0...10 V, 0...5 V)» > 6000 Hz
Pressure range reserve	± 10 %	Outside the pressure range reserve, +Inf/-Inf is displayed. If there is an error in the device, NaN is displayed
Vacuum resistance	For operating pressures $\leq 0,1$ bar abs., a vacuum-optimised version is recommended	
Note	For pressure ranges < 1 bar, all data apply with reference to a full-range signal (FS) of 1 bar	

Series 33X – Specifications

Temperature

Accuracy	$\leq \pm 2 \text{ }^\circ\text{C}$	The temperature is measured on the pressure sensor (silicon chip) that sits behind the metallic separating diaphragm The values are valid within the compensated temperature range
Resolution	$\leq 0,01 \text{ }^\circ\text{C}$	
Internal measurement rate	$> 10 \text{ Hz}$	

Increased Precision / Accuracy (optional)

If customers choose, KELLER can achieve the highest degree of reproducibility (precision) for certain products by increasing the amount of measurement work it undertakes and selecting corresponding pressure transducers. In addition, some products can be adjusted to their higher accuracy pressure sources by an accredited calibration laboratory. The specifications for increased precision only refer to the digital interface RS485. See the more comprehensive descriptions below for more details.

Limitations:

- Only for absolute pressure PAA / PA
- Only for standard pressure ranges $\geq 10 \text{ bar}$
- Analog output 4...20 mA excluded

Precision (10...40 °C)	$\leq \pm 0,01 \text{ \%FS}$	With KELLER calibration certificate ex works
	$\leq \pm 0,025 \text{ \%FS}$	
Accuracy @ RT	$\leq \pm 0,01 \text{ \%FS}$	With DakkS (German accreditation body) certificate issued by external calibration laboratory
	$\leq \pm 0,025 \text{ \%FS}$	

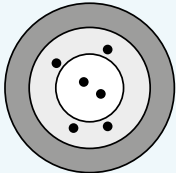
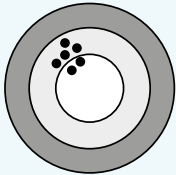
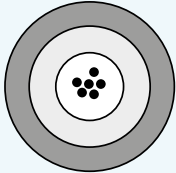
	<p>Accuracy $\pm 0,05 \text{ \%FS}$, with KELLER calibration certificate ex works (standard)</p> <p>Keller uses pressure sources to calibrate its products that are at least four times more accurate than the product to be tested. This enables us to produce products in our factory with an absolute accuracy of up to $\pm 0,05 \text{ \%FS}$.</p>
	<p>Precision $\pm 0,01 \text{ \%FS} / \pm 0,025 \text{ \%FS}$, with KELLER calibration certificate ex works</p> <p>Additional measurement work and selection of a specific pressure transducer means that optimum repeatability is guaranteed for selected pressure transmitters and digital manometers. Owing to the residual measurement uncertainty of the pressure sources used at its factory, KELLER cannot provide any verification of measurement accuracy at scales below $\pm 0,05 \text{ \%FS}$ for these ultra-precise devices. KELLER therefore uses the term "precision" to denote the ability of a pressure transmitter or manometer to repeat measured values within a tolerance of $0,01 \text{ \%FS}$ based on the pressure sources used at the factory.</p>
	<p>Accuracy $\pm 0,01 \text{ \%FS} / \leq \pm 0,025 \text{ \%FS}$ with DakkS (German accreditation body) certificate, issued by an external accredited calibration laboratory</p> <p>By calibrating the zero point and performing amplification via the digital interface, an accredited calibration laboratory (ilac.org) can adapt ultra-precise KELLER products to their more accurate pressure sources and record the results.</p> <p>External calibration to an accuracy of up to $\pm 0,01 \text{ \%FS}$ is performed in accordance with the guidelines set out by the German Calibration Service (DKD) and is conducted under reference conditions without any consideration of long-term effects.</p>

Series 33X – Specifications

Electrical data

Connectivity	Digital	2-wire + digital	3-wire + digital		
			0...10 V	0...5 V	0,1...2,5 V
Analog interface		4...20 mA	0...10 V	0...5 V	0,1...2,5 V
Digital interface	RS485	RS485	RS485	RS485	RS485
Power supply	3,2...32 VDC	8...32 VDC	13...32 VDC	8...32 VDC	3,2...32 VDC
Power consumption (without communication)	< 8 mA	3,5...22,5 mA	< 8 mA	< 8 mA	< 8 mA
RS485 voltage insulation	± 32 VDC	± 18 VDC	± 32 VDC	± 32 VDC	± 32 VDC
Note	Disturbance of the 4...20 mA signal occurs during communication via the digital interface 3-wire types are suitable for simultaneous operation of the analog and digital interface				

Start-up time (power supply ON)	< 250 ms
Overtoltage protection and reverse polarity	± 32 VDC
GND case insulation	> 10 MΩ @ 300 VDC

Analog interface

Load resistance	< (U - 8 V)/25 mA	2-wire
	> 5 kΩ	3-wire
Limiting frequency	≥ 300 Hz	2-wire
	≥ 1000 Hz	3-wire (0,1...2,5 V)
	≥ 1000 Hz	3-wire (0...10 V, 0...5 V)
Note	Filter properties can be adjusted by the customer	

Digital interface

Type	RS485	Half-duplex
Communication protocols	Modbus RTU	
	KELLER bus protocol	Proprietary
Identification	Class.Group: 5.24	Standard settings: bus address 1, baud rate 9600 bit/s Other default settings available on request. Can be reconfigured via software by the customer later
Unit of pressure	Bar	
Unit of temperature	°C	
Data type	Float32 and Int32	
Baud rates	9600 and 115'200 bit/s	
Lines	up to 1,2 km	

Electrical connection

Plug type	Binder series 723	DIN EN 61076-2-106, 5-pin
	M12 x 1	DIN EN 61076-2-101, A-coded, 5-pin
	Souriau series 8525	MIL-STD-1669
	GSP (without RS485)	EN 175301-803-A (DIN 43650)
Cable	ø 5,8 mm, PE sheath	5-wire, cable gland
Standard cable lengths	2 m, 5 m	Others on request

Electromagnetic compatibility

CE-conformity as per 2014/30/EU (EMC)	EN 61326-1/EN 61326-2-3/EN 61000-6-1/EN 61000-6-2/EN 61000-6-3/EN 61000-6-4
---------------------------------------	---

Series 33X – Specifications

Mechanical data

Materials in contact with media

Pressure connection	Stainless steel AISI 316L		Others on request
Pressure transducer separating diaphragm	Stainless steel AISI 316L		
Pressure transducer seal (internal)	FKM	For media temperatures <-20 °C FVMQ (70 Shore, -60...175 °C) is used Optional: EPDM (-40...150 °C)	Others on request
Pressure connection seal (external)	FKM (75 Shore, -20...200 °C)		

Other materials

Pressure transducer oil filling	Silicone oil	Others on request
---------------------------------	--------------	-------------------

Further details

Pressure connection	A wide range of pressure connections are available	See dimensions and options
Weight (excluding cable)	Between 130 g and 250 g	Depends on version

Ambient conditions

Media temperature range	-20...125 °C	Optionally: -40...125 °C	Icing not permitted
Ambient temperature range	-20...85 °C	Optionally: -40...85 °C	
Storage temperature range	-20...85 °C	Optional: -40...85 °C	
Protection	IP67	Binder series 723	For relative pressure, use a cable with integrated capillary
	IP65	GSP EN175301-803-A	
	IP65	Souriau series 8525	
	IP67	M12 x 1	For relative pressure IP54
	IP67	Cable gland	For relative pressure, a cable with integrated capillary is used
Notes	<ul style="list-style-type: none"> Degrees of protection are valid with the corresponding mating plug. The design implementation of the ventilation for relative pressure versions can be found in the respective technical drawing. 		
Vibration resistance	10 g, 10...2000 Hz, ±10 mm	IEC 60068-2-6	
Shock endurance	50 g, 11 ms	IEC 60068-2-27	
Pressure endurance @ RT (20...25 °C)	> 10 million pressure cycles	0...100 %FS	For pressures < 600 bar only
Notes	For ultra-dynamic applications, the fully welded 23SX series without movable interior parts is recommended		

Series 33X – Dimensions and options

Electrical connections

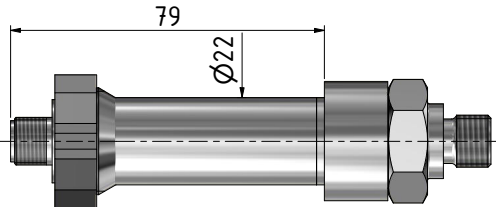

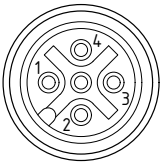
M12	2-wire	3-wire
M12 x 1	4...20 mA	0...max. 10 V
	1 OUT/GND	1 GND
	2 n.c.	2 +OUT
	3 +Vs	3 +Vs
	4 RS485A	4 RS485A
	5 RS485B	5 RS485B

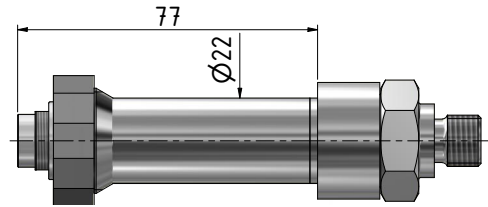

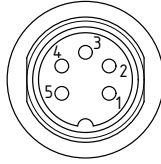
Binder series 723	2-wire	3-wire
M16 x 0,75	4...20 mA	0...max. 10 V
	1 OUT/GND	1 GND
	2 n.c.	2 +OUT
	3 +Vs	3 +Vs
	4 RS485A	4 RS485A
	5 RS485B	5 RS485B

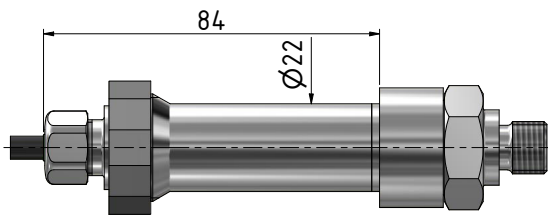

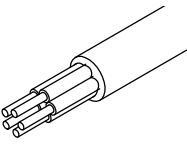
Cable gland	2-wire	3-wire
Cable ø 5,8	4...20 mA	0...max. 10 V
	WH OUT/GND	WH GND
	RD n.c.	RD +OUT
	BK +Vs	BK +Vs
	BU RS485A	BU RS485A
	YE RS485B	YE RS485B
	Shield on CASE	Shield on CASE

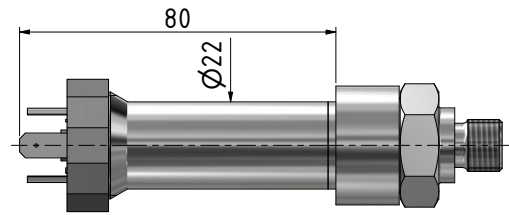

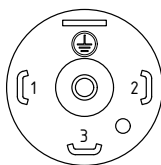
GSP EN 175301-803-A	2-wire	3-wire
□ 18	4...20 mA	0...max. 10 V
	1 OUT/GND	1 GND
	2 n.c.	2 +OUT
	3 +Vs	3 +Vs
	⊥ CASE	⊥ CASE

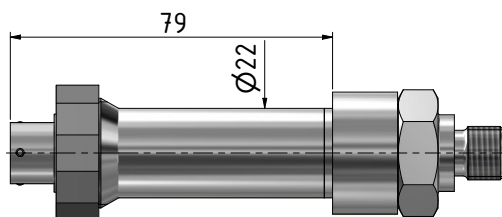

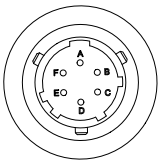
Souriau series 8525	2-wire	3-wire
	4...20 mA	0...max. 10 V
	C OUT/GND	C GND
	B n.c.	B +OUT
	A +Vs	A +Vs
	D RS485A	D RS485A
	F RS485B	F RS485B
	Shield on CASE	Shield on CASE

Series 33X – Dimensions and options

Available pressure connections

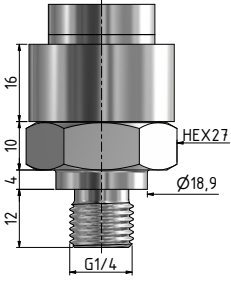
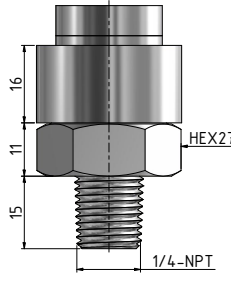
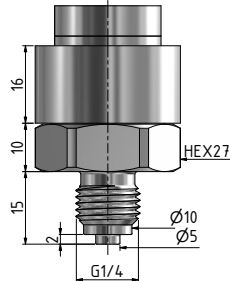
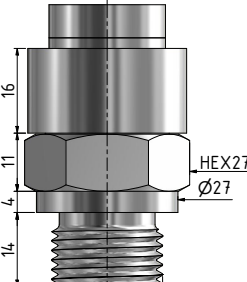
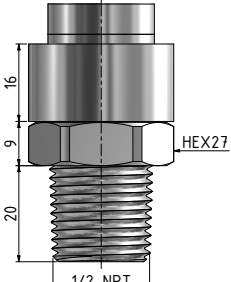
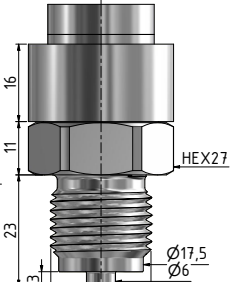
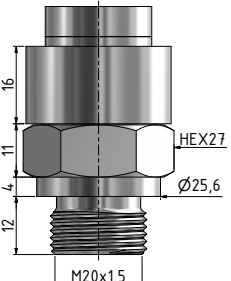
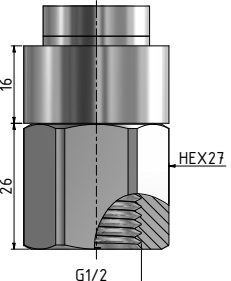
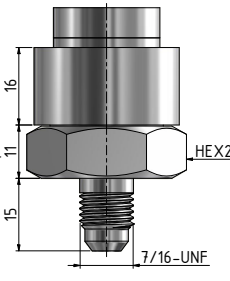
<p>G1/4</p>  <p>DIN EN ISO 1179-2</p>	<p>1/4-18NPT</p>  <p>ASME/ANSI B 120.1</p>	<p>G1/4 "Mano"</p>  <p>DIN EN 837</p>
<p>G1/2</p>  <p>DIN EN ISO 1179-2</p>	<p>1/2-14NPT</p>  <p>ASME/ANSI B 120.1</p>	<p>G1/2 "Mano"</p>  <p>DIN EN 837</p>
<p>M20 x 1,5</p>  <p>DIN EN ISO 9974-2</p>	<p>G1/2 female</p>  <p>ISO 228-1</p>	<p>7/16-20UNF 45° / SAE JIC 37°</p>  <p>ISO 12151-5, pressure ranges restricted</p>

Other pressure connections available on request.

Series 33X – Dimensions and options

Other customer-specific options

- Other compensated pressure ranges
- Other compensated temperature ranges within -40...125 °C
- Other electrical connections
- Other pressure connections
- Parts that come into contact with media made from Hastelloy C-276, Inconel 718 or titanium
- O-rings made of other materials
- Other oil filling types for pressure transducers: e.g. special oils for oxygen applications
- Vacuum-optimised version for operating pressures $\leq 0,1$ bar abs.
- Integration of application-specific calculations
- Modifications to customer-specific applications

Examples of similar products

- Series PD-33X: Differential pressure transmitters with a very high level of accuracy
- Series 33Xc: Pressure transmitters with maximum accuracy of up to 0,01 %FS and CANopen interface
- Series 35X: Pressure transmitters with front-flush metal diaphragm and very high level of accuracy
- Series 23SX: Pressure transmitters with fully welded design and no internal seals
- OEM series: Pressure transducers with electronics (e.g. series 10LX or 20SX with thread) for integration in one's own systems

Series 33X – Software, scope of delivery and accessories

Modbus interface

The X-line products have a digital interface (RS485 half-duplex), which supports the MODBUS RTU and KELLER bus protocols. Details of the communication protocols can be found at www.keller-druck.com. Documentation, a Dynamic Link Library (DLL) and various programming examples are available for integrating the communication protocol into your own software.

Interface converters

The connection to a computer is established via an RS485-USB interface converter. To ensure smooth operation, we recommend the K-114 with the corresponding mating plug, robust driver module, fast RX/TX switching and connectable bias and terminating resistors.

"CCS30" software

The licence-free software CCS30 is used to carry out configurations and record measured values.

Measurement collection

- Live visualisation
- Adjustable measuring and storage interval
- Export function
- Parallel recording in bus operation
- Up to 100 measured values per second





Configuration

- Call up of information (pressure and temperature range, software version, serial number etc.)
- Readjustment of zero point and amplification
- Rescaling of analog output (unit, pressure range)
- Adjustment of low-pass filter
- Selection of instrument address and baud rate

Scope of delivery

KELLER test report	Mating plug to Binder 723	Female connector to DIN43650	Copper seal for G 1/4 «mano» with centring pin	Copper seal for G 1/2 «mano» with centring pin
				

Accessories

Calibration certificate	Interface converter	Mating plug to M12	Mating plug to bayonet plug
			
Issued by the external calibration laboratory of the German accreditation body DAkkS or the Swiss accreditation body SAS	K-114 <ul style="list-style-type: none"> • Analog measurement 0...10 V and 4...20 mA • 12 V measuring device supply via USB • USB interface electrically isolated • Bias and terminating resistors can be activated 	Connection options <ul style="list-style-type: none"> • E.g. K-114-B with cable outlet instead of screw-type terminals for Binder series 723 (5-pin)≠ • Various adapter cables available 	<ul style="list-style-type: none"> • Angled socket, cable 5 m PN 602515.0093 • Angled socket, cable 2 m PN 602515.0094 • Female connector, cable 5 m PN 602515.0095 • Female connector, cable 2 m PN 602515.0096