

Resistance thermometer For additional thermowell Model TR10-B

WIKA data sheet TE 60.02



for further approvals
see page 15

Applications

- Machine building, plant and vessel construction
- Energy and power plant technology
- Chemical industry
- Food and beverage industry
- Sanitary, heating and air-conditioning technology

Special features

- Sensor ranges from -196 ... +600 °C [-320 ... +1,112 °F]
- For mounting in all standard thermowell designs
- Spring-loaded measuring insert (replaceable)
- Pt100 or Pt1000 sensors
- Explosion-protected versions are available for many approval types (see page 2)

Description

Resistance thermometers in this series can be combined with a large number of thermowell designs. Operation without thermowell is only recommended in certain applications.

A wide variety of possible combinations of Pt100 or Pt1000 sensor, connection head, insertion length, neck length, connection to thermowell etc. are available for the thermometers; suitable for any thermowell dimension and any application.

A large number of different explosion-protected approvals are available for the TR10-B.

Optionally we can fit analogue or digital transmitters from the WIKA range into the connection head of the TR10-B.



Fig. left: Model TR10-B with BSZ connection head
Fig. right: Model TR10-B with 1/4000 connection head

Representation of the components

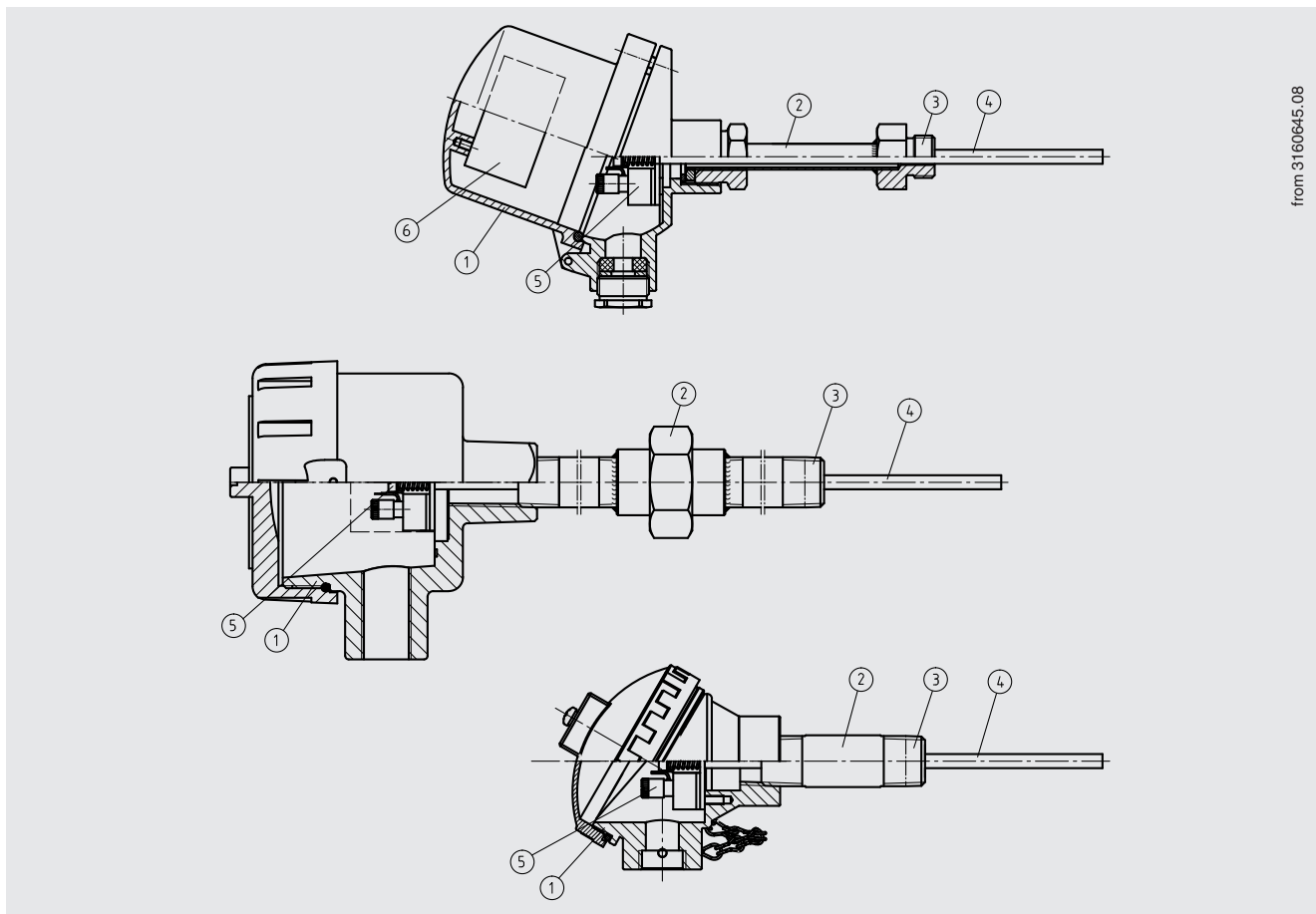

from 31606/45.08

Legend:

- ① Connection head
- ② Neck tube
- ③ Connection to thermowell
- ④ Measuring insert (TR10-A)
- ⑤ Terminal block/transmitter (option)
- ⑥ Transmitter (option)

Overview of approvals for explosion protection

Approval	Explosion protection				
	Ex i (gas) Zone 0, 1, 2	Ex i (dust) Zone 20, 21, 22	Ex e (gas) Zone 1, 2	Ex t (dust) Zone 21, 22	Ex nA (gas) Zone 2
ATEX	x	x	x	x	x
IECEX	x	x	x	x	x
EAC	x	x	-	-	x
Ex Ukraine	x	x	-	-	-
INMETRO	x	x	-	-	-
CCC	x	x	x	-	x
KCs	x	-	-	-	-
PESO	x	-	-	-	-

→ For detailed information, see page 15

Measuring element

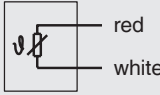
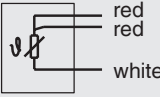
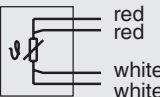
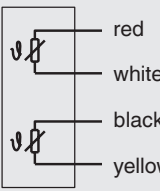
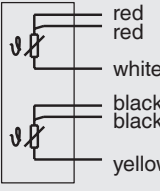
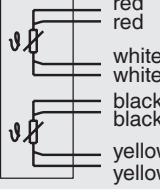
Measuring element		
Type of measuring element	Pt100, Pt1000 ¹⁾	
Measuring current	0.1 ... 1.0 mA	
Connection method		
Single elements	1 x 2-wire	 red white
	1 x 3-wire	 red red white
	1 x 4-wire	 red red white white
Dual elements	2 x 2-wire	 red white black yellow
	2 x 3-wire	 red red white black black yellow
	2 x 4-wire ²⁾	 red red white white black black yellow yellow
Validity limits of the class accuracy in accordance with EN 60751		
Class B	Wire-wound	■ -196 ... +600 °C ■ -196 ... +450 °C
	Thin-film	■ -50 ... +500 °C ■ -50 ... +250 °C
Class A ³⁾	Wire-wound	-100 ... +450 °C
	Thin-film	-30 ... +300 °C
Class AA ³⁾	Wire-wound	-50 ... +250 °C
	Thin-film	0 ... 150 °C

1) Pt1000 only available as a thin-film measuring resistor

2) Not for 3 mm diameter

3) Not with 2-wire connection method







→ For detailed specifications for Pt100 sensors, see Technical information IN 00.17 at www.wika.com.

The table shows the temperature ranges listed in the respective standards, in which the tolerance values (class accuracies) are valid.

- The combinations of a 2-wire connection with class A or class AA are not permissible, since the lead resistance of the MI cable and the connection lead negates the higher sensor accuracy.
- When using a 3-wire connection, we recommend not to exceed a probe length, including the connection cable, of approx. 30 m.
- Longer probe/cable lengths should be designed with a 4-wire connection.

Connection head

■ European designs per EN 50446 / DIN 43735

Model	Material	Cable entry thread size	Ingress protection (max.) ¹⁾ IEC/EN 60529	Cap	Surface	Connection to neck tube
 BS	Aluminium	■ M20 x 1.5 ■ ½ NPT	IP65 ³⁾	Flat cover with 2 screws	Blue, painted (RAL 5022)	■ M24 x 1.5 ■ ½ NPT
 BSZ	Aluminium	■ M20 x 1.5 ■ ½ NPT	IP65 ³⁾	Spherical hinged cover with cylinder head screw	Blue, painted (RAL 5022)	■ M24 x 1.5 ■ ½ NPT
BSZ-K	Plastic	■ M20 x 1.5 ■ ½ NPT	IP65	Spherical hinged cover with cylinder head screw	Black	M24 x 1.5
 BSZ-H	Aluminium	■ M20 x 1.5 ■ ½ NPT	IP65 ³⁾	Raised hinged cover with cylinder head screw	Blue, painted (RAL 5022)	■ M24 x 1.5 ■ ½ NPT
BSZ-H (2 x cable outlet)	Aluminium	■ 2 x M20 x 1.5 ■ 2 x ½ NPT	IP65 ³⁾	Raised hinged cover with cylinder head screw	Blue, painted (RAL 5022)	M24 x 1.5
BSZ-H / DIH10²⁾	Aluminium	■ M20 x 1.5 ■ ½ NPT	IP65	Raised hinged cover with cylinder head screw	Blue, painted (RAL 5022)	■ M24 x 1.5 ■ ½ NPT
BSZ-HK	Plastic	■ M20 x 1.5 ■ ½ NPT	IP65	Raised hinged cover with cylinder head screw	Black	M24 x 1.5
 BSS	Aluminium	■ M20 x 1.5 ■ ½ NPT	IP65	Spherical hinged cover with clamping lever	Blue, painted (RAL 5022)	■ M24 x 1.5 ■ ½ NPT
 BSS-H	Aluminium	■ M20 x 1.5 ■ ½ NPT	IP65	Raised hinged cover with clamping lever	Blue, painted (RAL 5022)	■ M24 x 1.5 ■ ½ NPT
 BVS	Stainless steel	M20 x 1.5	IP65	Precision-cast screw-on lid	Natural finish, electropolished	M24 x 1.5

Model	Explosion protection					
	Without	Ex i (gas) Zone 0, 1, 2	Ex i (dust) Zone 20, 21, 22	Ex e (gas) Zone 1, 2	Ex t (dust) Zone 21, 22	Ex nA (gas) Zone 2
BS	x	x	x	-	-	-
BSZ	x	x	x	x ⁴⁾	x ⁴⁾	x ⁵⁾
BSZ-H	x	x	x	x ⁴⁾	x ⁴⁾	x ⁵⁾
BSZ-H (2 x cable outlet)	x	x	x	x ⁴⁾	x ⁴⁾	x ⁵⁾
BSZ-H / DIH10²⁾	x	x	-	-	-	-
BSS	x	x	-	-	-	-
BSS-H	x	x	-	-	-	-
BVS	x	x	-	-	-	-
BSZ-K	x	x	-	-	-	-
BSZ-HK	x	x	-	-	-	-

1) IP ingress protection of the connection head. The IP ingress protections of the complete instrument TR10-B must not inevitably correspond to the connection head.

2) DIH10 LED display



3) Ingress protections, describing temporary or permanent immersion, on request

4) Only ATEX and CCC

5) Only ATEX, CCC and EAC

Further thread sizes on request

■ North American designs

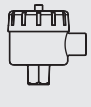
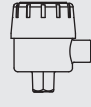
Model	Material	Cable entry thread size	Ingress protection (max.) ¹⁾ IEC/EN 60529	Cap	Surface	Connection to neck tube
	KN4-A	Aluminium	■ ½ NPT ■ M20 x 1.5	IP65 ³⁾	Screw-on lid	Blue, painted (RAL 5022) ■ M24 x 1.5 ■ ½ NPT
	KN4-P ²⁾	Polypropylene	½ NPT	IP65 ³⁾	Screw-on lid	White ½ NPT
	1/4000 F	Aluminium	■ ½ NPT ■ ¾ NPT ■ M20 x 1.5	IP66 ³⁾	Screw-on lid	Blue, painted (RAL 5022) ½ NPT
	1/4000 S	Stainless steel	■ ½ NPT ■ ¾ NPT ■ M20 x 1.5	IP66 ³⁾	Screw-on lid	Natural finish ½ NPT
	7/8000 W	Aluminium	■ ½ NPT ■ ¾ NPT ■ M20 x 1.5	IP66 ³⁾	Screw-on lid	Blue, painted (RAL 5022) ½ NPT
	7/8000 S	Stainless steel	■ ½ NPT ■ ¾ NPT ■ M20 x 1.5	IP66 ³⁾	Screw-on lid	Natural finish ½ NPT
	7/8000 W / DIH50 ⁴⁾	Aluminium	■ ½ NPT ■ ¾ NPT ■ M20 x 1.5	IP66 ³⁾	Screw-on lid	Blue, painted (RAL 5022) ½ NPT
	7/8000 S / DIH50 ⁴⁾	Stainless steel	■ ½ NPT ■ ¾ NPT ■ M20 x 1.5	IP66 ³⁾	Screw-on lid	Natural finish ½ NPT

Model	Explosion protection					
	Without	Ex i (gas) Zone 0, 1, 2	Ex i (dust) Zone 20, 21, 22	Ex e (gas) Zone 1, 2	Ex t (dust) Zone 21, 22	Ex nA (gas) Zone 2
KN4-A	x	x	-	-	-	-
KN4-P ²⁾	x	-	-	-	-	-
1/4000 F	x	x	x	x	x	x
1/4000 S	x	x	x	x	x	x
7/8000 W	x	x	x	x	x	x
7/8000 S	x	x	x	x	x	x
7/8000 W / DIH50 ⁴⁾	x	x	x	-	-	-
7/8000 S / DIH50 ⁴⁾	x	x	x	-	-	-

1) IP ingress protection of the connection head. The IP ingress protections of the complete instrument TR10-B must not inevitably correspond to the connection head.

2) On request

3) Suitable sealing/cable gland required

4) LC display DIH50

Connection head with digital display



Connection head BSZ-H with LED display model DIH10

→ see data sheet AC 80.11



Connection head 7/8000 W with LC display model DIH50

→ see data sheet AC 80.10

To operate the digital displays, a transmitter with a 4 ... 20 mA output is always required.

Cable entry

Cable entry	Colour	Ingress protection (max.) IEC/EN 60529 ¹⁾	Cable entry thread size	Min./max. ambient temperature
 Standard cable entry ²⁾	Natural finish	IP65	<ul style="list-style-type: none"> ■ M20 x 1.5 ■ ½ NPT 	-40 ... +80 °C
 Plastic cable gland (cable Ø 6 ... 10 mm) ²⁾	<ul style="list-style-type: none"> ■ Black ■ Grey 	IP66 ³⁾	<ul style="list-style-type: none"> ■ M20 x 1.5 ■ ½ NPT 	-40 ... +80 °C
 Plastic cable gland (cable Ø 6 ... 10 mm), Ex e ²⁾	<ul style="list-style-type: none"> ■ Light blue ■ Black 	IP66 ³⁾	<ul style="list-style-type: none"> ■ M20 x 1.5 ■ ½ NPT 	<ul style="list-style-type: none"> ■ -20 ... +80 °C ■ -40 ... +70 °C
 Nickel-plated brass cable gland (cable Ø 6 ... 12 mm)	Natural finish	IP66 ³⁾	<ul style="list-style-type: none"> ■ M20 x 1.5 ■ ½ NPT 	-60 ⁴⁾ / -40 ... +80 °C
	Nickel-plated brass cable gland (cable Ø 6 ... 12 mm), Ex e	Natural finish	IP66 ³⁾	<ul style="list-style-type: none"> ■ M20 x 1.5 ■ ½ NPT
 Stainless steel cable gland (cable Ø 7 ... 12 mm)	Natural finish	IP66 ³⁾	<ul style="list-style-type: none"> ■ M20 x 1.5 ■ ½ NPT 	-60 ⁴⁾ / -40 ... +80 °C
	Stainless steel cable gland (cable Ø 7 ... 12 mm), Ex e	Natural finish	IP66 ³⁾	<ul style="list-style-type: none"> ■ M20 x 1.5 ■ ½ NPT
 Plain threaded	-	IP00	<ul style="list-style-type: none"> ■ M20 x 1.5 ■ ½ NPT 	-
 2 x plain threaded ⁵⁾	-	IP00	<ul style="list-style-type: none"> ■ 2 x M20 x 1.5 ■ 2 x ½ NPT 	-
 Junction box M12 x 1 (4-pin) ⁶⁾	-	IP65	M20 x 1.5	-40 ... +80 °C
 Sealing plugs for shipping	Transparent	-	<ul style="list-style-type: none"> ■ M20 x 1.5 ■ ½ NPT 	-40 ... +80 °C

1) IP ingress protection of the cable gland. The IP ingress protections of the complete instrument TR10-B must not inevitably correspond to the cable gland.

2) Not available for BVS connection head

3) Ingress protections, describing temporary or permanent immersion, on request

4) Special version on request (explosion-protected versions only available with specific approvals)

5) Only for BSZ-H connection head

6) Not available for ½ NPT thread size cable entry

Cable entry	Explosion protection					
	Without	Ex i (gas) Zone 0, 1, 2	Ex i (dust) Zone 20, 21, 22	Ex e (gas) Zone 1, 2	Ex t (dust) Zone 21, 22	Ex nA (gas) Zone 2
Standard cable entry ¹⁾	x	x	-	-	-	-
Plastic cable gland ¹⁾	x	x	-	-	-	-
Plastic cable gland (light blue), Ex e ¹⁾	x	x	x	-	-	-
Plastic cable gland (black), Ex e ¹⁾	x	x	x	x	x	x
Brass cable gland, nickel-plated	x	x	x	-	-	-
Brass cable gland, nickel-plated, Ex e	x	x	x	x	x	x
Stainless steel cable gland	x	x	x	-	-	-
Stainless steel cable gland, Ex e	x	x	x	x	x	x
Plain threaded	x	x	x ⁵⁾	x ⁵⁾	x ⁵⁾	x ⁵⁾
2 x plain threaded ²⁾	x	x	x ⁵⁾	x ⁵⁾	x ⁵⁾	x ⁵⁾
Junction box M12 x 1 (4-pin) ³⁾	x	x ⁴⁾	x ⁴⁾	-	-	-
Sealing plugs for shipping	Not applicable, transport protection ⁵⁾					

1) Not available for BVS connection head

2) Only for BSZ-H connection head

3) Not available for ½ NPT thread size cable entry

4) With appropriate mating connector connected

5) Suitable cable gland required for operation

Measuring insert

Measuring insert		
Versions	Vibration-resistant, sheathed measuring cable (MI cable)	
Standard	Standard soldering lugs	
Option	Recessed soldering lugs	
Optimal heat transfer	Requirement <ul style="list-style-type: none"> ■ Correct measuring insert length ■ Correct measuring insert diameter 	
	Bore diameter of the thermowell	Max. 1 mm larger than measuring insert diameter
	Joint width	For joint width > 0.5 mm between thermowell and measuring insert: → Negative impact on heat transfer → Unfavourable response behaviour of the thermometer
Insertion length	When fitting the measuring insert into a thermowell, it is very important to determine the correct insertion length (= thermowell length for bottom thicknesses of ≤ 5.5 mm). In order to ensure that the measuring insert is firmly pressed down onto the bottom of the thermowell, the insert must be spring-loaded (spring travel: max. 10 mm).	
Spring travel	max. 10 mm	

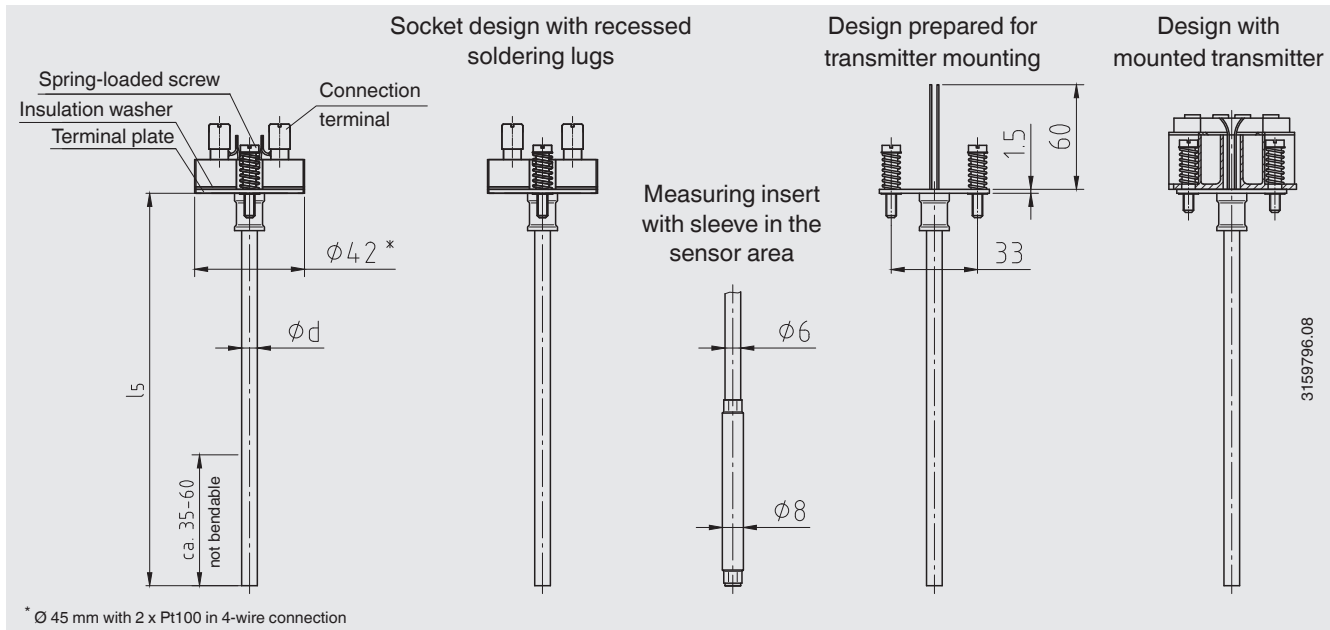



Measuring insert diameter ϕd in mm	Index per DIN 43735	Tolerance in mm	Sheath material	
			Standard design	Recessed soldering lugs
3	Standard	30	<ul style="list-style-type: none"> ■ 1.4571 ■ 316L 	1.4571
6	Standard	60		
8 (6 mm with sleeve)	Standard	-	<ul style="list-style-type: none"> ■ 1.4571 	1.4571
8	Standard	80	<ul style="list-style-type: none"> ■ 1.4571 ■ 316L 	1.4571

Legend:
 l_5 Measuring insert length
 ϕd Measuring insert diameter



Fig. left: Standard version
Fig. right: Version with recessed soldering lugs (option)

Transmitter

Transmitter models	Model T15	Model T32
Transmitter data sheet	TE 15.01	TE 32.04
Figure		
Output		
4 ... 20 mA	x	x
HART® protocol	-	x
Connection method	<ul style="list-style-type: none"> ■ 1 x 2-wire ■ 1 x 3-wire ■ 1 x 4-wire 	<ul style="list-style-type: none"> ■ 1 x 2-wire ■ 1 x 3-wire ■ 1 x 4-wire ■ 2 x 2-wire
Measuring current	< 0.2 mA	< 0.3 mA
Explosion protection	Option	Option
Mounting types		
Mounting onto the measuring insert	With mounting on the measuring insert, the transmitter replaces the terminal block and is fixed directly to the terminal plate of the measuring insert.	
Mounted within the cover of the connection head	Mounting the transmitter in the cover of the connection head is preferable to mounting it on the measuring insert. With this type of mounting, for one, a better thermal insulation is ensured, and in addition, exchange and mounting for servicing is simplified.	

Mounting types

Mounting onto the measuring insert



Measuring insert with mounted transmitter (here: Model T32)

Measuring insert prepared for transmitter mounting

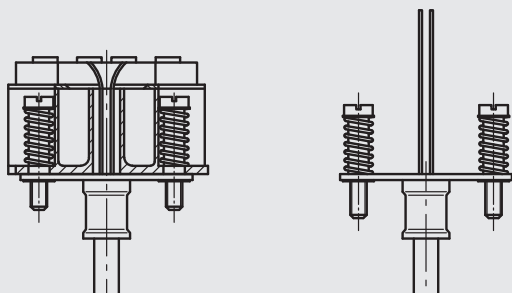

Mounted within the cover of the connection head



Possible mounting positions for transmitters	Model T15	Model T32
BS	○	-
BSZ	○	○
BSZ-H	●	●
BSZ-H (2 x cable outlet)	●	●
BSZ-H / DIH10	○	○
BSS	○	○
BSS-H	●	●
BVS	○	○
BSZ-K	○	○
BSZ-HK	●	●
KN4-A	○	○
KN4-P	○	○
1/4000	○	○
7/8000	○	○
7/8000 / DIH50	○	○

Legend:

- Mounted instead of terminal block
- Mounted within the cover of the connection head
- Mounting not possible

The mounting of a transmitter on the measuring insert is possible with all the connection heads listed here. The fitting of a transmitter in the (screw) cap of a North American design connection head is not possible.

Mounting of 2 transmitters on request.

For a correct determination of the overall measuring deviation, the sensor and transmitter measuring deviations must be added.

Functional safety with model T32 temperature transmitter (option)



In safety-critical applications, the entire measuring chain must be taken into consideration in terms of the safety parameters. The SIL classification allows the assessment of the risk reduction achieved by the safety installations.

Selected TR10-B resistance thermometers, in combination with a suitable temperature transmitter (e.g. model T32.1S, TÜV certified SIL version for protection systems developed in accordance with IEC 61508), are suitable as sensors for safety functions to SIL 2.

→ For detailed specifications, see Technical information IN 00.19 at www.wika.com.

Neck tube

Versions

Neck tube design	Diameter	Connection to head	Connection to thermowell	Material
Neck tube per DIN 43772	<ul style="list-style-type: none"> ■ 12 x 1.5 mm ■ 12 x 2.5 mm 	M24 x 1.5 (rotatable threaded connection)	<ul style="list-style-type: none"> ■ Mounting thread ■ Compression fitting ■ Union nut ■ Pressure screw ■ Without threaded connection, plain 	1.4571
	14 x 2.5 mm	M24 x 1.5 (rotatable threaded connection)	<ul style="list-style-type: none"> ■ Mounting thread ■ Union nut ■ Pressure screw 	1.4571
Neck tube with counter nut to head	14 x 2.5 mm	M20 x 1.5 (with counter nut)	Mounting thread	1.4571
Double threaded hex bushing (with hexagonal spanner flats)	-	M24 x 1.5, ½ NPT	Mounting thread	1.4571
“Nipple-union-nipple” neck tube	~ 22 mm	½ NPT	Mounting thread	316
	~ 27 mm	¾ NPT	Mounting thread	316
Double threaded hex bushing (tube section)	~ 22 mm	½ NPT	Mounting thread	316
	~ 27 mm	¾ NPT	Mounting thread	316

Thread sizes

Neck tube design	Diameter	Thread to the thermowell
Neck tube per DIN 43772	<ul style="list-style-type: none"> ■ 12 x 1.5 mm ■ 12 x 2.5 mm 	<ul style="list-style-type: none"> ■ G ½ B ■ G ¾ B ■ G ¼ B ■ M20 x 1.5 ■ M18 x 1.5 ■ M14 x 1.5 ■ ½ NPT ■ ¾ NPT ■ G ½ B compression fitting (metal ferrule) ■ G ¾ B compression fitting (metal ferrule) ■ M18 x 1.5 compression fitting (metal ferrule) ■ M20 x 1.5 compression fitting (metal ferrule) ■ G ½ B union nut ■ G ¾ B union nut ■ M20 x 1.5 union nut ■ G ½ B pressure screw ■ G ¾ B pressure screw ■ M20 x 1.5 pressure screw ■ Without threaded connection, plain
Neck tube per DIN 43772	14 x 2.5 mm	<ul style="list-style-type: none"> ■ G ½ B ■ G ¾ B ■ G ¼ B ■ M20 x 1.5 ■ M18 x 1.5 ■ M14 x 1.5 ■ ½ NPT ■ ¾ NPT ■ G ½ B union nut ■ G ¾ B union nut ■ M20 x 1.5 union nut ■ G ½ B pressure screw ■ G ¾ B pressure screw ■ M20 x 1.5 pressure screw

Neck tube design	Diameter	Thread to the thermowell
Neck tube with counter nut to head	14 x 2.5 mm	<ul style="list-style-type: none"> ■ 1/2 NPT ■ 3/4 NPT ■ G 1/2 B ■ G 3/4 B ■ G 1/4 B ■ M14 x 1.5 ■ M18 x 1.5 ■ M20 x 1.5
Double threaded hex bushing (with hexagonal spanner flats)	-	<ul style="list-style-type: none"> ■ G 1/2 B ■ G 3/4 B ■ G 1/4 B ■ 1/2 NPT ■ 3/4 NPT ■ M14 x 1.5 ■ M18 x 1.5 ■ M20 x 1.5
"Nipple-union-nipple" neck tube	~ 22 mm	1/2 NPT
	~ 27 mm	3/4 NPT
Double threaded hex bushing (tube section)	~ 22 mm	1/2 NPT
	~ 27 mm	3/4 NPT

Neck lengths

Neck tube design	Neck length	Min. / Max. neck length
Neck tube per DIN 43772	150 mm [approx. 6 in]	30 mm [approx. 1.2 in] / 500 mm [approx. 20 in]
Neck tube per DIN 43772, plain	150 mm [approx. 6 in]	75 mm [approx. 3 in] / 900 mm [approx. 35 in]
Neck tube with counter nut to head	150 mm [approx. 6 in]	75 mm [approx. 3 in] / 250 mm [approx. 10 in]
Double threaded hex bushing (with hexagonal spanner flats)		
M24 x 1.5 to connection head, parallel thread to thermowell	13 mm	-
1/2 NPT to connection head, parallel thread to thermowell	25 mm	-
M24 x 1.5 to connection head, tapered thread to thermowell	25 mm	-
1/2 NPT to connection head, tapered thread to thermowell	25 mm	-
"Nipple-union-nipple" neck tube	150 mm [approx. 6 in]	75 mm [approx. 3 in] / 250 mm [approx. 10 in]
Double threaded hex bushing (tube section)	50 mm [approx. 2 in]	50 mm [approx. 2 in] / 250 mm [approx. 10 in]

The neck tube is screwed into the connection head. The neck length depends on the intended use. Usually an isolation is bridged by the neck tube. Also, in many cases, the neck tube serves as a cooling extension between the connection head and the medium, in order to protect a possible built-in transmitter from high medium temperatures.

Other versions on request

Operating conditions

Operating conditions	
Ambient and storage temperature	-60 ¹⁾ / -40 ... +80 °C
Vibration resistance	The information on vibration resistance refers to the tip of the measuring insert. → For detailed specifications on the vibration resistance of Pt100 sensors, see Technical information IN 00.17 at www.wika.de .
Standard	6 g peak-to-peak, wire-wound measuring resistor or thin film
Option	<ul style="list-style-type: none"> ■ Vibration-resistant probe tip, max. 20 g peak-to-peak, thin-film measuring resistor ■ Highly vibration-resistant probe tip, max. 50 g peak-to-peak, thin-film measuring resistor

IP ingress protection per IEC/EN 60529

First index number	Degree of protection / Short description	Test parameters
Degrees of protection against solid foreign bodies (defined by the 1st index number)		
5	Dust-protected	Per IEC/EN 60529
6	Dust-tight	Per IEC/EN 60529
Degrees of protection against water (defined by the 2nd index number)		
4	Protected against splash water	Per IEC/EN 60529
5	Protected against water jets	Per IEC/EN 60529
6	Protected against strong water jets	Per IEC/EN 60529
7 ²⁾	Protected against the effects of temporary immersion in water	Per IEC/EN 60529
8 ²⁾	Protected against the effects of permanent immersion in water	As agreed upon

1) Special version on request (explosion-protected versions only available with specific approvals)







2) Ingress protections, describing temporary or permanent immersion, on request

Standard ingress protection of model TR10-B is IP65.

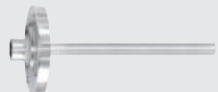
The specified degrees of protection apply under the following conditions:

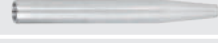
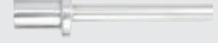
- Use of a suitable thermowell
(without suitable thermowell: IP40)
- Use of a suitable cable gland
- Use of a cable cross-section appropriate for the gland or select the appropriate cable gland for the available cable
- Adhere to the tightening torques for all threaded connections

Thermowell (option)

Thermowell selection		
Model	Data sheet	Illustration
TW10	<ul style="list-style-type: none"> ■ TW 95.10 ■ TW 95.11 ■ TW 95.12 	
TW15	TW 95.15	
TW20	TW 95.20	
TW25	TW 95.25	
TW30	TW 95.30	
TW45	TW 95.45	
TW50	TW 95.50	
TW55	TW 95.55	





Special thermowells on request









Approvals

Approvals included in the scope of delivery

Logo	Description	Country
	EU declaration of conformity	European Union
	EMC directive ¹⁾	
	EN 61326 emission (group 1, class B) and immunity (industrial application)	
	RoHS directive	

Optional approvals

Logo	Description	Country	
	EU declaration of conformity	European Union	
	ATEX directive		
	Hazardous areas		
	- Ex i Zone 0 gas		II 1G Ex ia IIC T1 ... T6 Ga
	Zone 1 mounting to zone 0 gas		II 1/2G Ex ia IIC T1 ... T6 Ga/Gb
	Zone 1 gas		II 2G Ex ia IIC T1 ... T6 Gb
	Zone 20 dust		II 1D Ex ia IIIC T125 ... T65 °C Da
	Zone 21 mounting to zone 20 dust		II 1/2D Ex ia IIIC T125 ... T65 °C Da/Db
	Zone 21 dust		II 2D Ex ia IIIC T125 ... T65 °C Db
	- Ex e ²⁾ Zone 1 gas		II 2G Ex eb IIC T1 ... T6 Gb ⁴⁾
	Zone 2 gas		II 3G Ex ec IIC T1 ... T6 Gc X
	Zone 21 dust		II 2D Ex tb IIIC TX °C Db ⁴⁾
Zone 22 dust	II 3D Ex tc IIIC TX °C Dc X		
- Ex n ²⁾ Zone 2 gas	II 3G Ex nA IIC T1 ... T6 Gc X		
Zone 22 dust	II 3D Ex tc IIIC TX °C Dc X		
	IECEx - in combination with ATEX	International	
	Hazardous areas		
	- Ex i Zone 0 gas		Ex ia IIC T1 ... T6 Ga
	Zone 1 mounting to zone 0 gas		Ex ia IIC T1 ... T6 Ga/Gb
	Zone 1 gas		Ex ia IIC T1 ... T6 Gb
	Zone 20 dust		Ex ia IIIC T125 ... T65 °C Da
	Zone 21 mounting to zone 20 dust		Ex ia IIIC T125 ... T65 °C Da/Db
	Zone 21 dust		Ex ia IIIC T125 ... T65 °C Db
	- Ex e ³⁾ Zone 1 gas		Ex eb IIC T1 ... T6 Gb ⁴⁾
	Zone 2 gas		Ex ec IIC T1 ... T6 Gc
	Zone 21 dust		Ex tb IIIC TX °C Db ⁴⁾
	Zone 22 dust		Ex tc IIIC TX °C Dc
- Ex n ³⁾ Zone 2 gas	Ex nA IIC T1 ... T6 Gc		
Zone 22 dust	Ex tc IIIC TX °C Dc		
	EAC	Eurasian Economic Community	
	Hazardous areas		
	- Ex i Zone 0 gas		0 Ex ia IIC T6 ... T1 Ga X
	Zone 1 gas		1 Ex ia IIC T6 ... T1 Gb X
	Zone 20 dust		Ex ia IIIC T80...T440 °C Da X
Zone 21 dust	Ex ia IIIC T80...T440 °C Db X		
- Ex n Zone 2 gas	2Ex nA IIC T6 ... T1 Gc X		
	Ex Ukraine	Ukraine	
	Hazardous areas		
	- Ex i Zone 0 gas		II 1G Ex ia IIC T1 ... T6 Ga
	Zone 1 mounting to zone 0 gas		II 1/2G Ex ia IIC T1 ... T6 Ga/Gb
	Zone 1 gas		II 2G Ex ia IIC T1 ... T6 Gb
	Zone 20 dust		II 1D Ex ia IIIC T65°C Da
Zone 21 mounting to zone 20 dust	II 1/2D Ex ia IIIC T65°C Da/Db		
Zone 21 dust	II 2D Ex ia IIIC T65°C Db		
	INMETRO	Brazil	
	Hazardous areas		
	- Ex i Zone 0 gas		Ex ia IIC T3 ... T6 Ga
	Zone 1 mounting to zone 0 gas		Ex ia IIC T3 ... T6 Ga/Gb
	Zone 20 dust		Ex ia IIIC T125 ... T65 °C Da
Zone 21 mounting to zone 20 dust	Ex ia IIIC T125 ... T65 °C Da/Db		

Logo	Description	Country
	CCC Hazardous areas - Ex i Zone 0 gas Ex ia IIC T1 ~ T6 Ga Zone 1 gas Ex ia IIC T1 ~ T6 Gb Zone 1 mounting to zone 0 gas Ex ia IIC T1 ~ T6 Ga/Gb Zone 2 gas Ex ic IIC T1 ~ T6 Gc Zone 20 dust Ex iaD 20 T65/T95/T125°C Zone 21 dust Ex iaD 21 T65/T95/T125°C Zone 21 mounting to zone 20 dust Ex iaD 20/21 T65/T95/T125°C - Ex e Zone 1 gas Ex eb IIC T1 ~ T6 Gb ⁴⁾ Zone 2 gas Ex ec IIC T1 ~ T6 Gc - Ex n Zone 2 gas Ex nA IIC T1 ~ T6 Gc	China
	KCs - KOSHA Hazardous areas - Ex i Zone 0 gas Ex ia IIC T4 ... T6 Zone 1 gas Ex ib IIC T4 ... T6	South Korea
-	PESO Hazardous areas - Ex i Zone 0 gas Ex ia IIC T1 ... T6 Ga Zone 1 mounting to zone 0 gas Ex ia IIC T1 ... T6 Ga/Gb Zone 1 gas Ex ia IIC T1 ... T6 Gb	India
	GOST Metrology, measurement technology	Russia
	KazInMetr Metrology, measurement technology	Kazakhstan
-	MTSCHS Permission for commissioning	Kazakhstan
	BelGIM Metrology, measurement technology	Belarus
	UkrSEPRO Metrology, measurement technology	Ukraine
	Uzstandard Metrology, measurement technology	Uzbekistan
	DNV GL Type approval for the shipbuilding industry - Maximum insertion length l_1 : 435 mm - Connection head: Model BSZ - Neck tube: \varnothing 11 x 2 mm or \varnothing 12 x 2.5 mm, max. 150 mm long - Measuring insert: \varnothing 6 mm - Optional with TW10-P (data sheets TW 95.10, TW 95.12) <i>Location classification:</i> Temperature D (ambient temperature: -25 ... +70 °C) Humidity B (relative humidity: up to 100 %) Vibration B (frequency: 3 ... 25 Hz; amplitude: 1.6 mm peak; frequency: 25 ... 100 Hz; amplitude: 4 g) EMC Not relevant Case Required protection according to DNV rules shall be provided upon installation on board. For use on open deck a connection head IP68 is required. ⁴⁾ (for "open deck")	International

- 1) Only for built-in transmitter
- 2) Only with connection head, model BSZ, BSZ-H, 1/4000, 5/6000 or 7/8000 (see "Connection head")
- 3) Only with connection head, model 1/4000, 5/6000 or 7/8000 (see "Connection head")
- 4) Without transmitter
- 5) Suitable cable gland required



Instruments marked with "ia" may also be used in areas only requiring instruments marked with "ib" or "ic". If an instrument with "ia" marking has been used in an area with requirements in accordance with "ib" or "ic", it can no longer be operated in areas with requirements in accordance with "ia" afterwards.

Explosion protection (option)

The permissible power, P_{max} , as well as the permissible ambient temperature, for the respective category can be seen on the certificate for hazardous areas or in the operating instructions.

Transmitters have own certificates for hazardous areas. The permissible ambient temperature ranges of the built-in transmitters can be taken from the corresponding transmitter operating instructions and approvals.

Manufacturer's information and certificates

Logo	Description
	SIL 2 Functional safety
	NAMUR NE 024 Hazardous areas (Ex i)

Certificates (option)

Certification type	Measurement accuracy	Material certificate ¹⁾
2.2 test report	x	x
3.1 inspection certificate	x	x
DKD/DAkkS calibration certificate	x	-

1) Thermowells have their own material certificates for selected components

For calibration, the measuring insert is removed from the thermometer. The minimum length (metal part of the probe) for carrying out a measurement accuracy test 3.1 or DKD/DAkkS is 100 mm. Calibration of shorter lengths on request.

The different certifications can be combined with each other.

→ Approvals and certificates, see website

Dimensions

Neck tube per DIN 43772

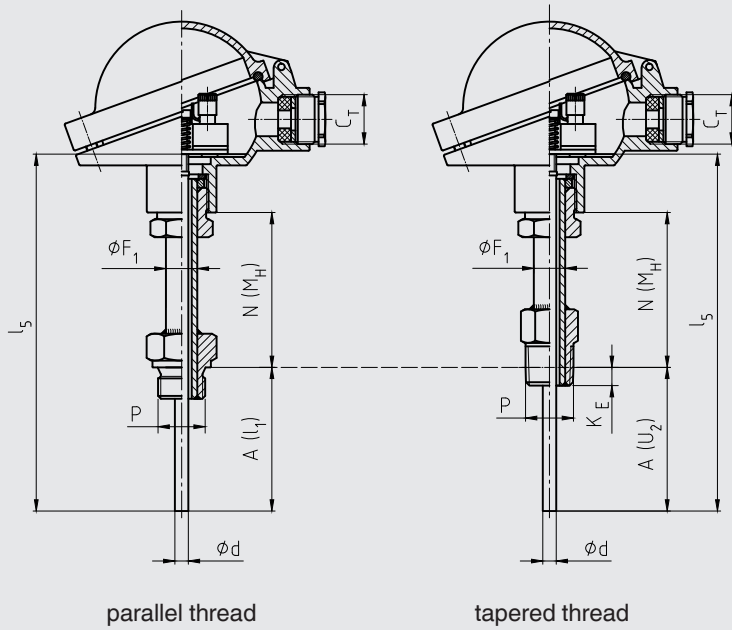

3160670.07

Neck tube per DIN 43772, plain, with/without compression fitting

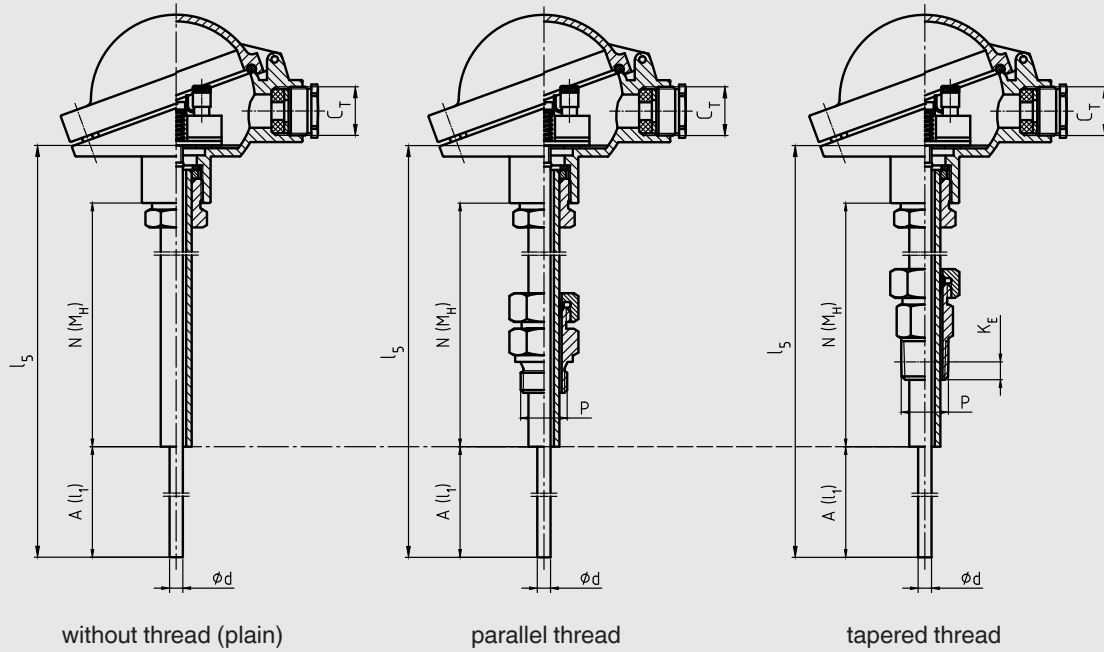

3160688.06

Legend:

- | | | | |
|---------------------|-------------------------------------|------------------|---------------------------|
| A (I ₁) | Insertion length (parallel threads) | C _T | Thread cable entry |
| A (U ₂) | Insertion length (tapered threads) | Ø F ₁ | Neck tube diameter |
| l ₅ | Measuring insert length | P | Thread to the thermowell |
| N (M _H) | Neck length | Ø d | Measuring insert diameter |
| K _E | 1/2 NPT: 8.13 mm | | |
| | 3/4 NPT: 8.61 mm | | |

The figures show examples of connection heads.

Neck tube, with counter nut to head

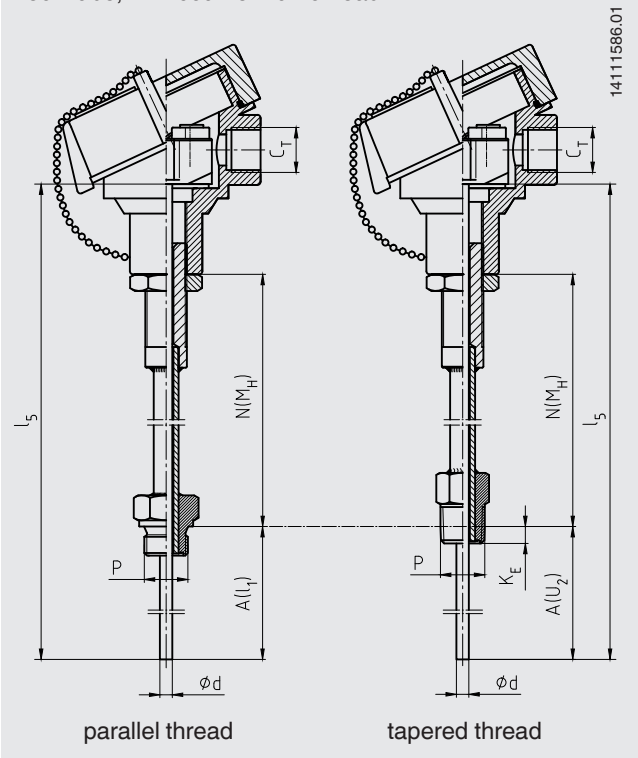

Double threaded hex bushing (with hexagonal spanner flats)

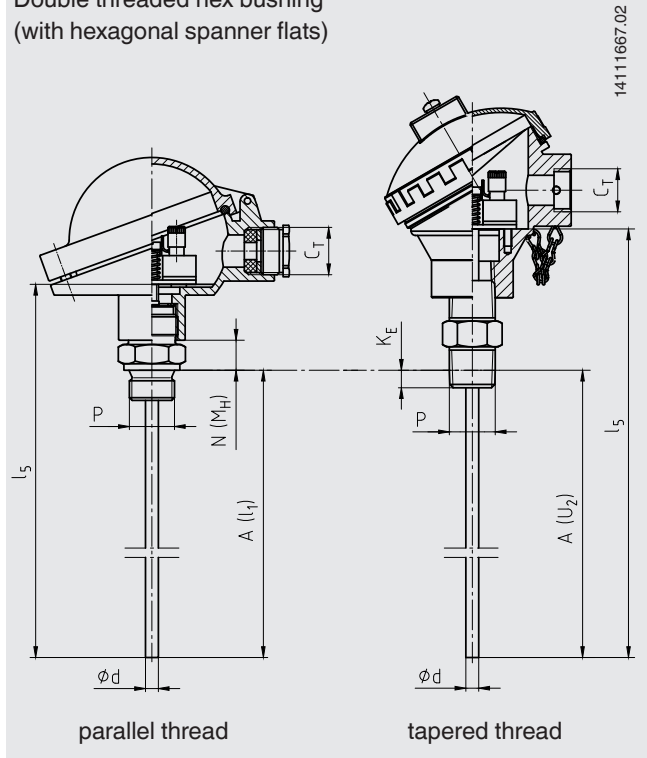

"Nipple-union-nipple" neck tube

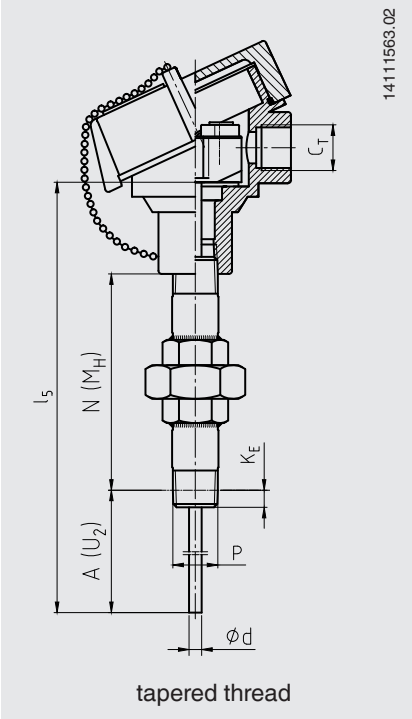

Double threaded hex bushing (tube section)

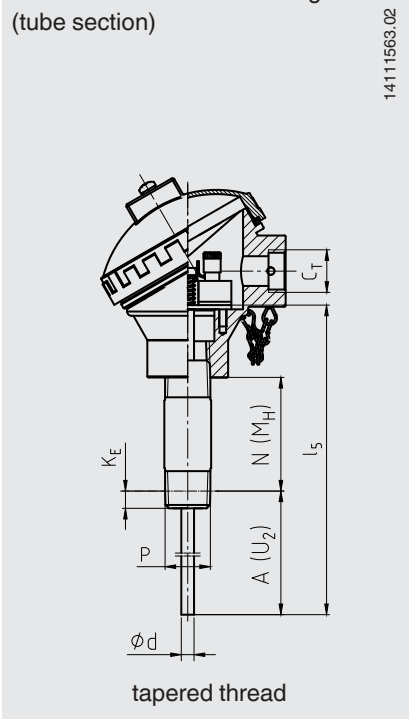

Without neck tube

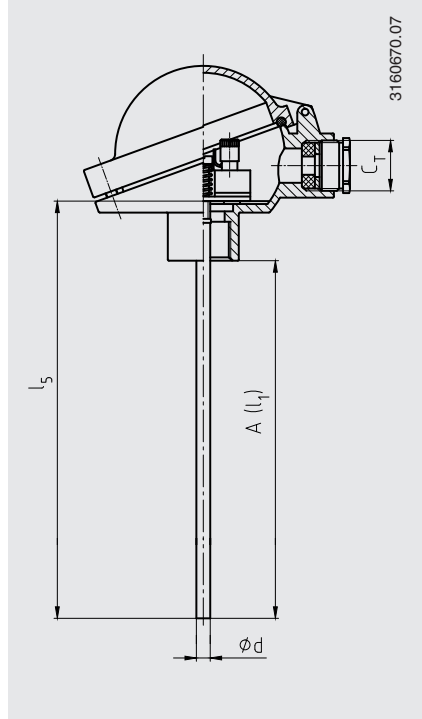

Legend:

- | | |
|--|------------------------------------|
| $A(l_1)$ Insertion length (parallel threads) | C_T Thread cable entry |
| $A(U_2)$ Insertion length (tapered threads) | ϕF_1 Neck tube diameter |
| l_5 Measuring insert length | P Thread to the thermowell |
| $N(M_H)$ Neck length | ϕd Measuring insert diameter |
| K_E 1/2 NPT: 8.13 mm | |
| 3/4 NPT: 8.61 mm | |

The figures show examples of connection heads.

